

SUPER PROFILE

WINDOW SECTIONS

20514

0.715 kg/m

20526

0.425 kg/m

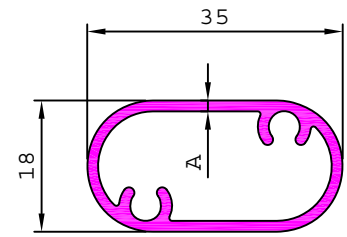
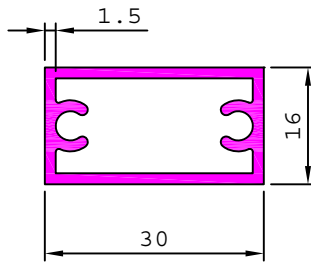
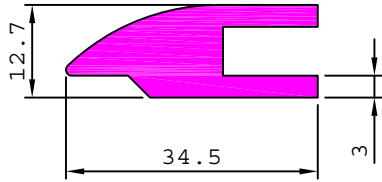

SL. No.	Section No.	A	Weight kg/m
1	20783	1.10	0.337
2	20527	1.50	0.408

20537

1.423 kg/m

20538

1.530 kg/m

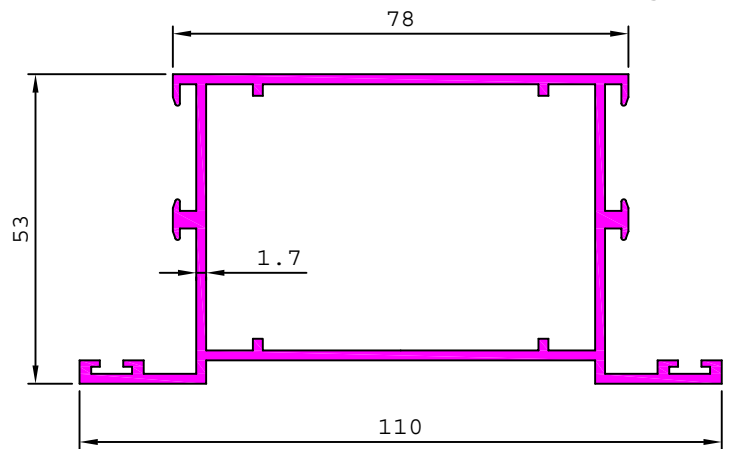
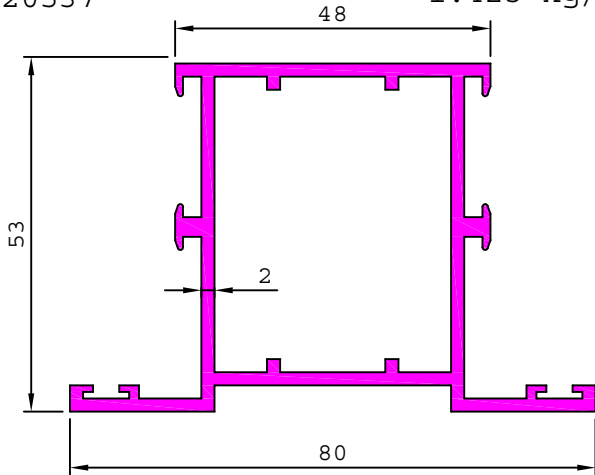

20539

1.313 kg/m

20540

0.521 kg/m

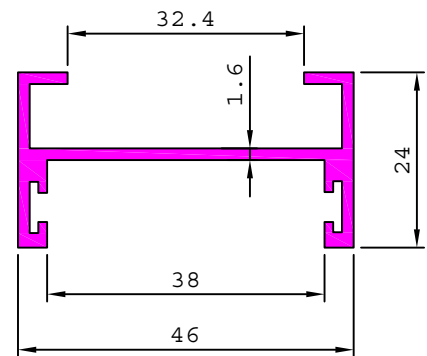
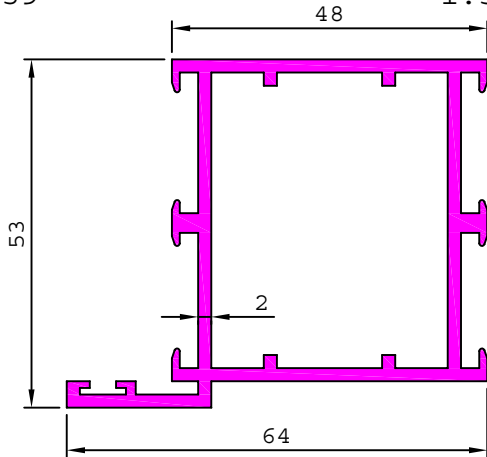

20548

1.268 kg/m

20554

0.969 kg/m

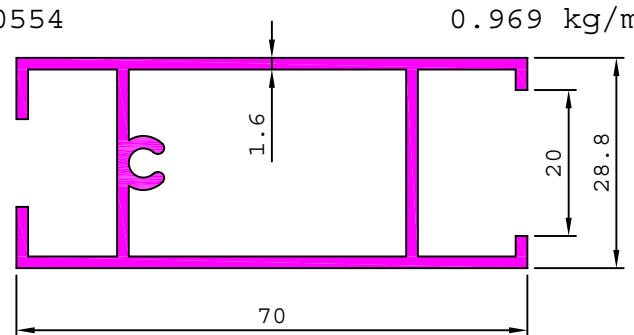
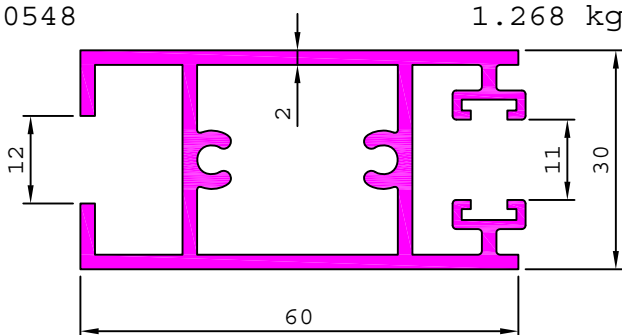

SUPER PROFILE

WINDOW SECTIONS

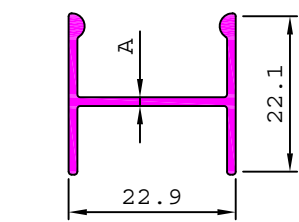
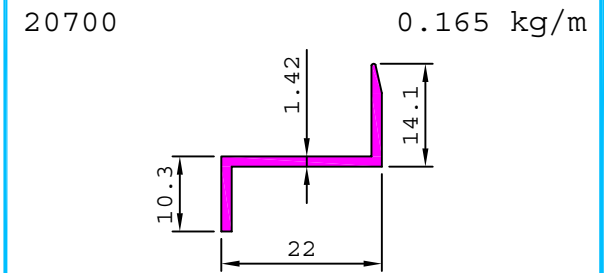
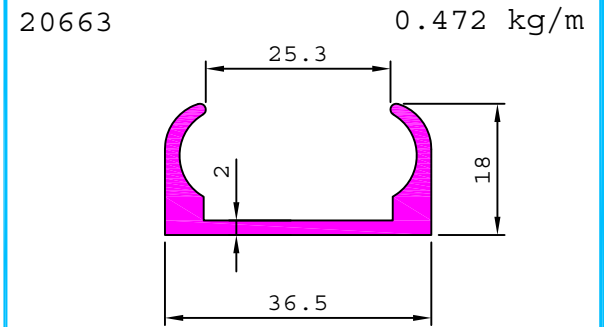
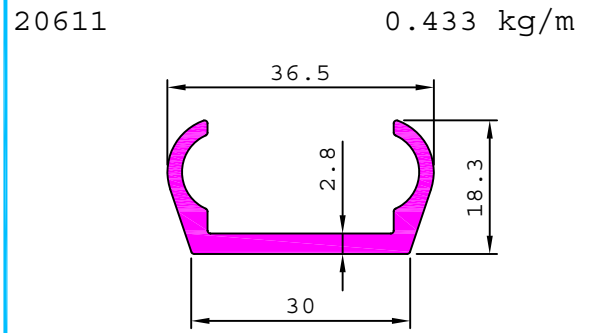
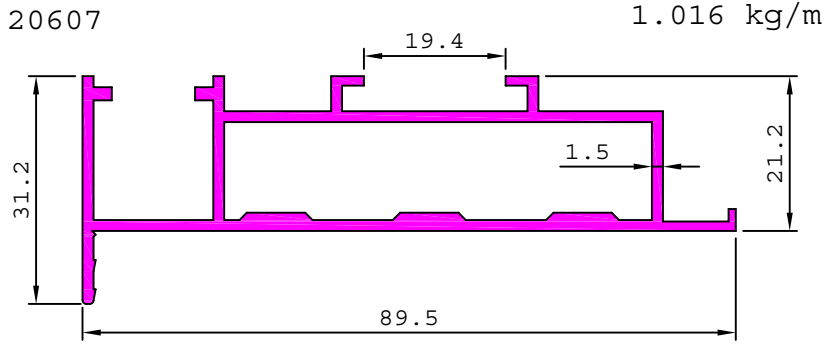

SL. No.	Section No.	A	Weight kg/m
1	20871	0.60	0.109
2	20822	0.69	0.137
3	20962	0.88	0.173
4	20784	1.00	0.191
5	20637	1.20	0.222

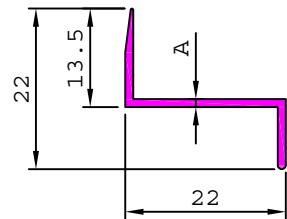

SL. No.	Section No.	A	Weight kg/m
1	21120	0.78	0.088
2	20693	1.10	0.124

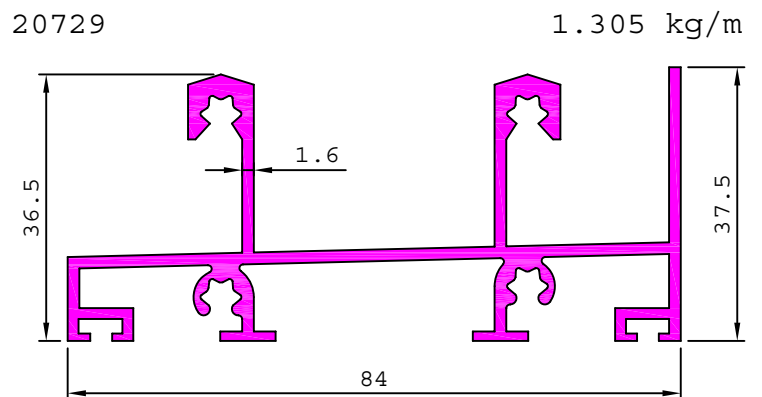
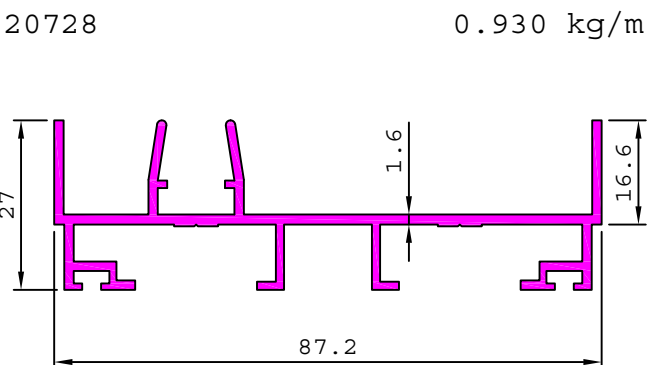
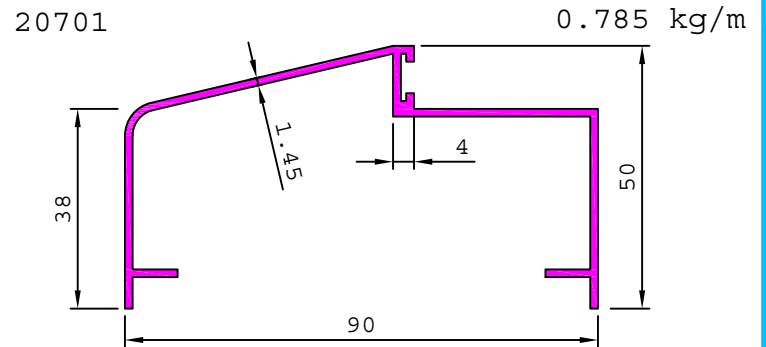
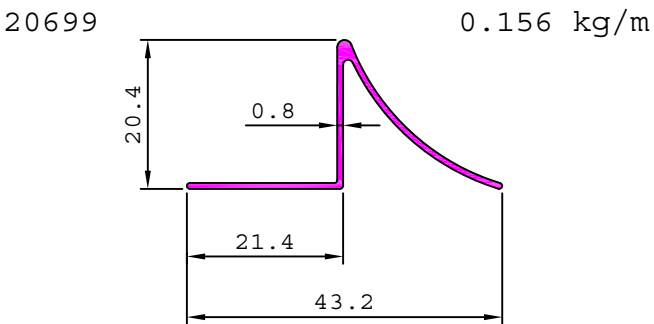

WINDOW SECTIONS

20742

1.088 kg/m

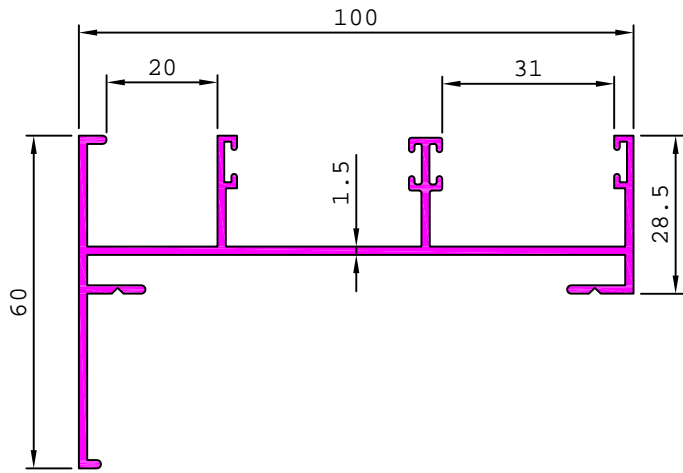

20743

1.088 kg/m

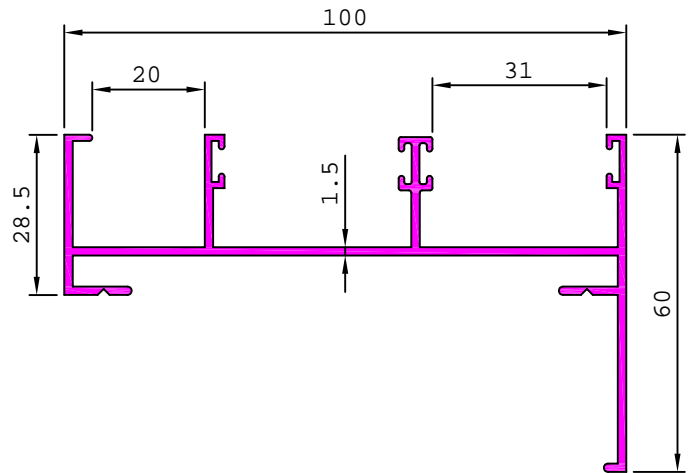

20744

1.476 kg/m

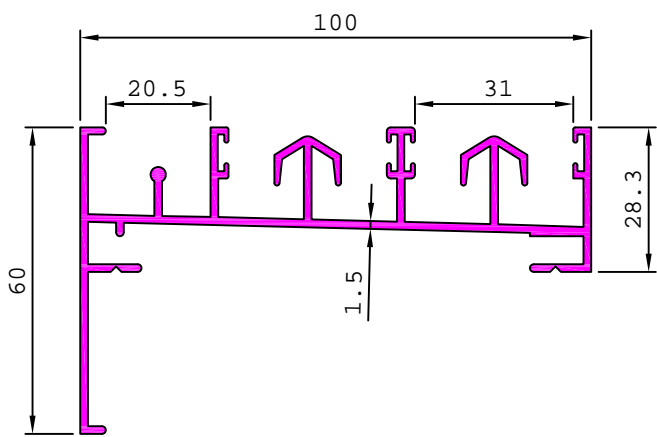

20745

0.578 kg/m

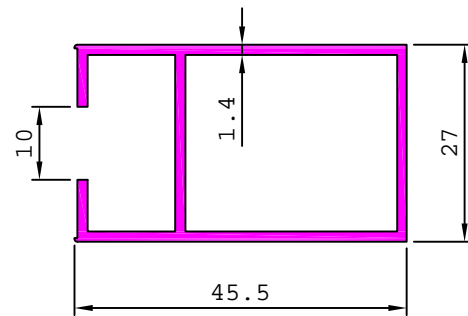

20748

0.660 kg/m

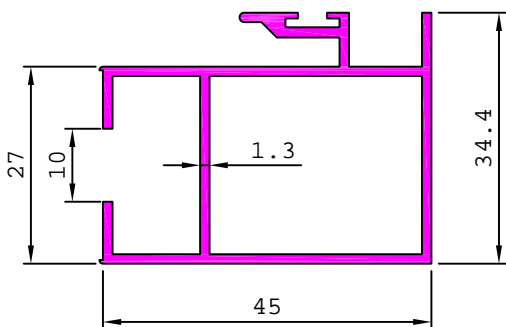

20749

0.867 kg/m

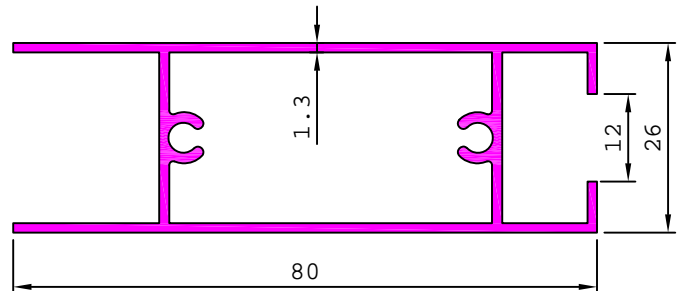

WINDOW SECTIONS

20756

1.235 kg/m

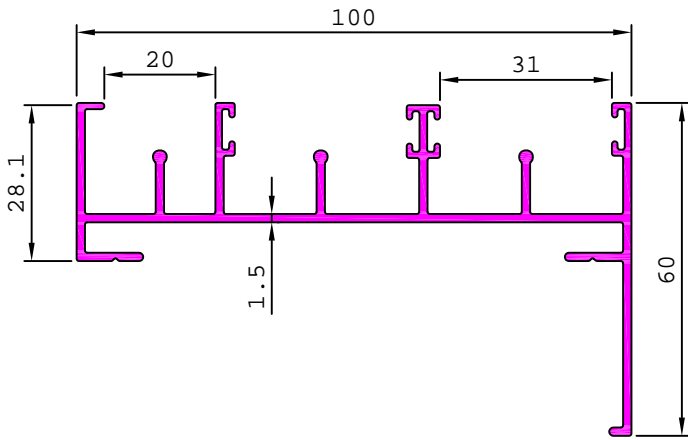

20775

1.750 kg/m

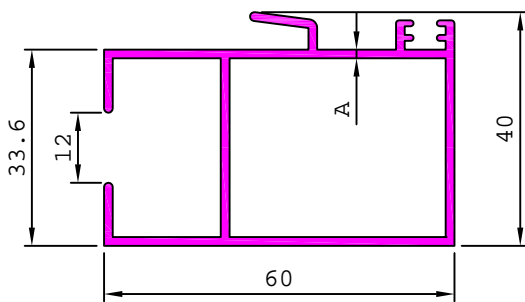
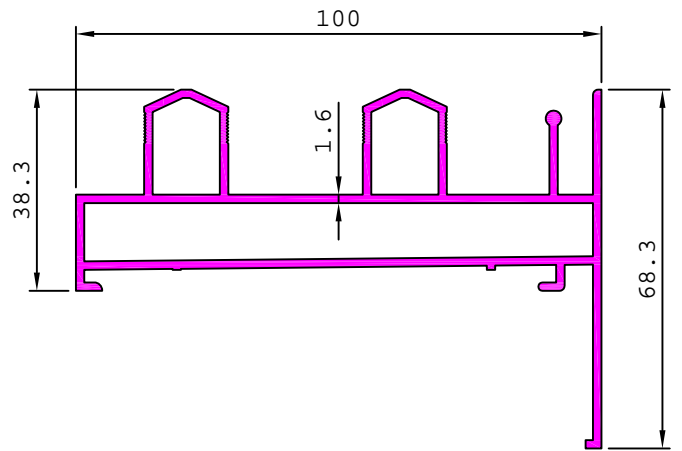

SL. No.	Section No.	A	Weight kg/m
1	20992	1.32	0.813
2	20773	1.50	0.923

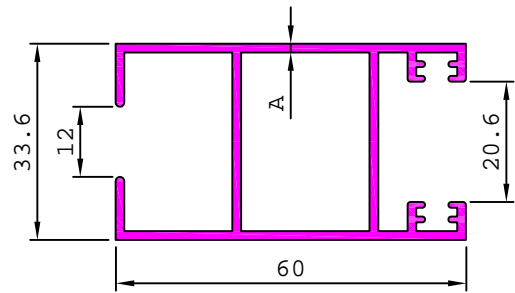

SL. No.	Section No.	A	Weight kg/m
1	20982	1.30	0.798
2	20774	1.50	0.918

20779

1.195 kg/m

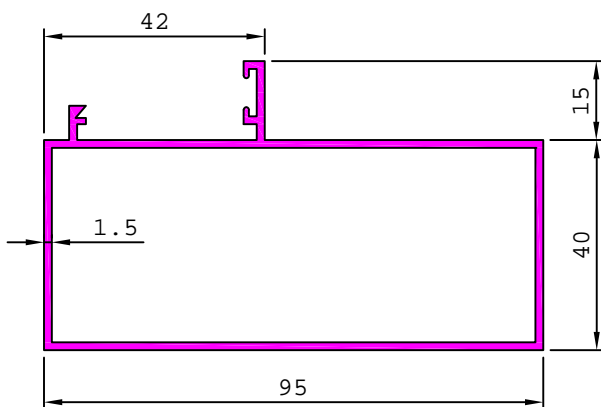

20780

0.557 kg/m

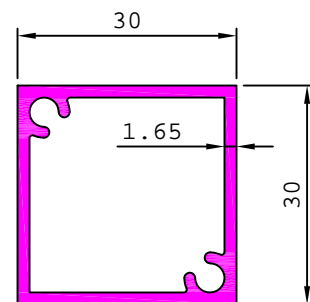

SUPER PROFILE

WINDOW SECTIONS

20786

0.788 kg/m

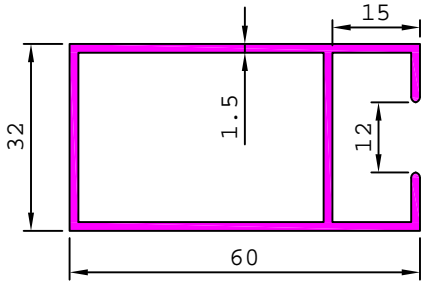

20788

1.005 kg/m

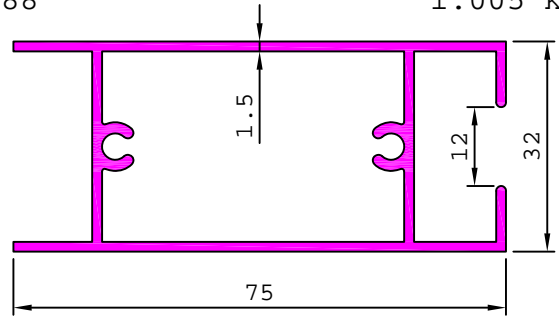

20785

0.952 kg/m

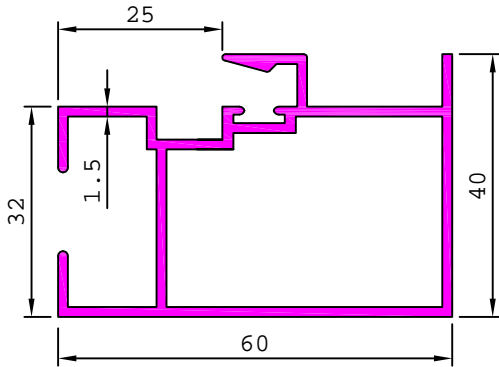

20792

1.488 kg/m

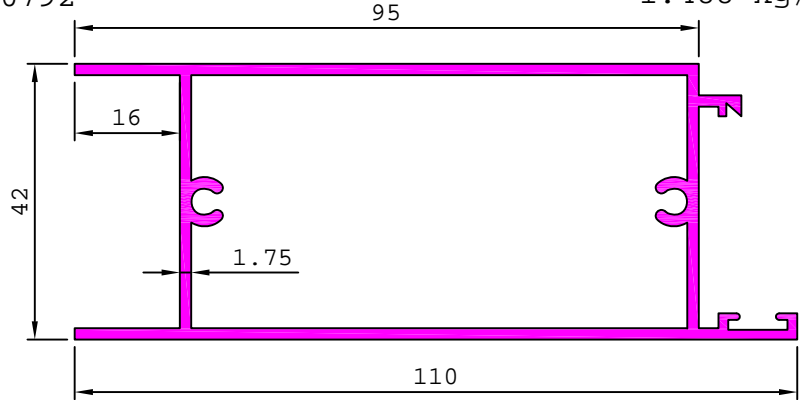

20793

1.220 kg/m

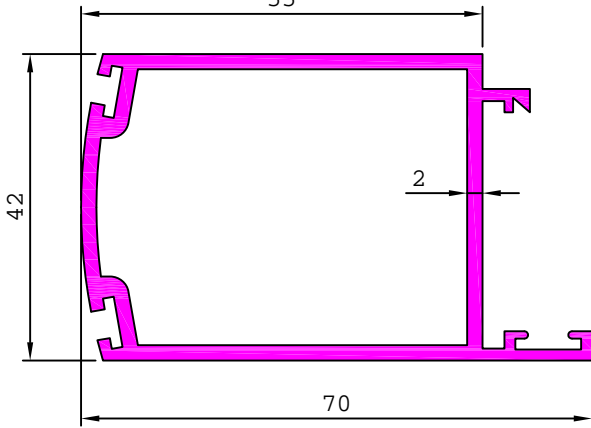

20795

1.233 kg/m

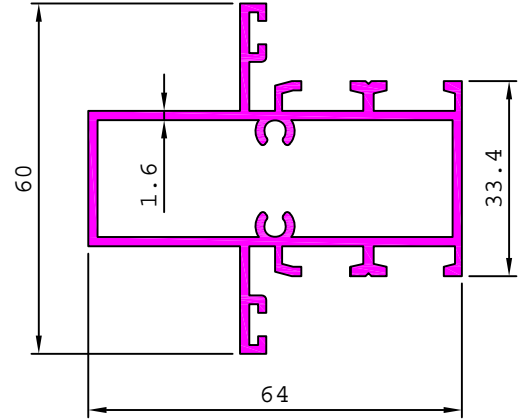

20794

1.394 kg/m

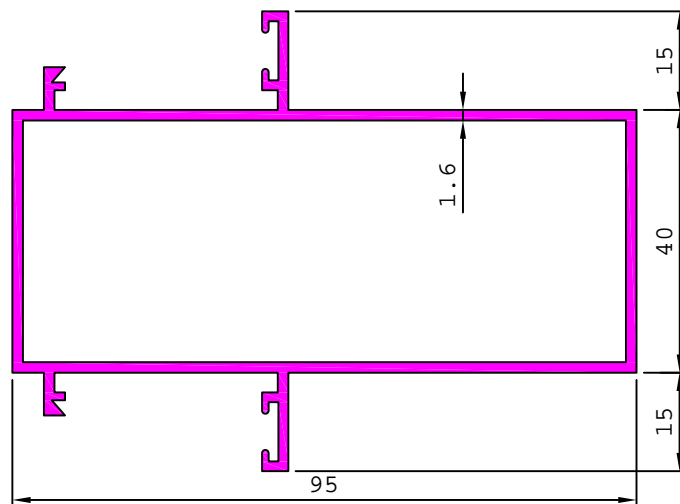

SUPER PROFILE

WINDOW SECTIONS

20819

1.383 kg/m

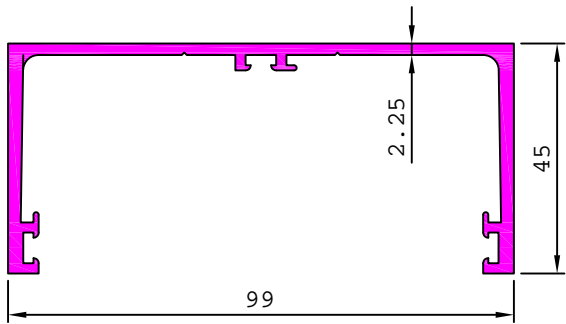

20821

1.747 kg/m

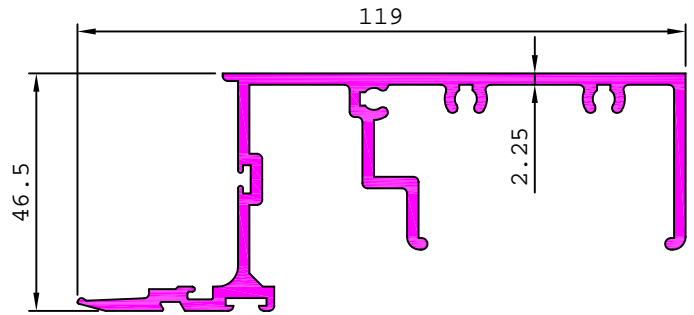

20820

2.397 kg/m

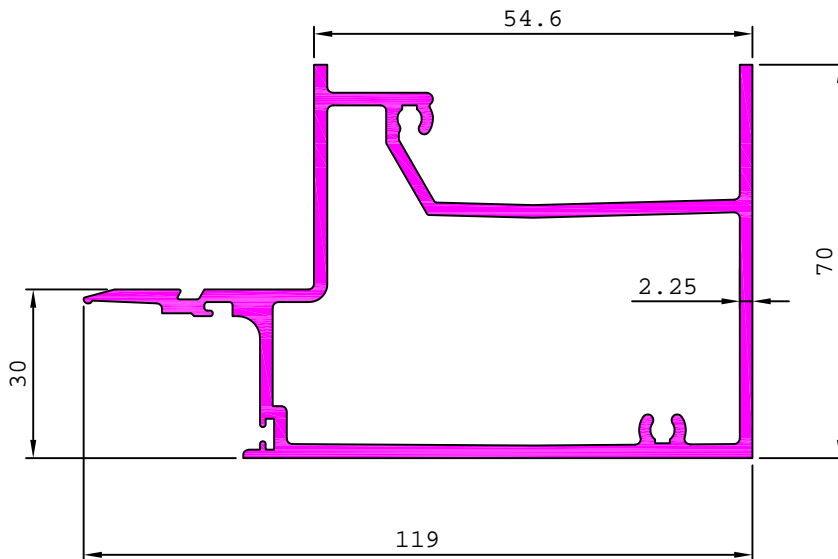

20854

0.923 kg/m

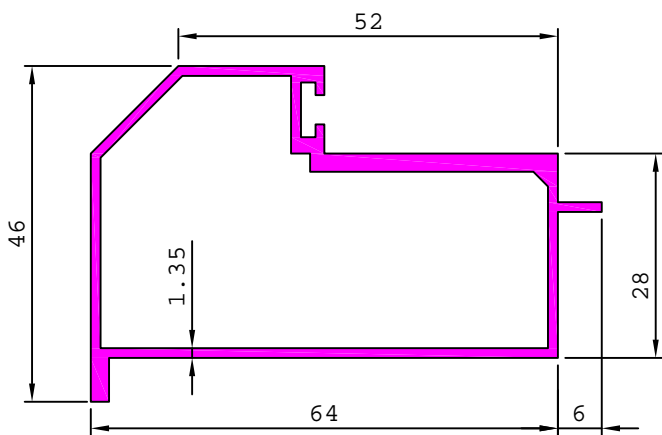

20861

0.858 kg/m

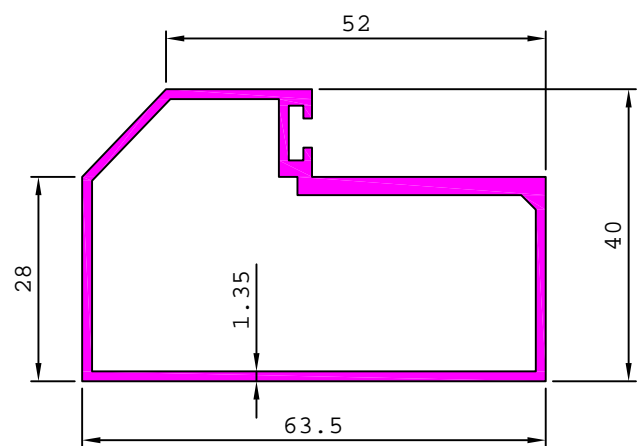

SUPER PROFILE

WINDOW SECTIONS

20867

0.810 kg/m

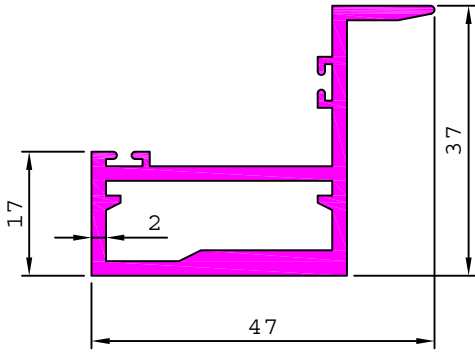

20881

0.748 kg/m

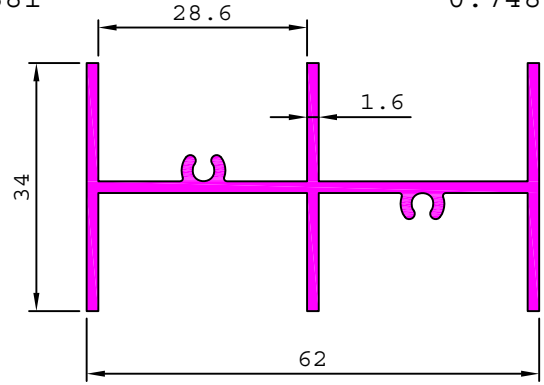

20879

0.904 kg/m

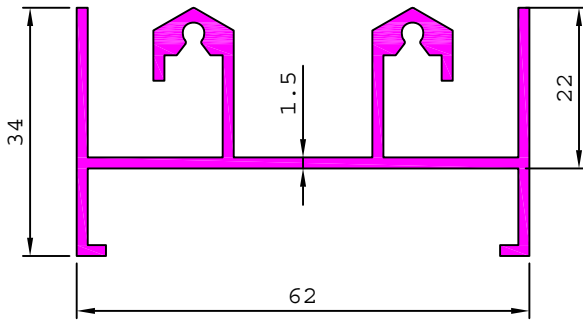

20880

1.218 kg/m

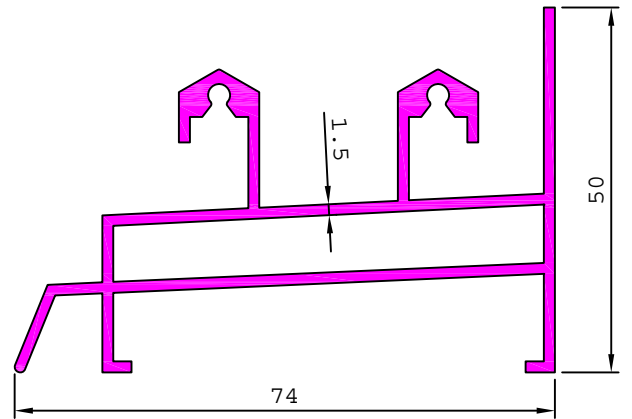

20890

0.657 kg/m

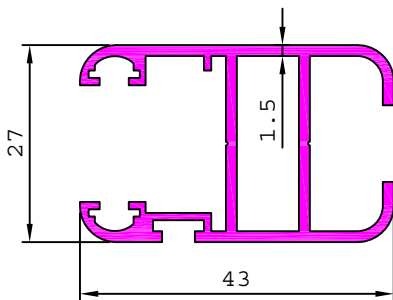

20894

0.588 kg/m

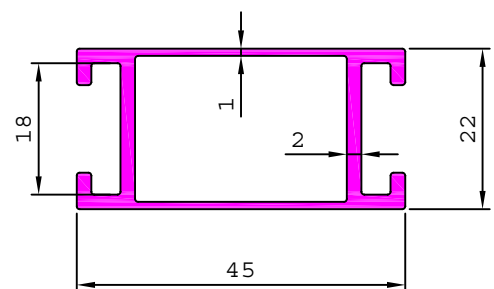

20891

0.688 kg/m

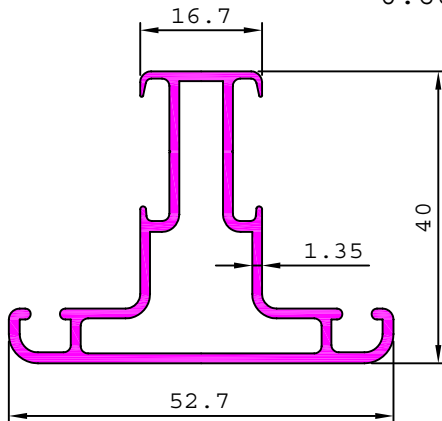

20901

0.827 kg/m

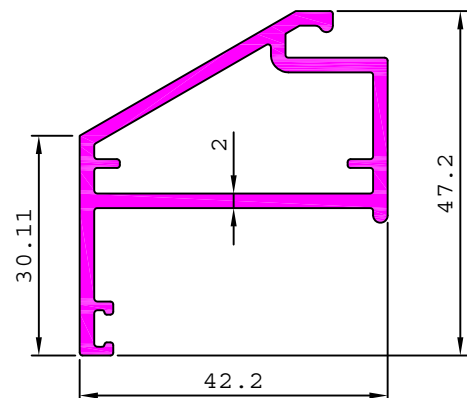

SUPER PROFILE

WINDOW SECTIONS

20917

0.656 kg/m

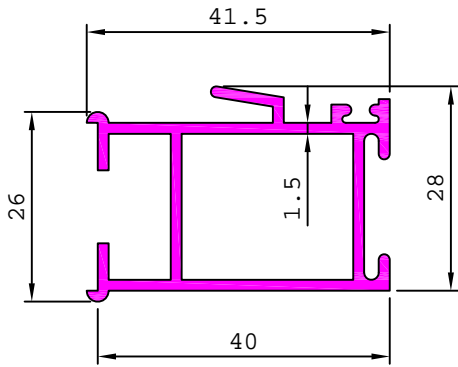

20929

1.073 kg/m

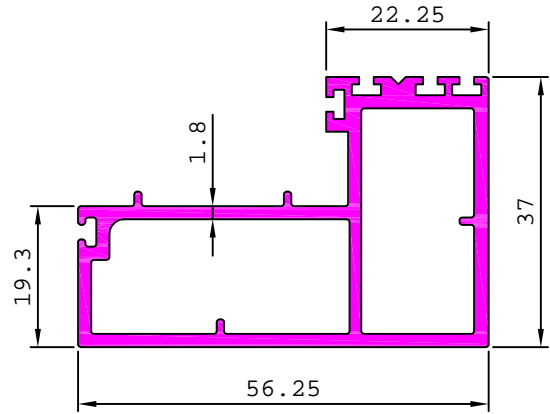

20932

0.758 kg/m

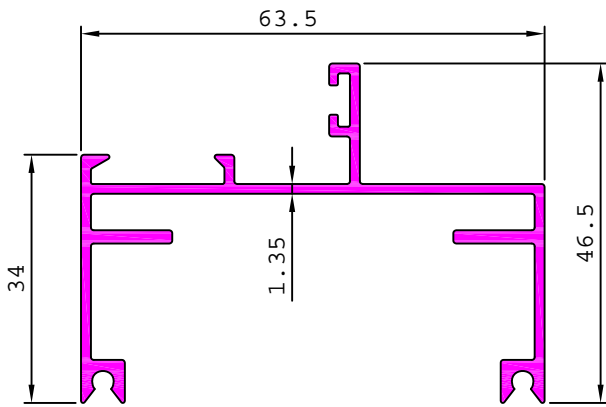

20933

1.304 kg/m

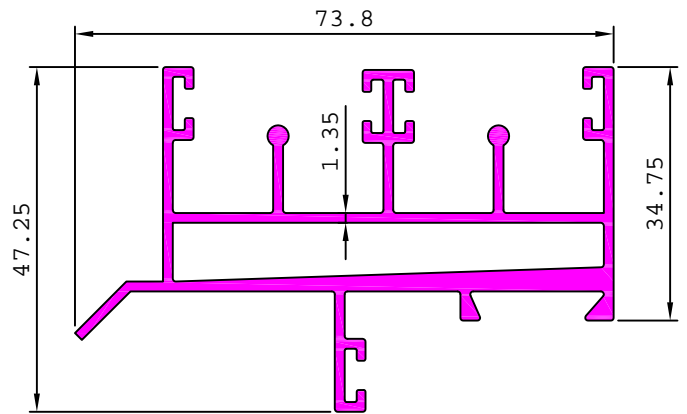

20934

1.093 kg/m

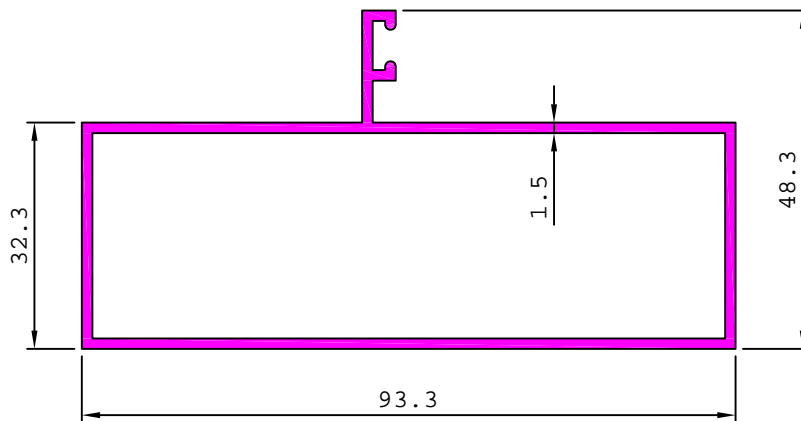

SUPER PROFILE

WINDOW SECTIONS

20980

1.649 kg/m

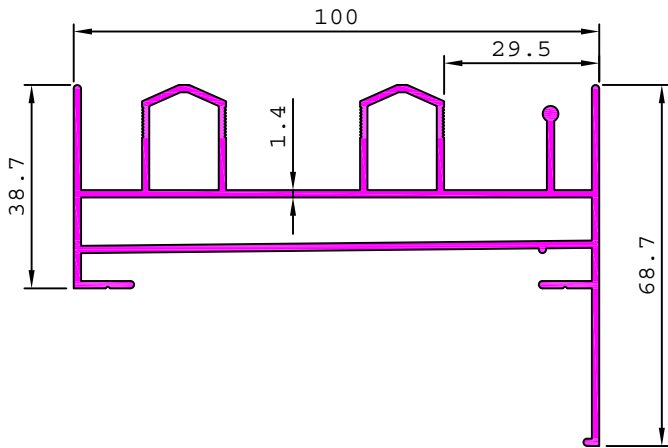

20981

1.167 kg/m

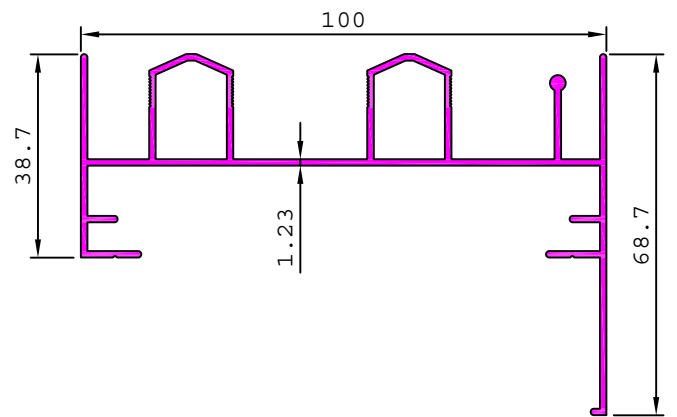

20971

0.885 kg/m

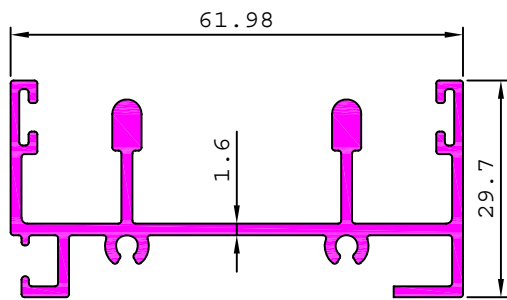

20996

2.102 kg/m

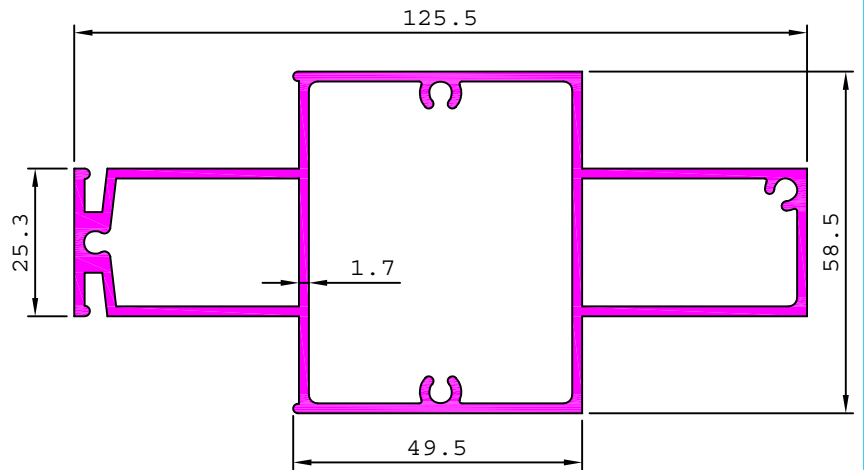

21003

0.875 kg/m

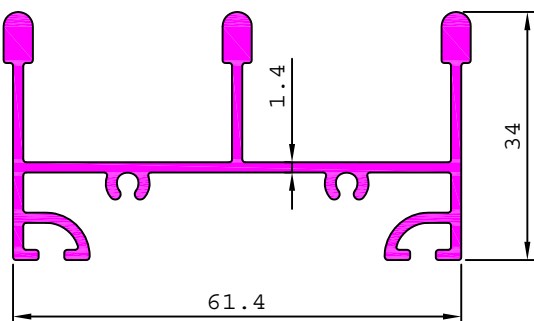

21004

0.848 kg/m

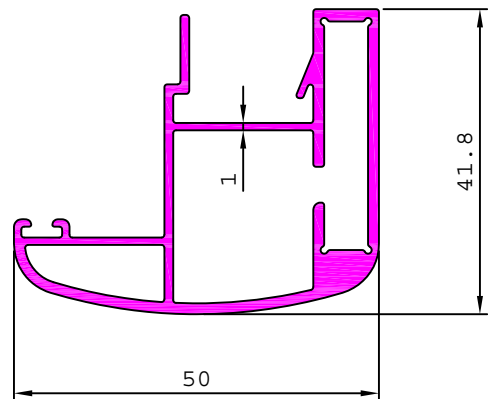

SUPER PROFILE

WINDOW SECTIONS

21005

1.023 kg/m

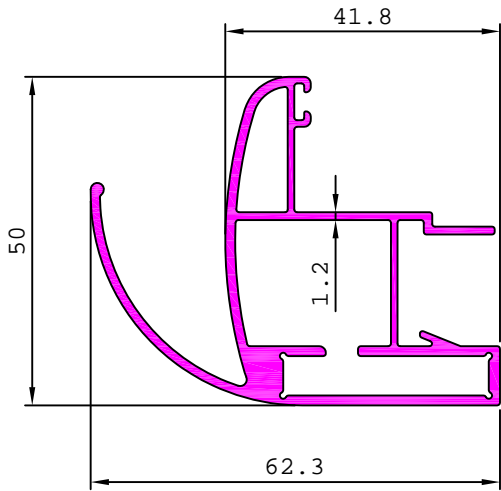

21006

1.193 kg/m

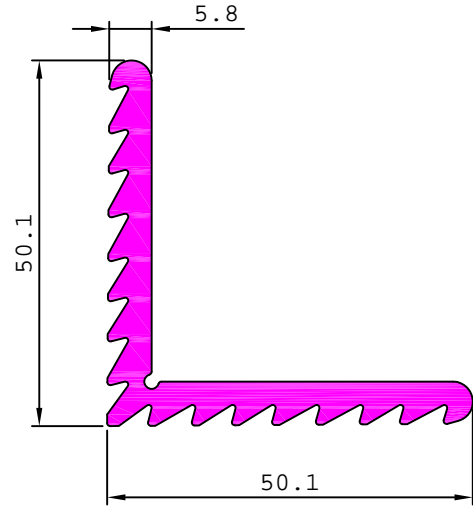

21007

0.994 kg/m

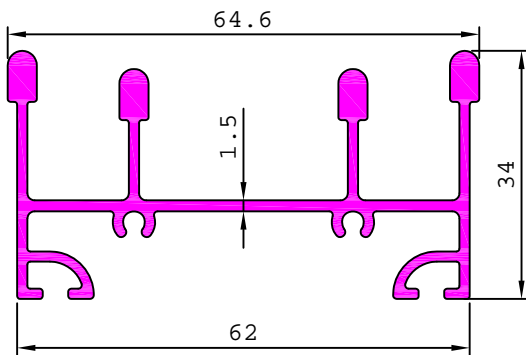

21036

0.588 kg/m

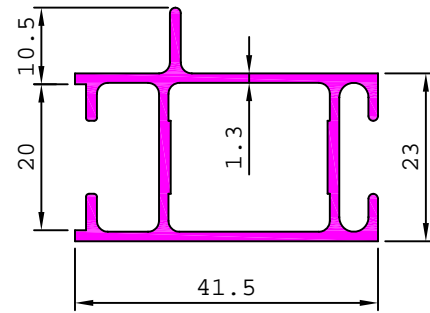

21012

0.751 kg/m

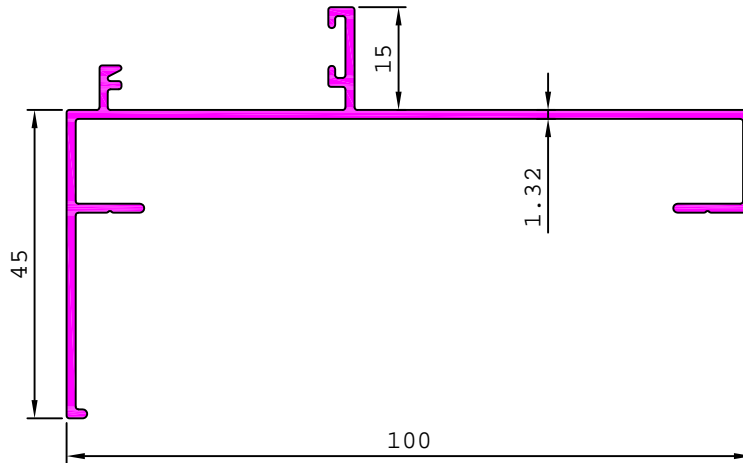

SUPER PROFILE

WINDOW SECTIONS

21013

1.137 kg/m

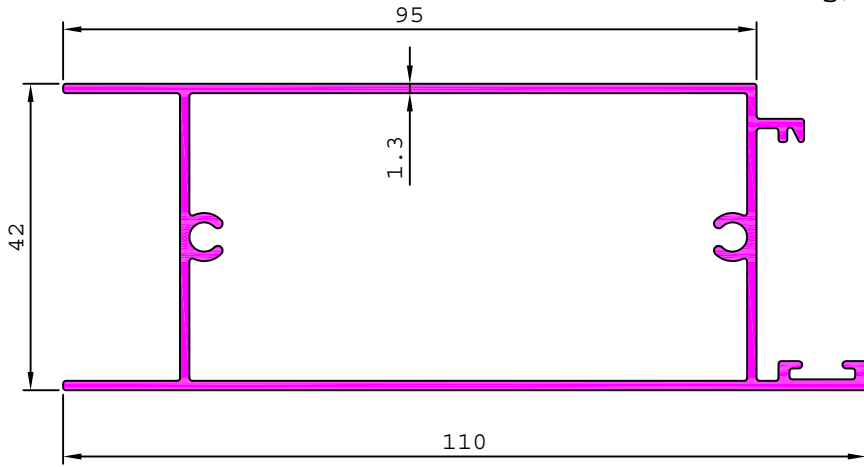

21037

0.594 kg/m

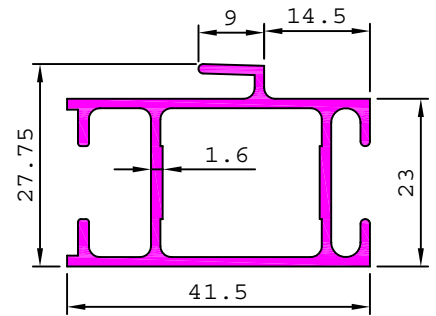

21024

2.702 kg/m

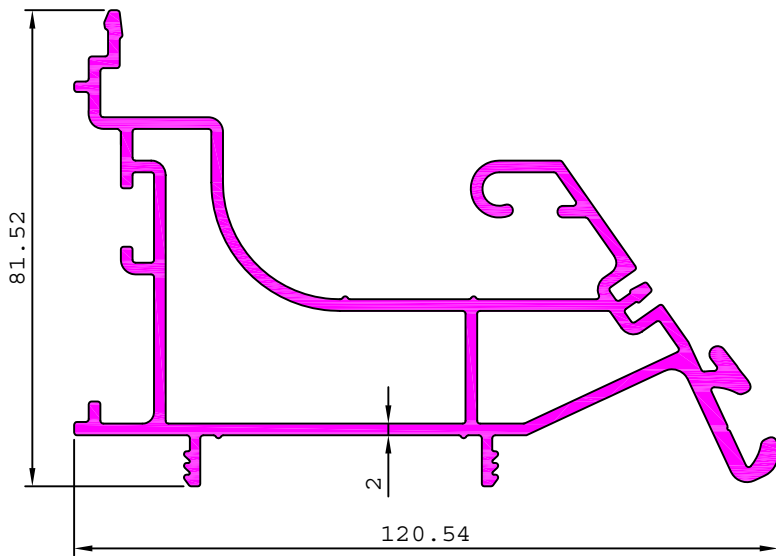

21040

0.691 kg/m

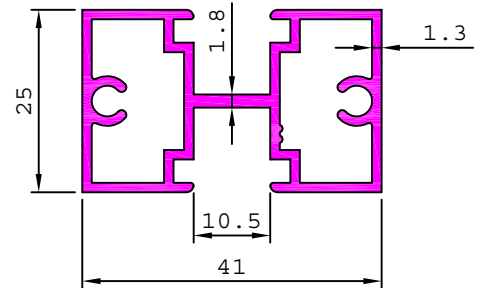

21042

0.718 kg/m

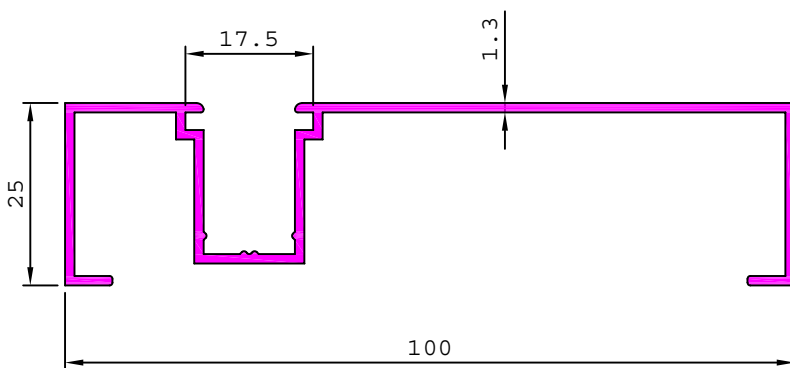

21048

0.591 kg/m

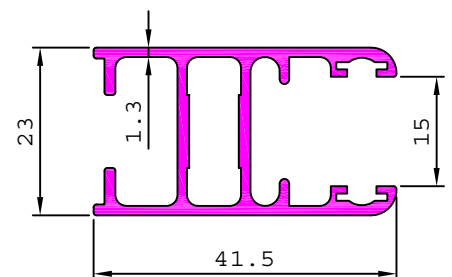

SUPER PROFILE

WINDOW SECTIONS

21043

0.886 kg/m

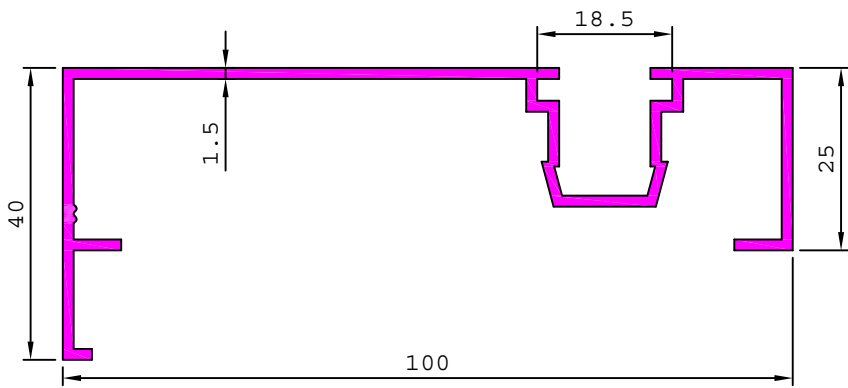

21058

0.786 kg/m

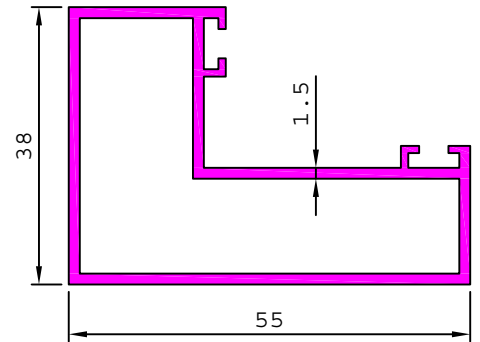

21047

0.940 kg/m

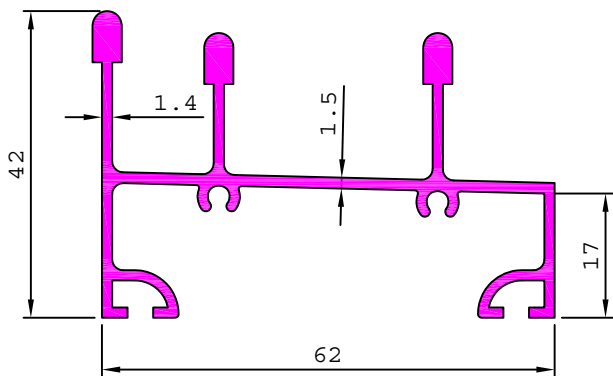

21049

0.977 kg/m

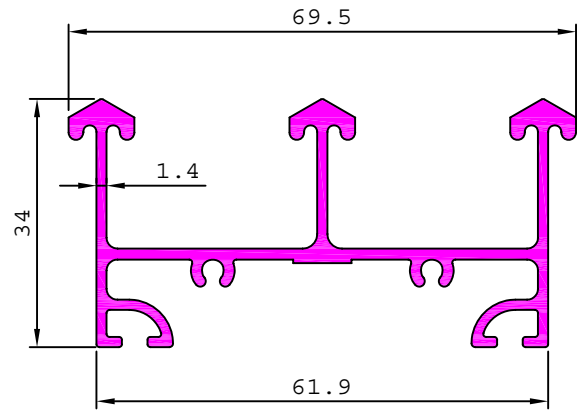

21059

1.468 kg/m

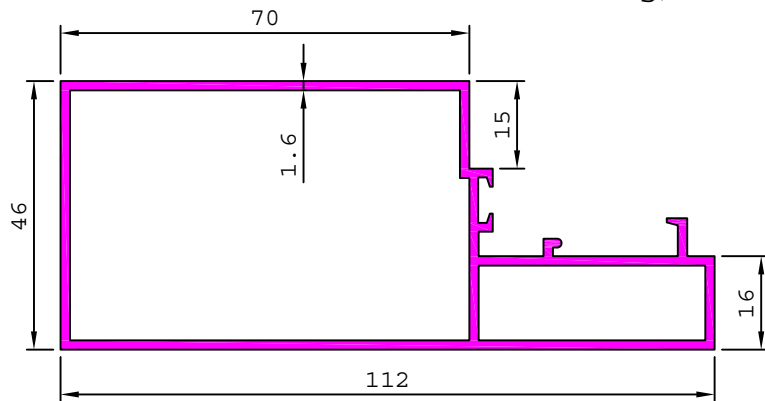

21060

0.933 kg/m

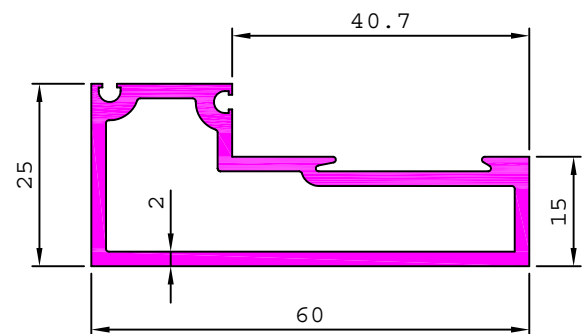

21066

0.597 kg/m

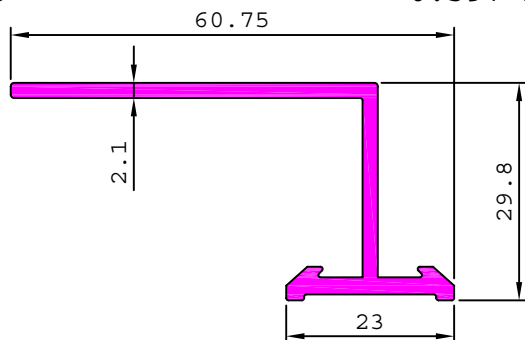

21067

0.824 kg/m

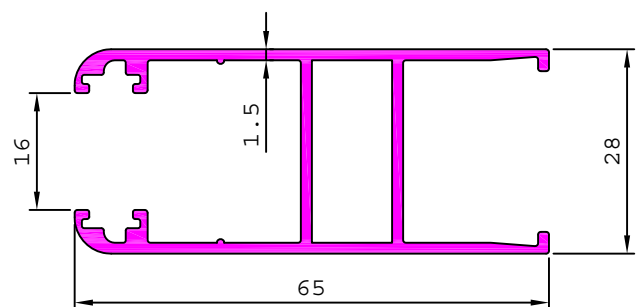

SUPER PROFILE

WINDOW SECTIONS

21068

0.923 kg/m

21069

0.916 kg/m

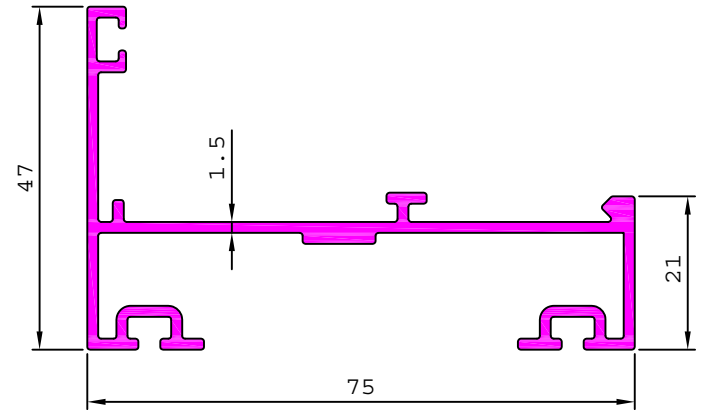
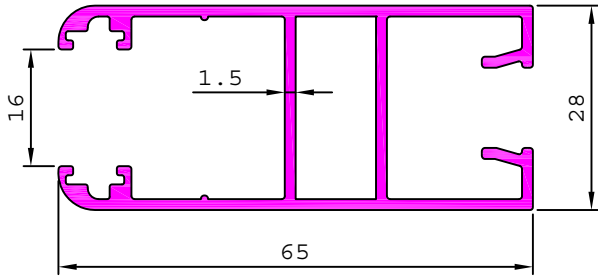

21070

1.373 kg/m

21071

1.458 kg/m

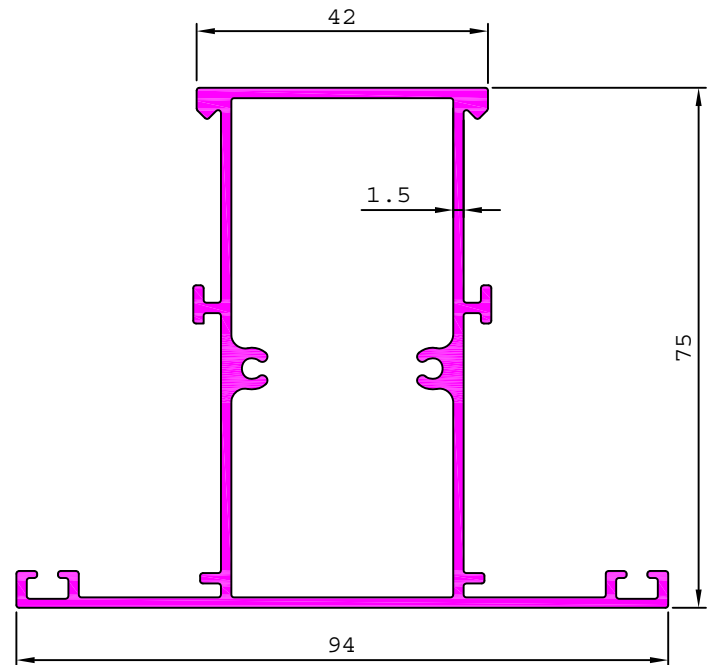
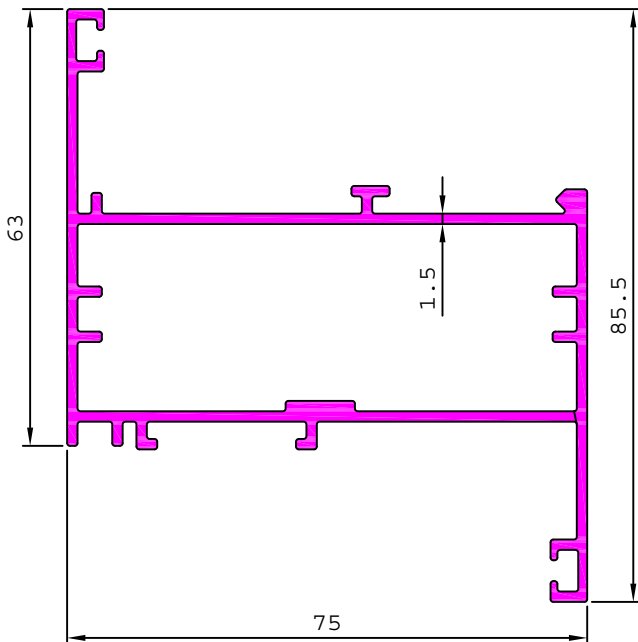

21072

0.994 kg/m

21073

0.824 kg/m

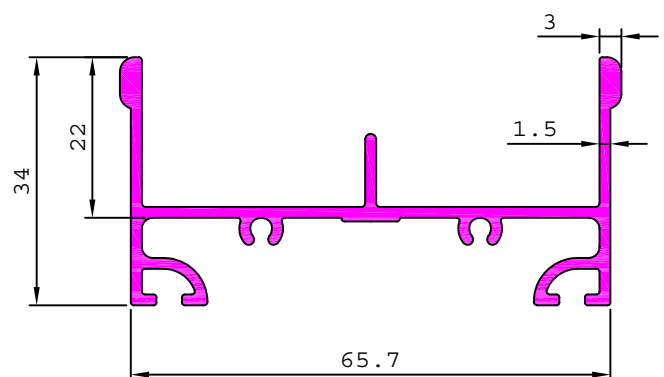
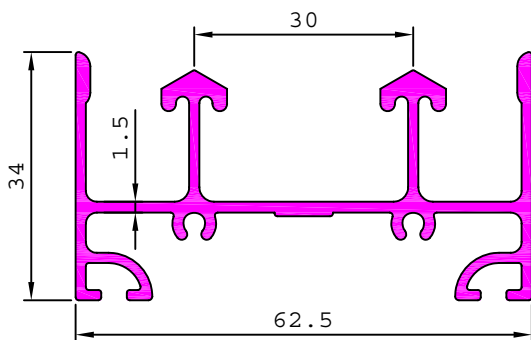

WINDOW SECTIONS

21074 0.536 kg/m

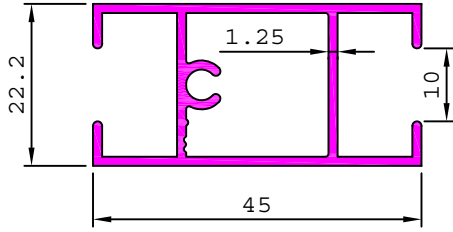

21075 0.492 kg/m

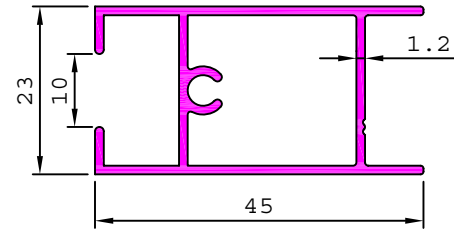

21076 1.472 kg/m

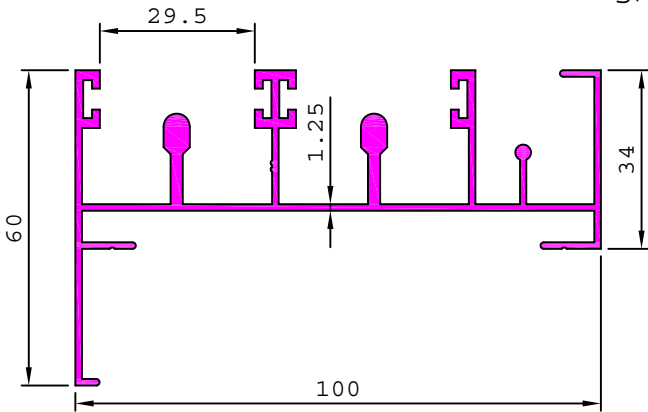

21077 1.121 kg/m

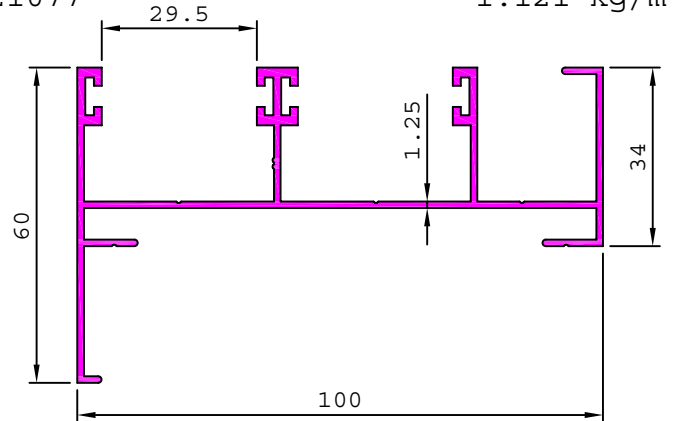

21078 0.826 kg/m

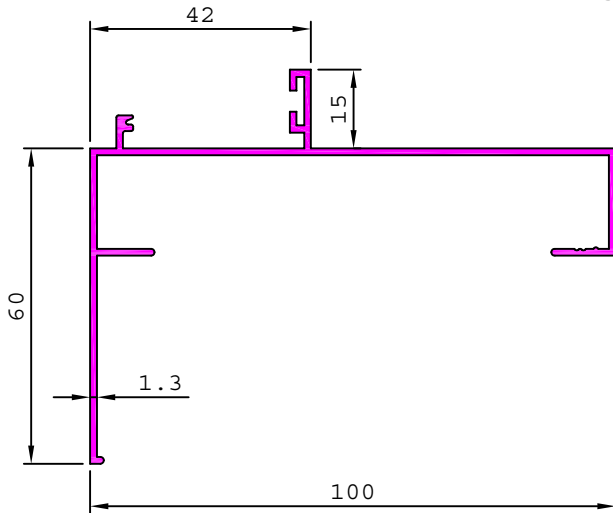

21079 0.827 kg/m

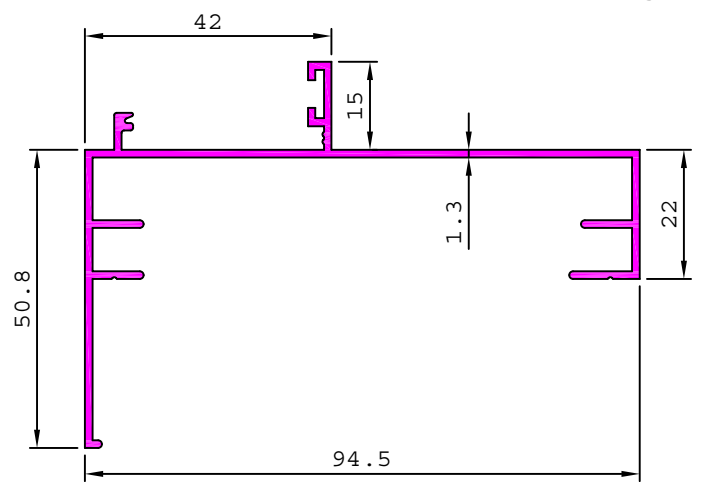

21081 1.047 kg/m

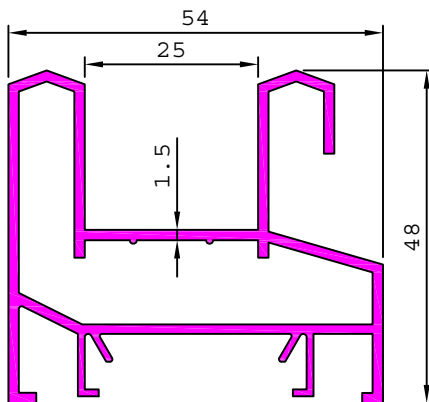

21082 0.662 kg/m

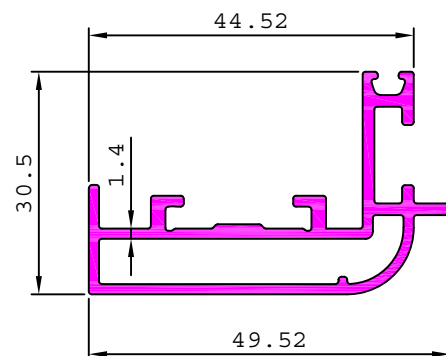

SUPER PROFILE

WINDOW SECTIONS

21083

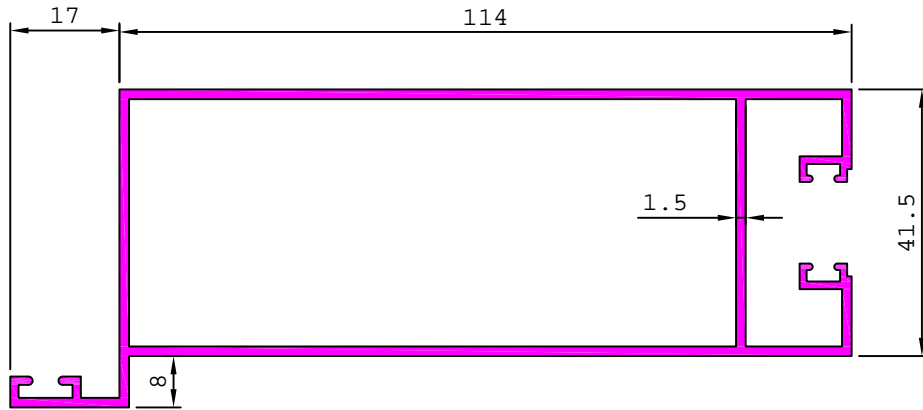

1.544 kg/m

21085

0.798 kg/m

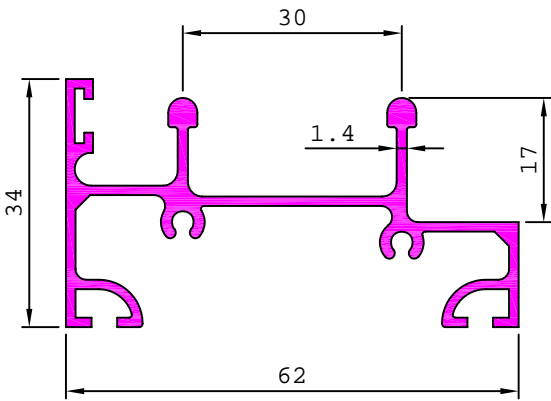

21087

1.543 kg/m

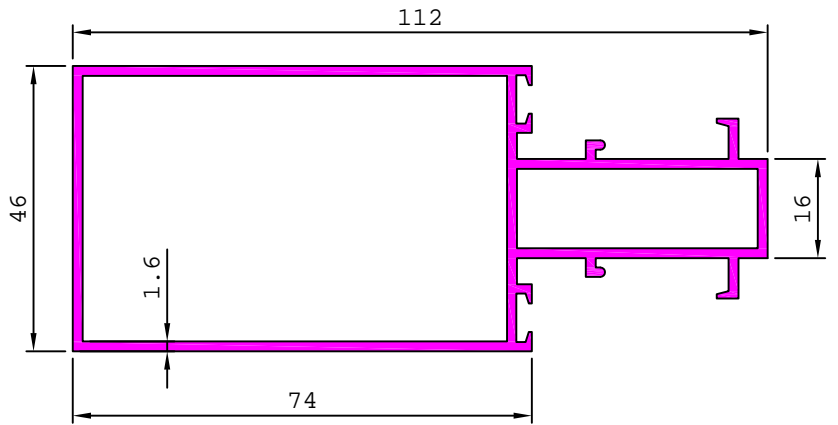

21090

0.775 kg/m

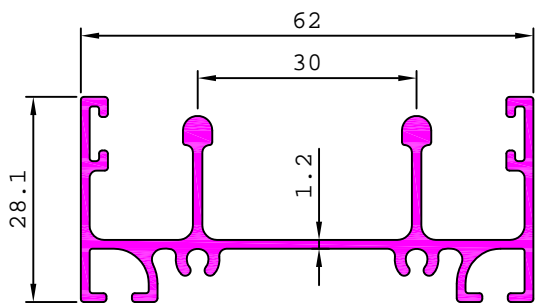

21102

0.826 kg/m

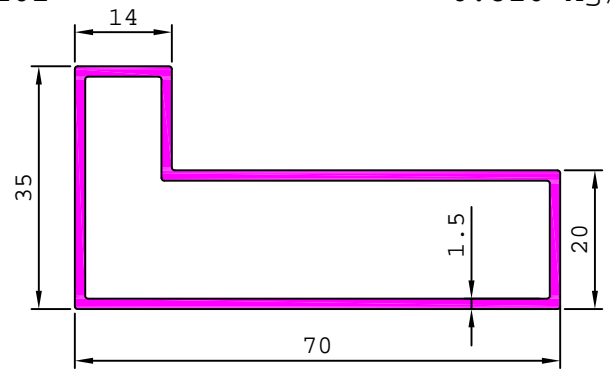

21103

0.811 kg/m

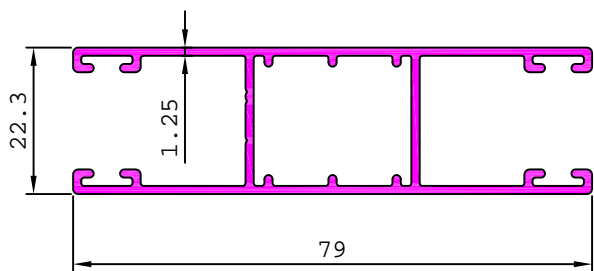

21107

0.550 kg/m

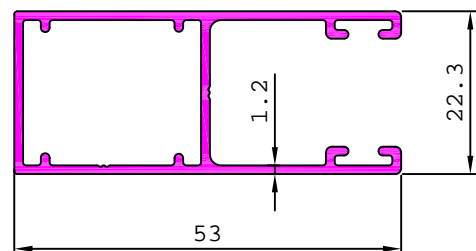

SUPER PROFILE

WINDOW SECTIONS

211108 0.417 kg/m

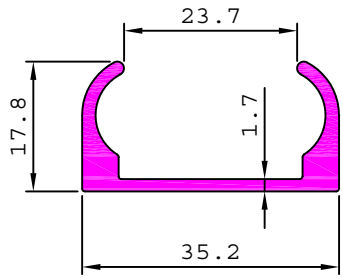

211110 0.258 kg/m

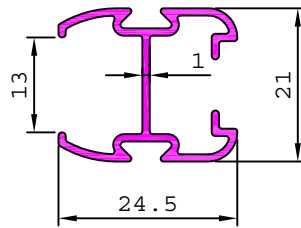

211113 0.331 kg/m

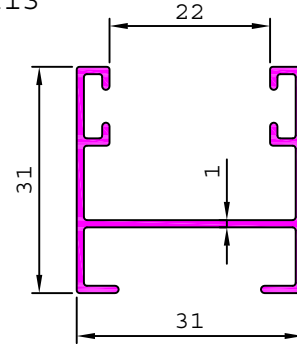

211111 1.097 kg/m

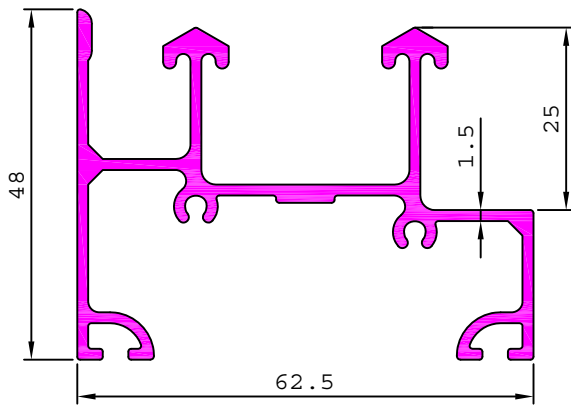

211114 0.412 kg/m

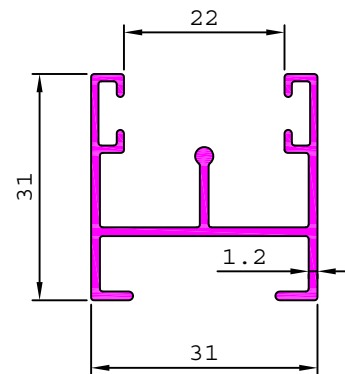

211118 1.436 kg/m

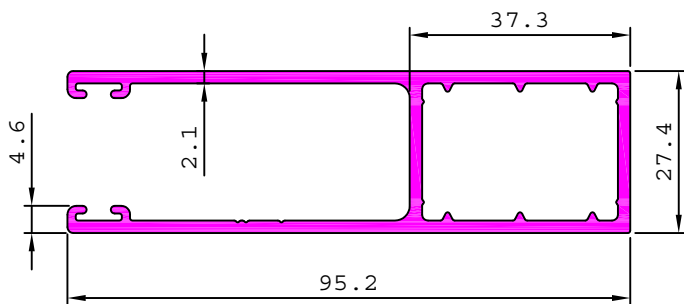

21121 1.331 kg/m

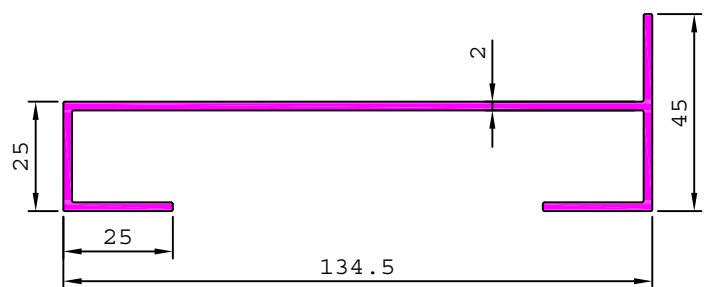

21122 1.895 kg/m

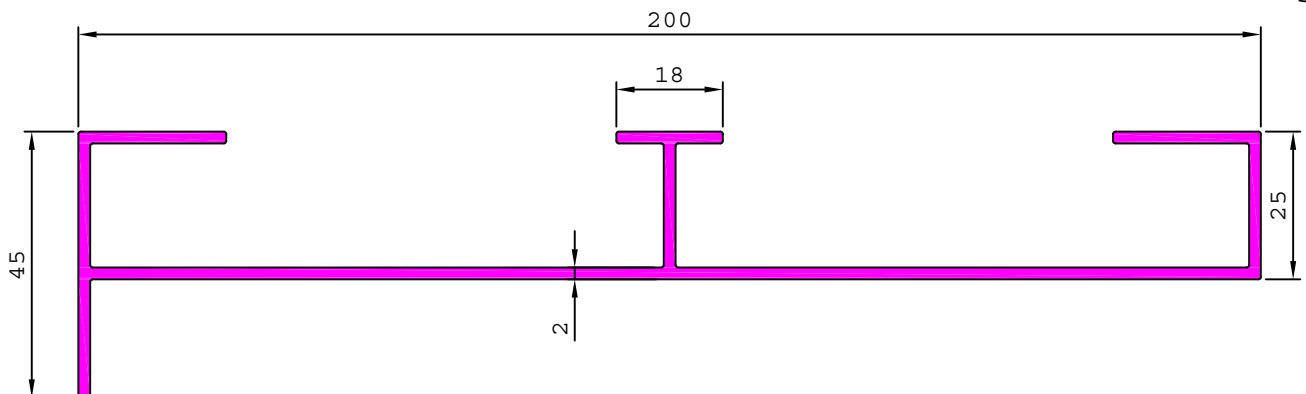

SUPER PROFILE

WINDOW SECTIONS

21123

2.609 kg/m

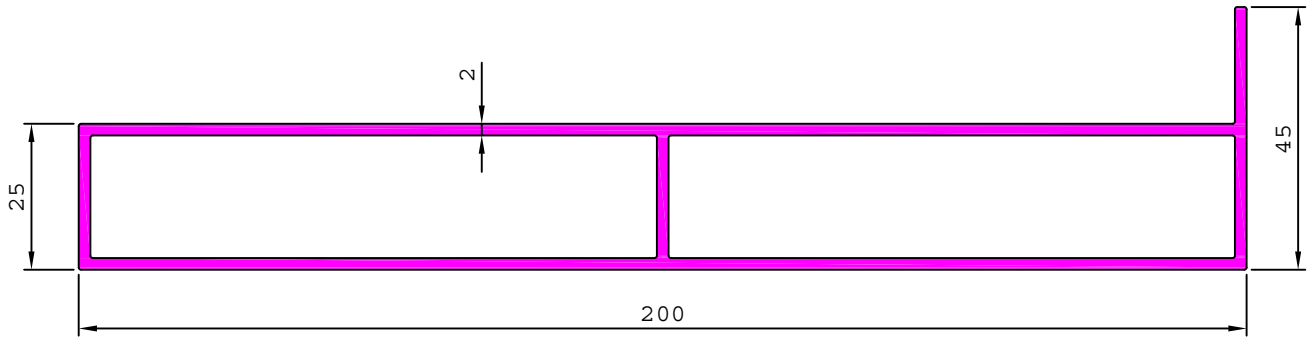

21156

0.836 kg/m

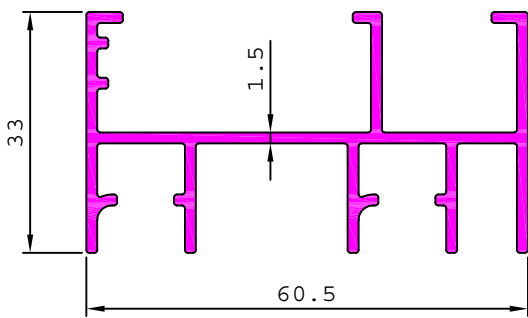

21157

0.680 kg/m

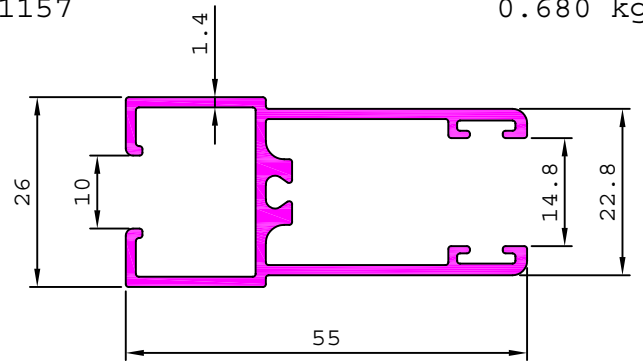

21158

0.675 kg/m

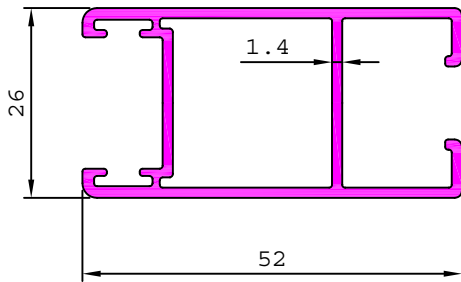

21162

1.020 kg/m

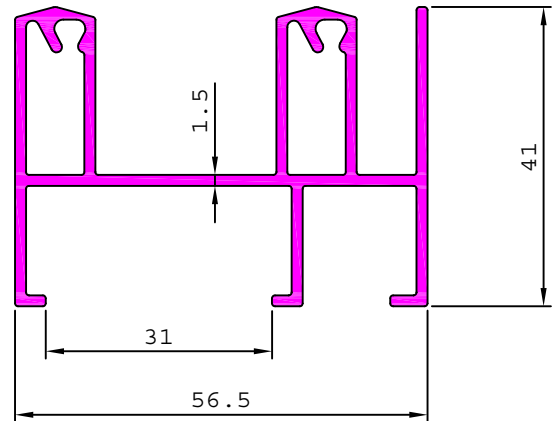

21159

1.969 kg/m

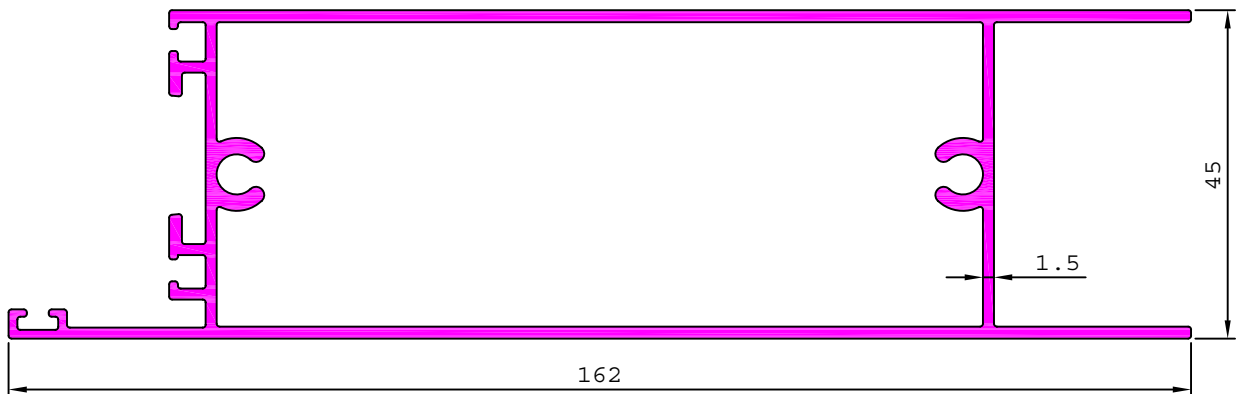

SUPER PROFILE

WINDOW SECTIONS

21163

1.016 kg/m

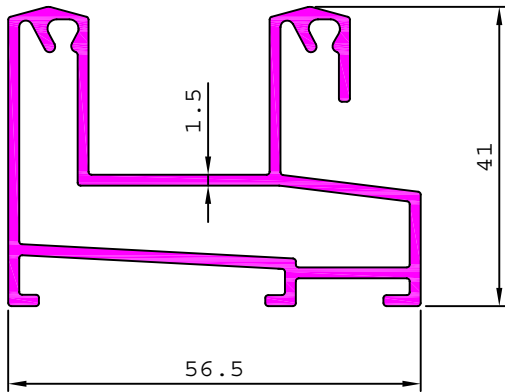

21164

1.434 kg/m

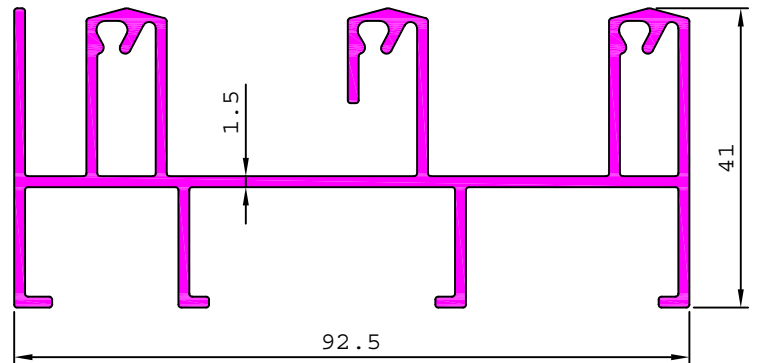

21165

1.047 kg/m

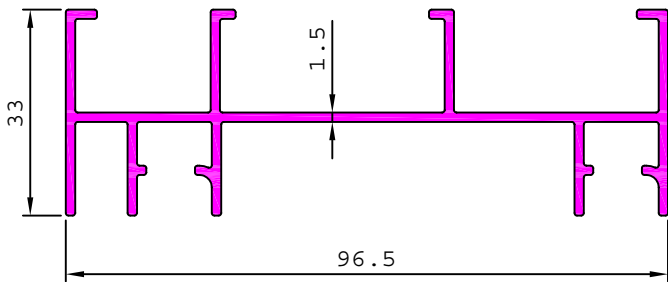

21166

1.569 kg/m

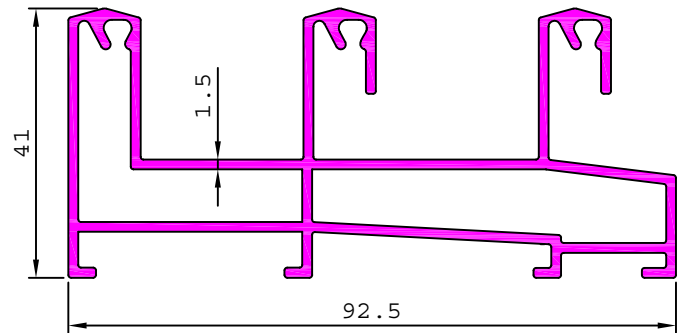

21170

0.669 kg/m

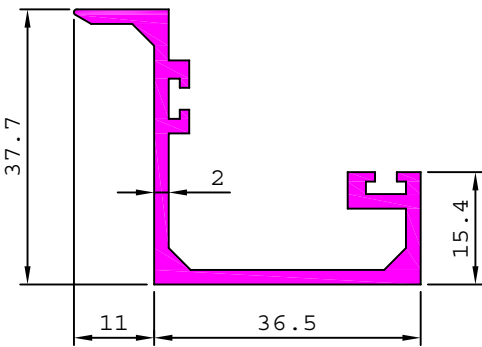

21179

0.174 kg/m

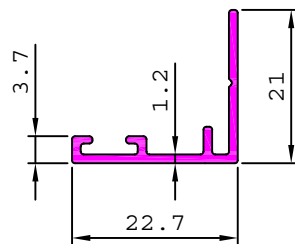

21181

0.171 kg/m

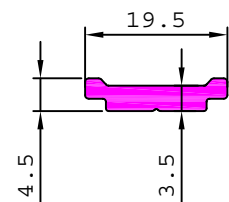

21180

1.478 kg/m

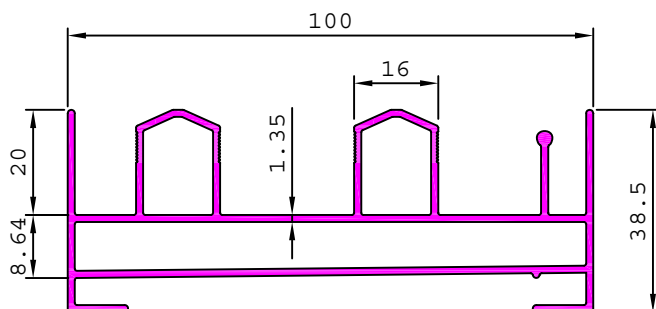

21184

0.891 kg/m

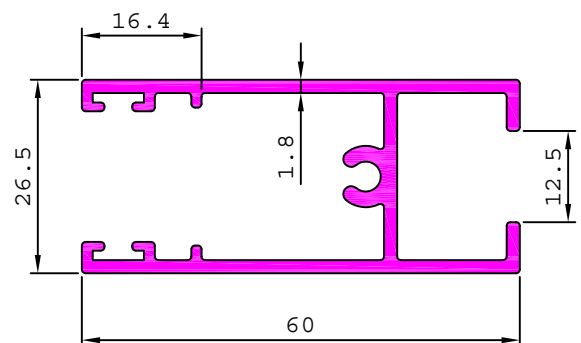

SUPER PROFILE

WINDOW SECTIONS

21183

2.129 kg/m

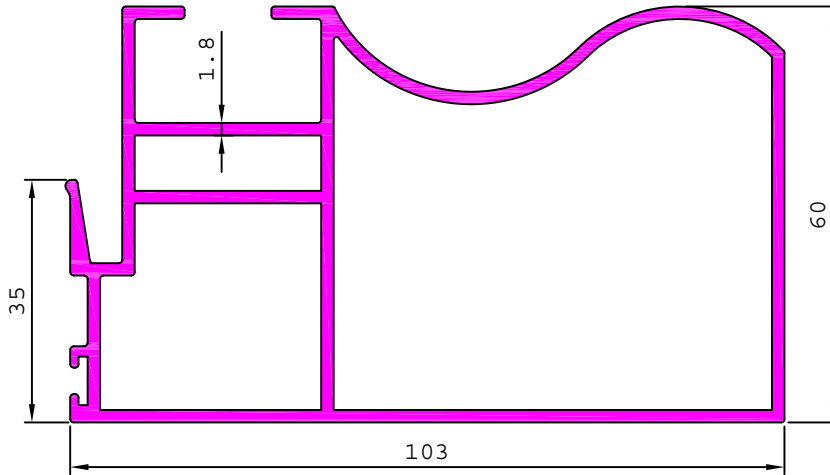

21188

1.548 kg/m

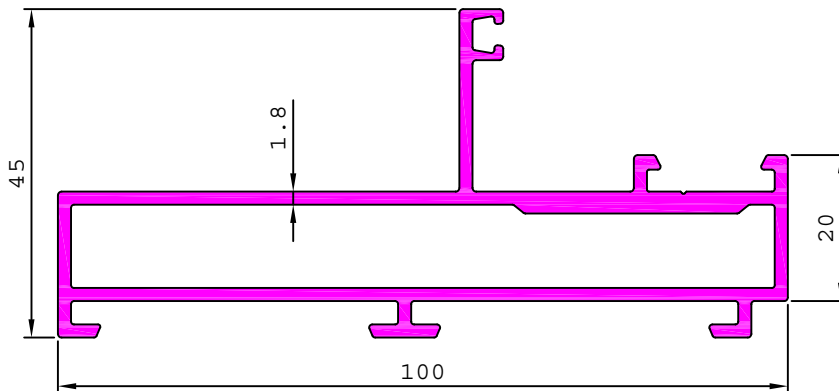

21189

2.168 kg/m

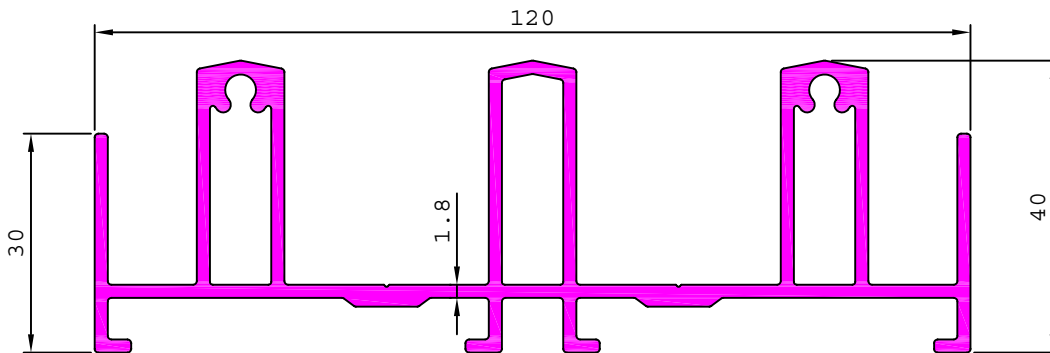

21190

2.429 kg/m

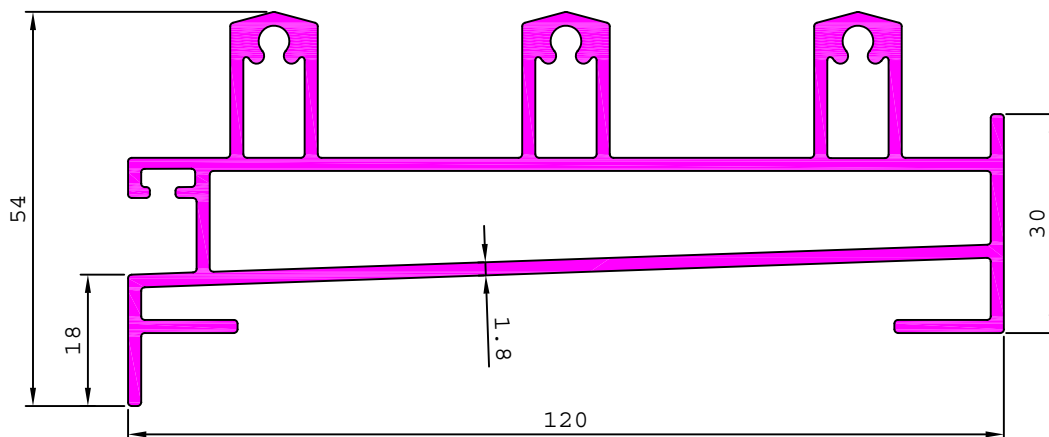

SUPER PROFILE

WINDOW SECTIONS

21191

1.279 kg/m

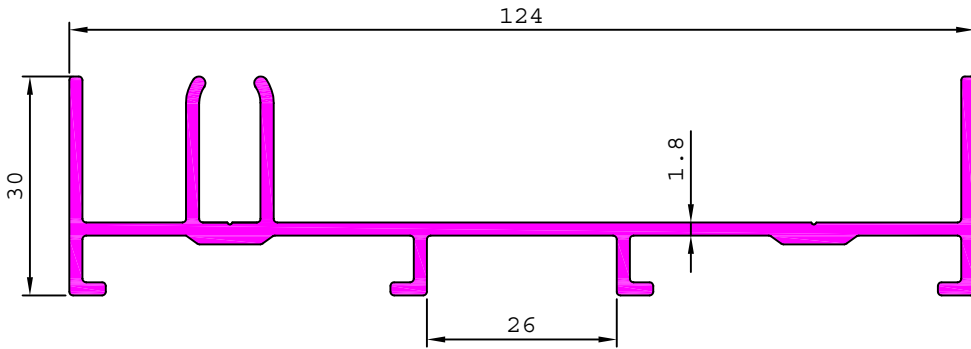

21193

0.345 kg/m

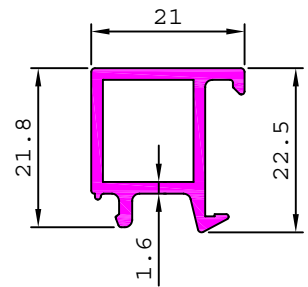

21192

1.691 kg/m

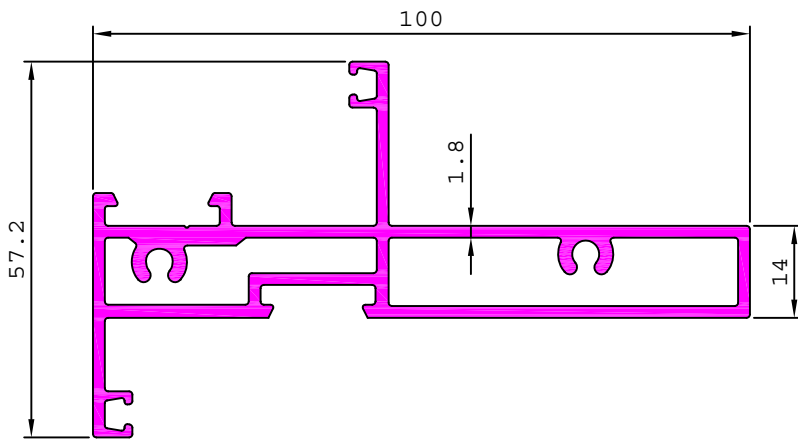

21194

0.389 kg/m

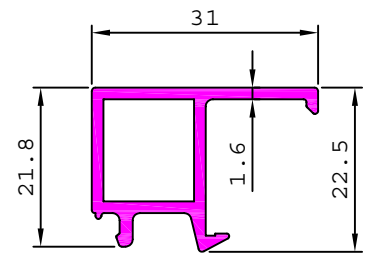

21195

1.004 kg/m

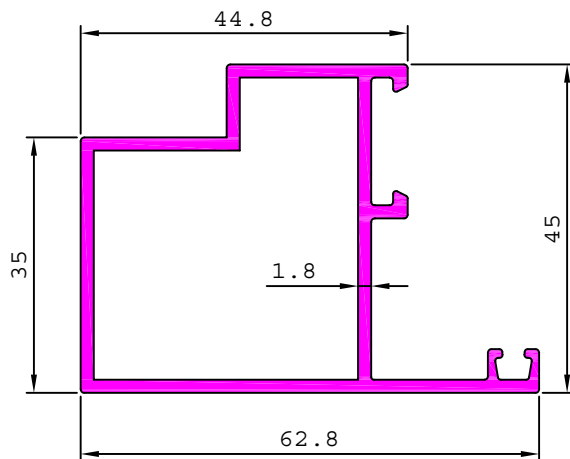

21196

0.509 kg/m

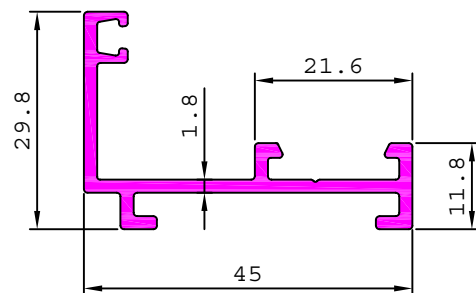

SUPER PROFILE

WINDOW SECTIONS

21199 51 1.709 kg/m

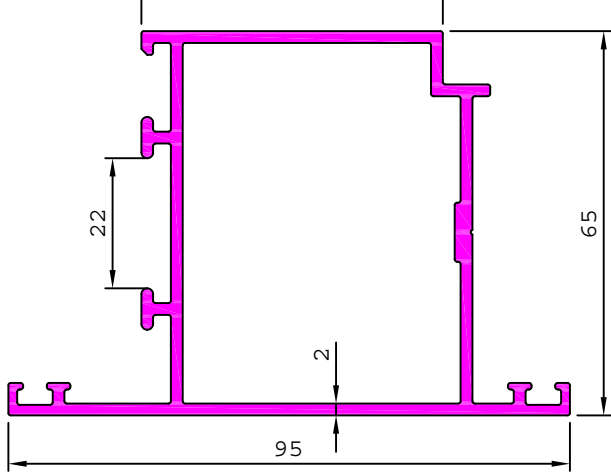

21200 34 1.636 kg/m

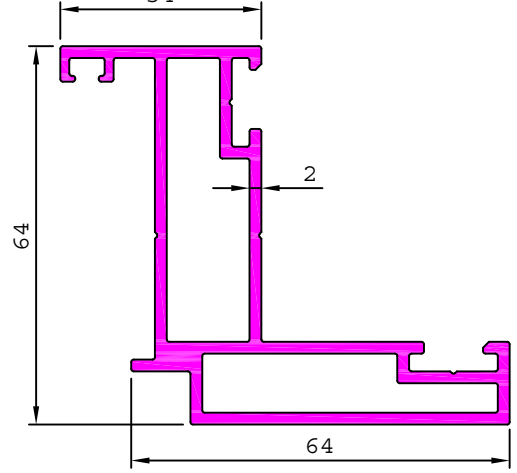

21201 2.477 kg/m

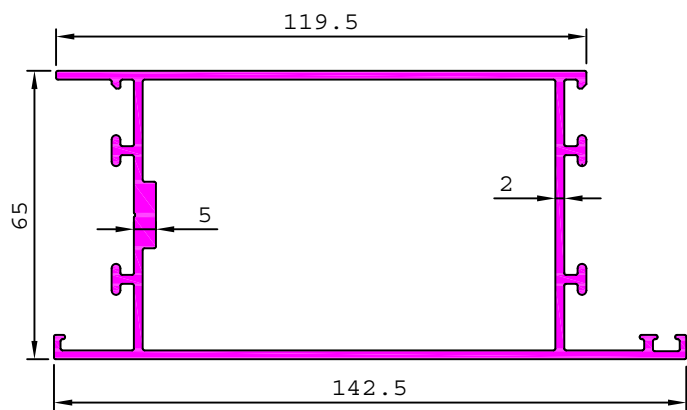

21202 2.485 kg/m

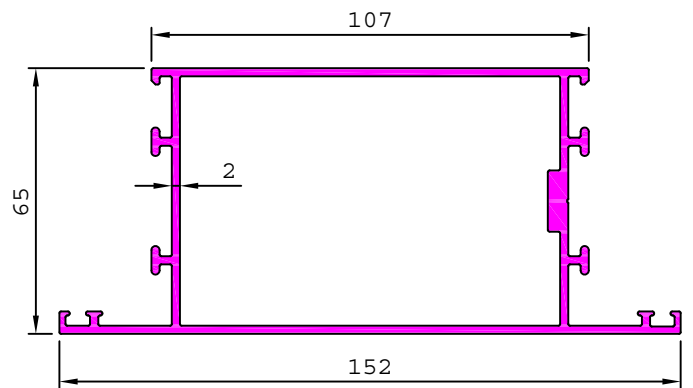

21207 1.268 kg/m

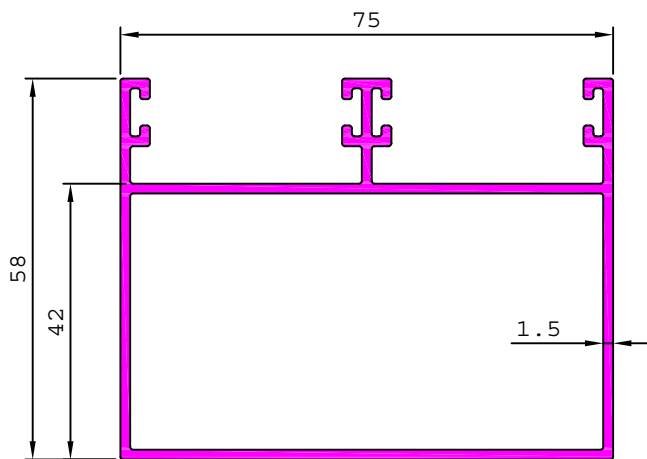

21208 0.982 kg/m

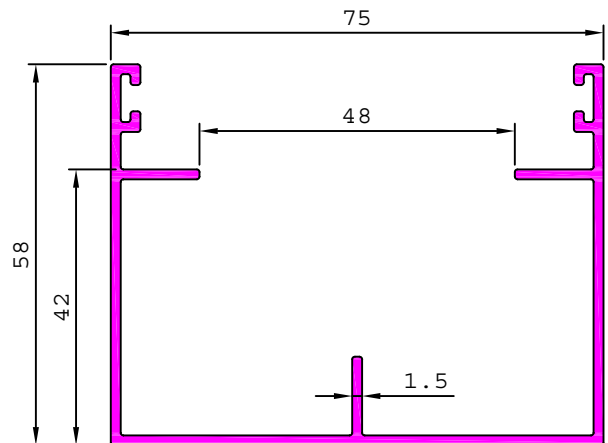

SUPER PROFILE

WINDOW SECTIONS

21210 0.988 kg/m

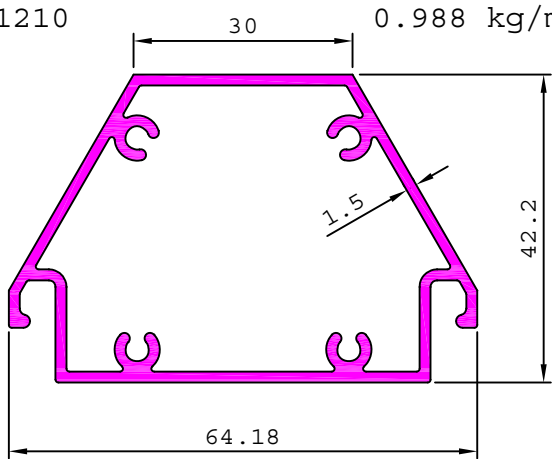

21212 0.866 kg/m

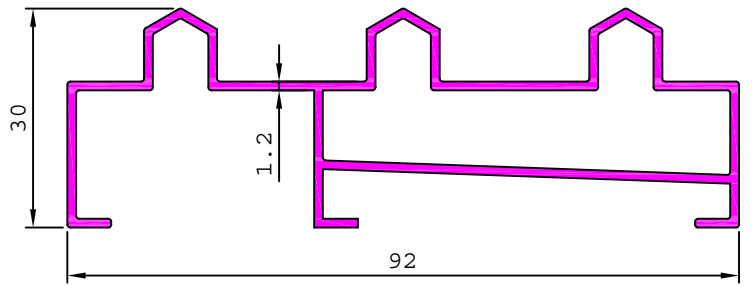

21211 0.666 kg/m

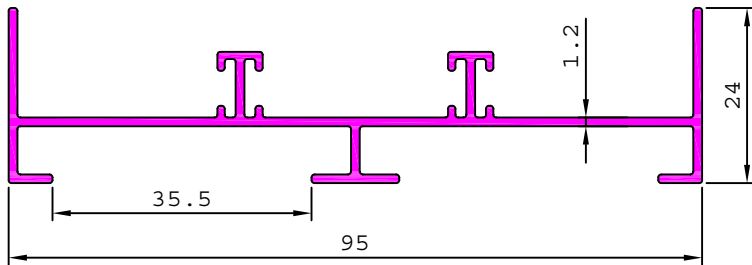

21209 0.425 kg/m

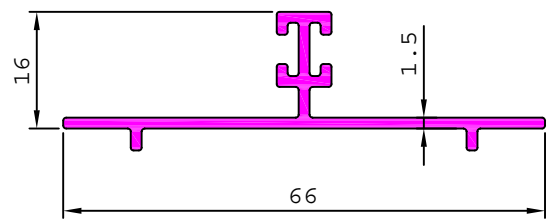

21225 0.839 kg/m

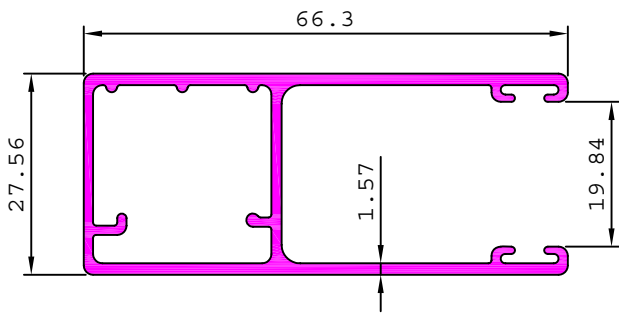

21229 0.674 kg/m

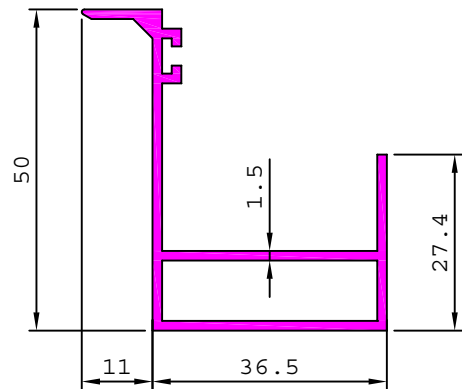

21233 0.290 kg/m

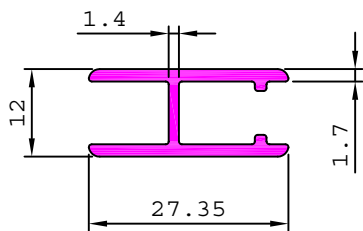

21237 0.714 kg/m

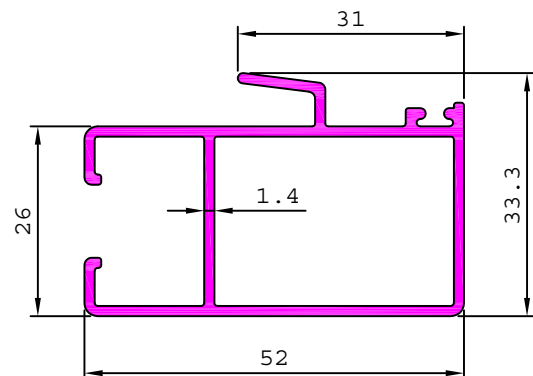

SUPER PROFILE

WINDOW SECTIONS

21239

0.237 kg/m

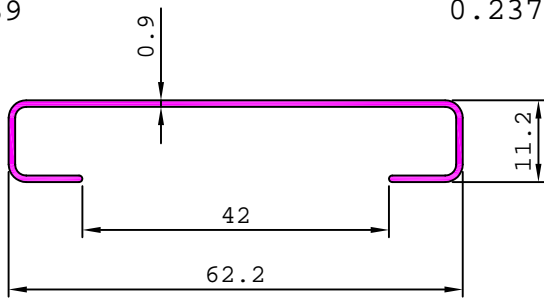

21250

0.909 kg/m

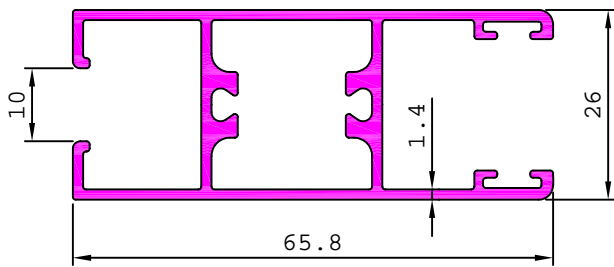

21251

0.431 kg/m

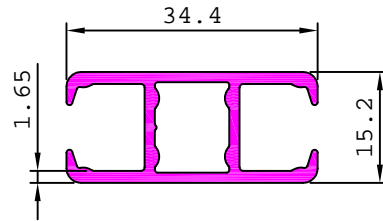

21254

0.399 kg/m

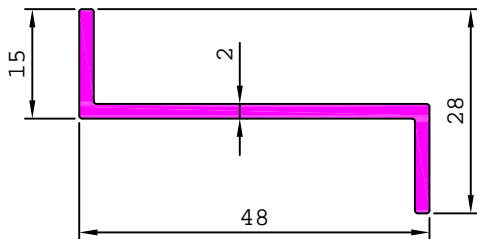

21255

0.154 kg/m

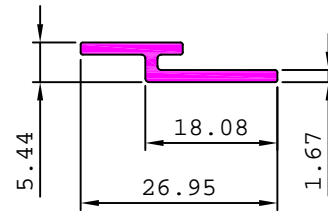

21256

0.810 kg/m

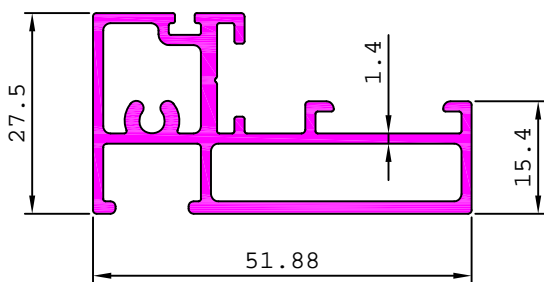

21257

0.935 kg/m

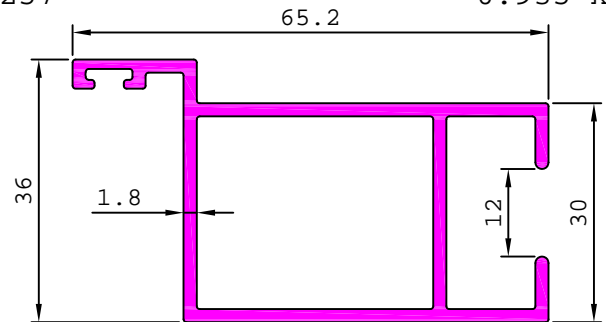

21282

1.859 kg/m

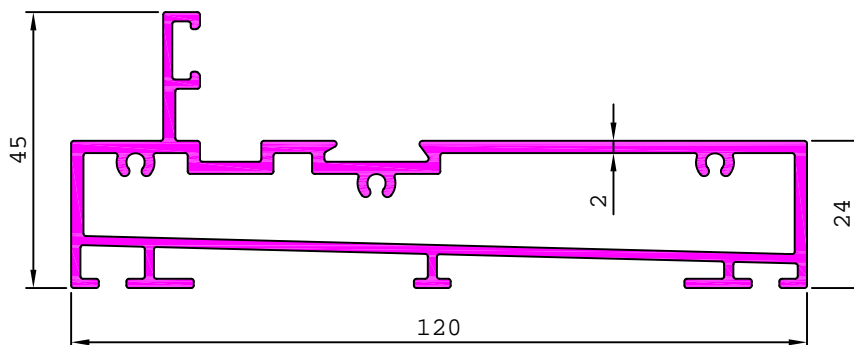

SUPER PROFILE

WINDOW SECTIONS

21273

1.462 kg/m

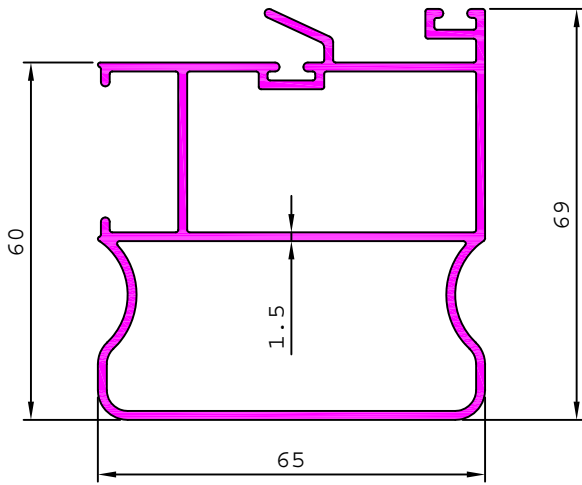

21276

1.238 kg/m

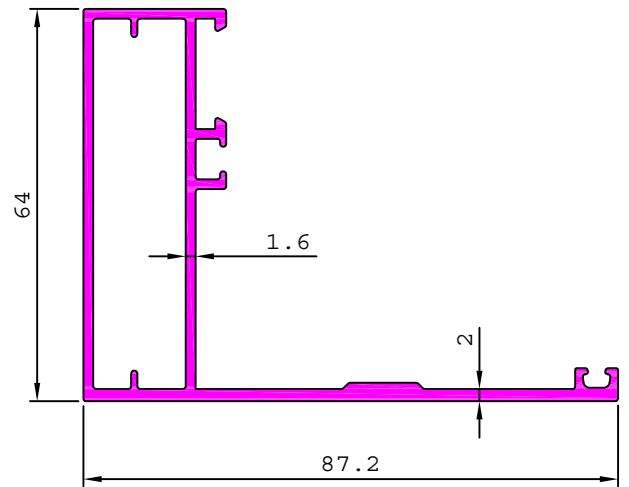

21277

1.493 kg/m

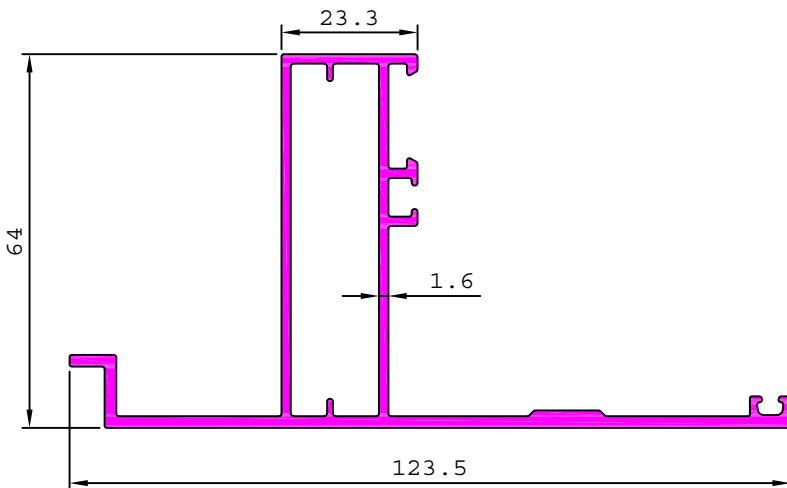

21278

1.106 kg/m

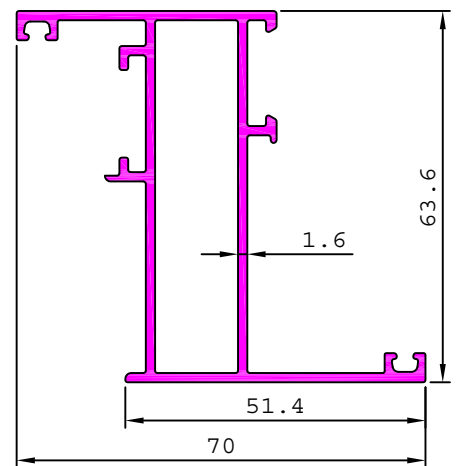

21287

0.346 kg/m

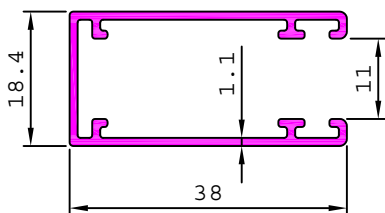

21288

0.605 kg/m

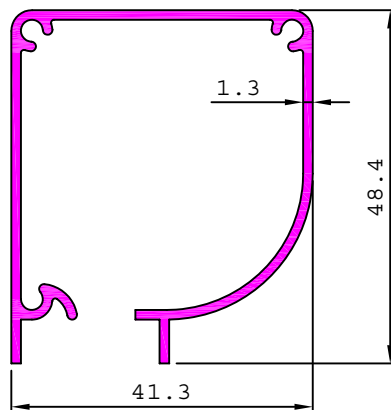

21289

0.329 kg/m

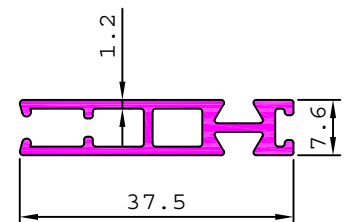

WINDOW SECTIONS

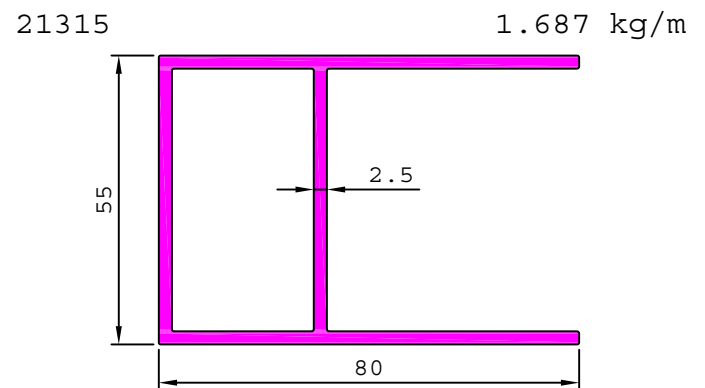
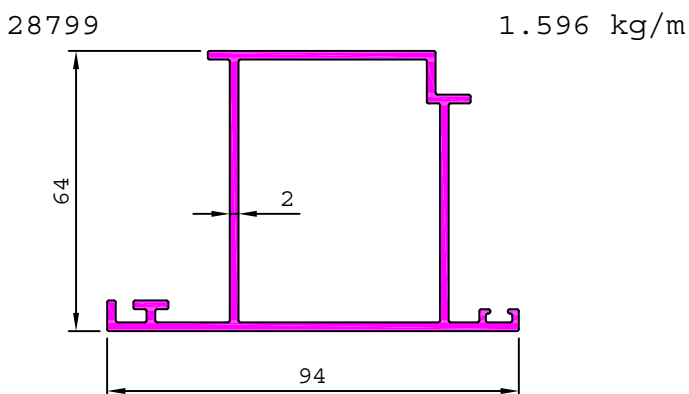
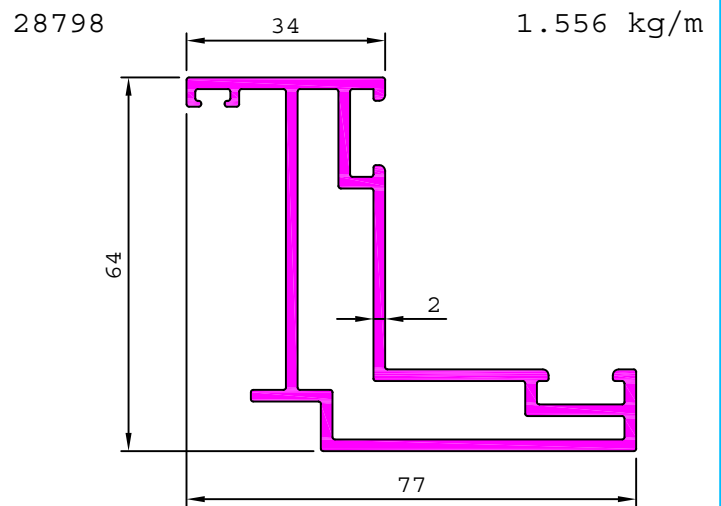
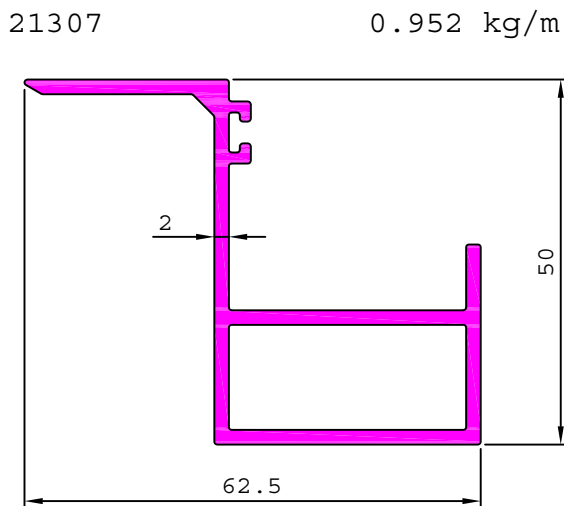
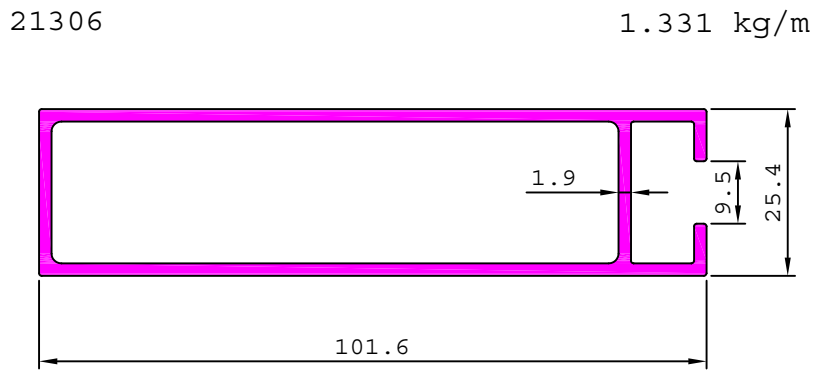
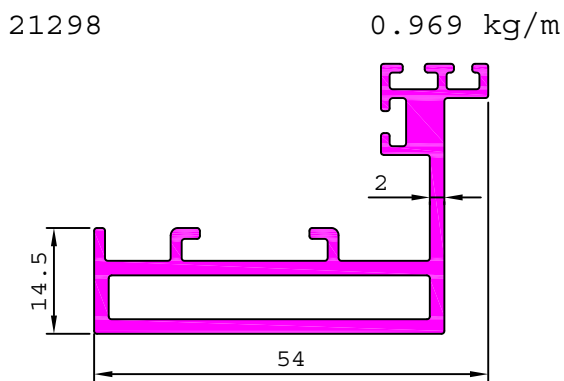
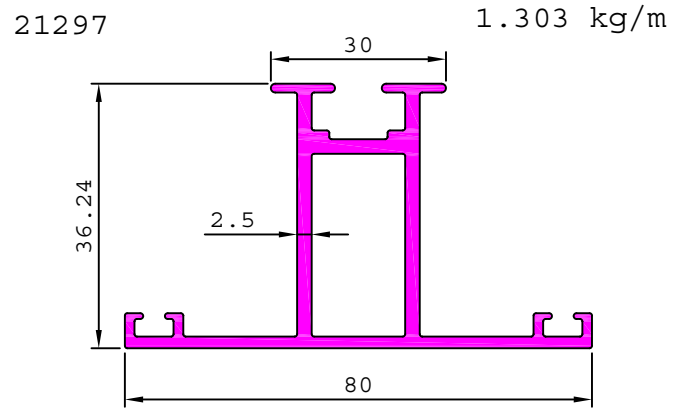
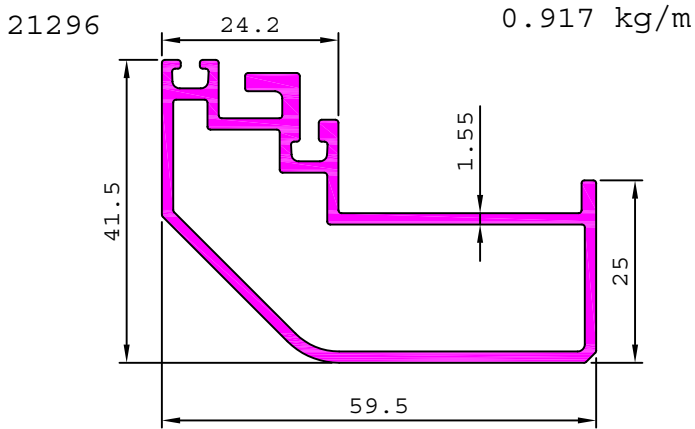

WINDOW SECTIONS

21327

2.663 kg/m

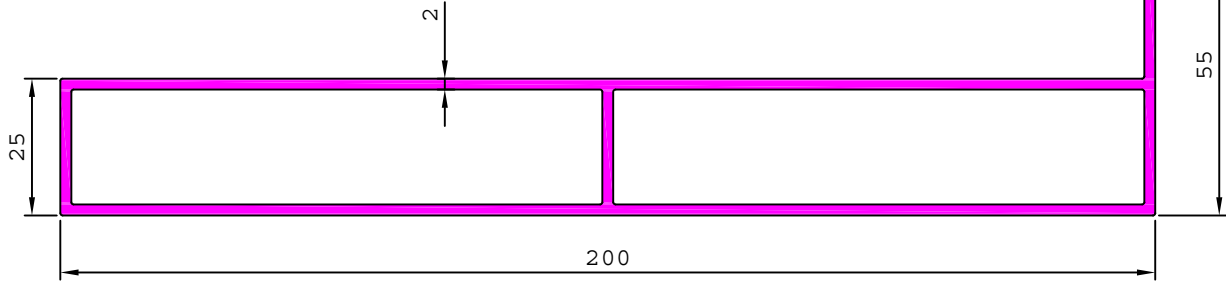

S2223

0.914 kg/m

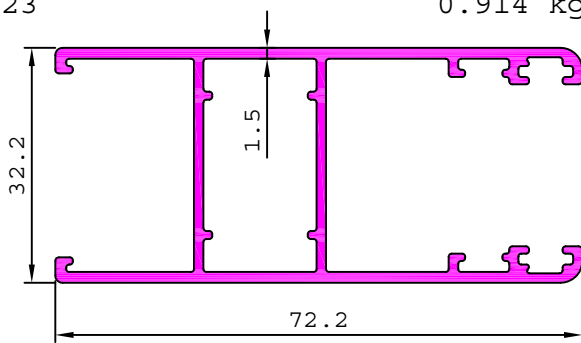

S2224

0.839 kg/m

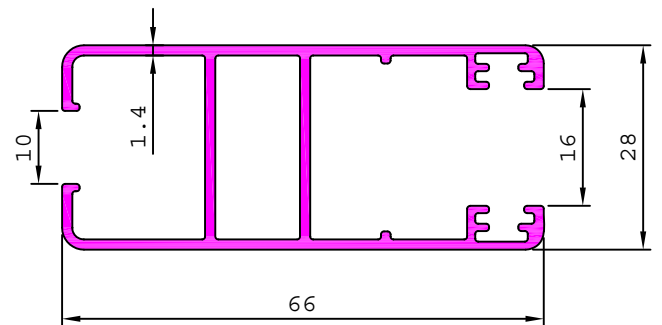

S2226

1.328 kg/m

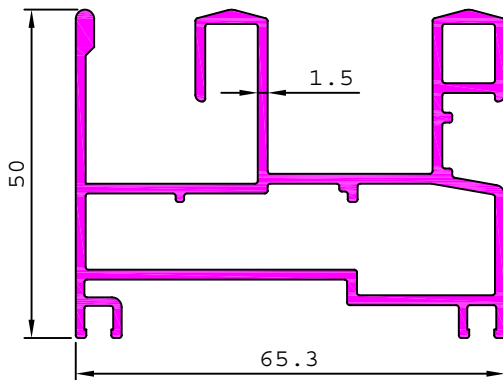

S2227

1.860 kg/m

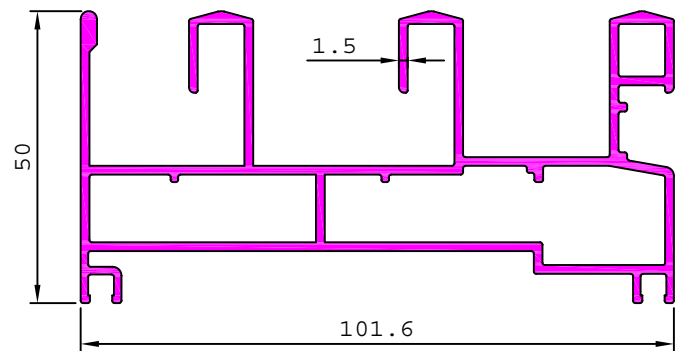

S2228

1.535 kg/m

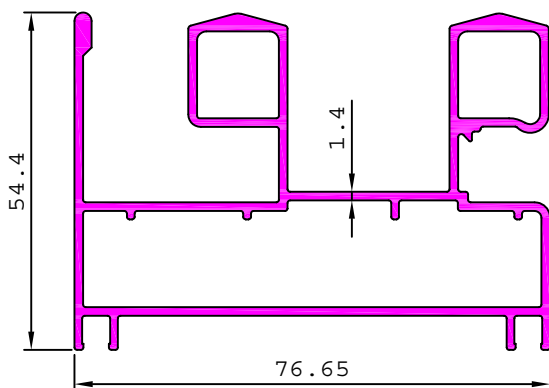

S2288

0.628 kg/m

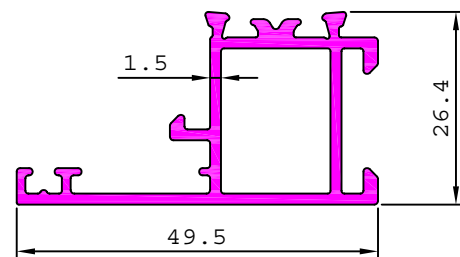

WINDOW SECTIONS

S2229

2.254 kg/m

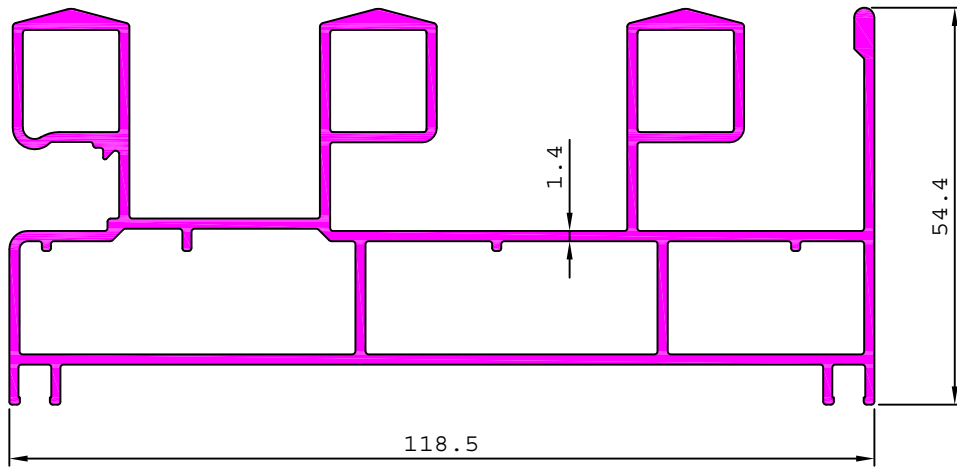

S2289

0.773 kg/m

S2290

0.631 kg/m

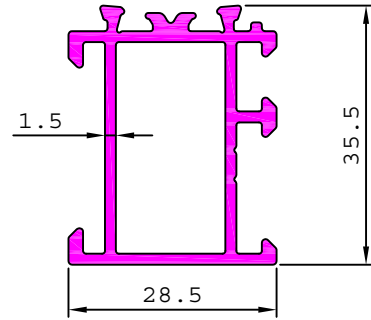
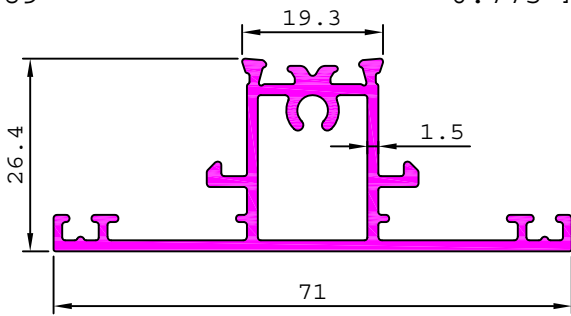

S2291

0.705 kg/m

S2347

1.007 kg/m

21329

0.168 kg/m

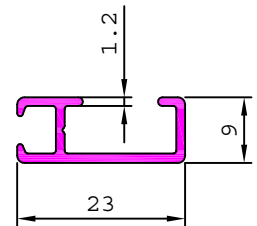
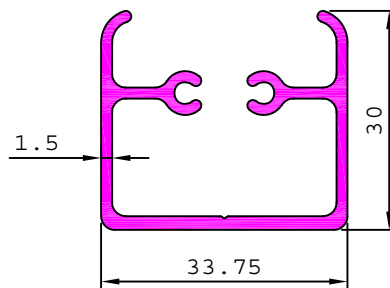
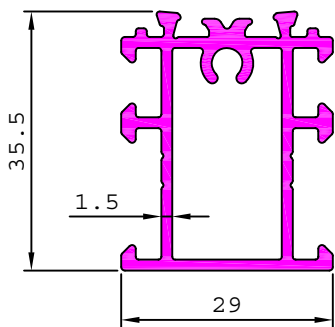

21317

0.555 kg/m

21319

0.612 kg/m

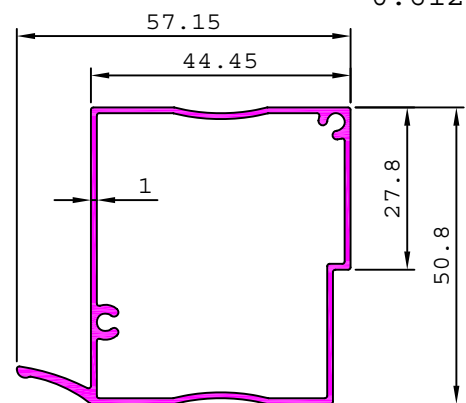
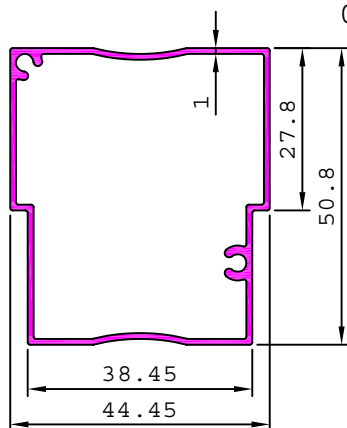

WINDOW SECTIONS

S2357

3.365 kg/m

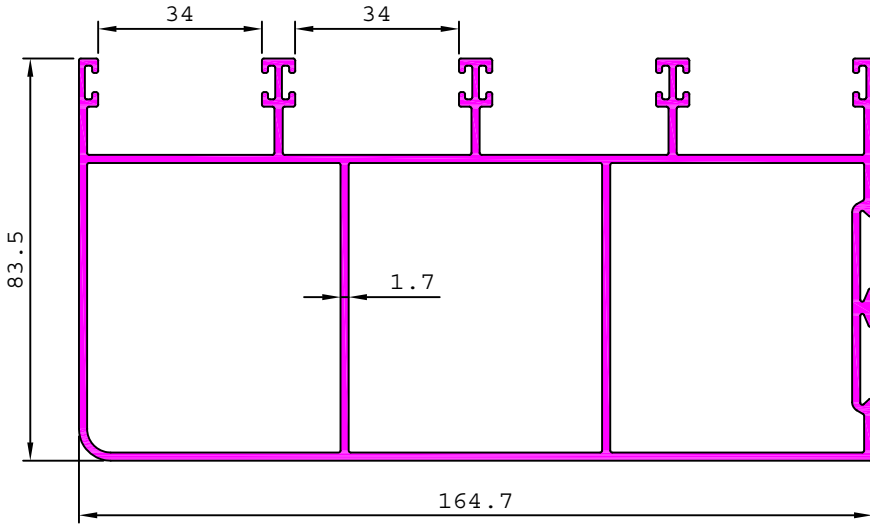

S2364

0.860 kg/m

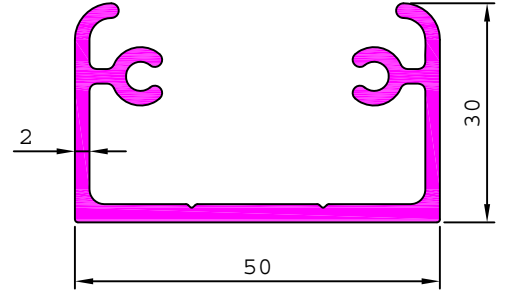

S2571

0.527 kg/m

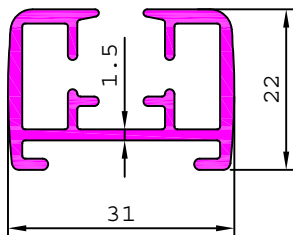

S2573

0.219 kg/m

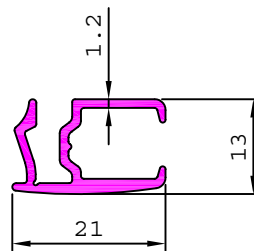

S2574

0.340 kg/m

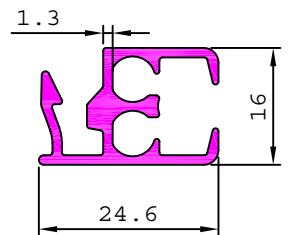

S2572

0.671 kg/m

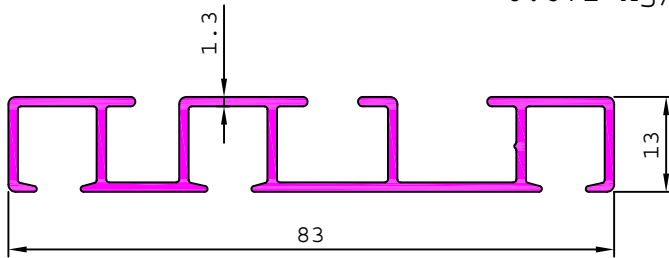

S2632

0.716 kg/m

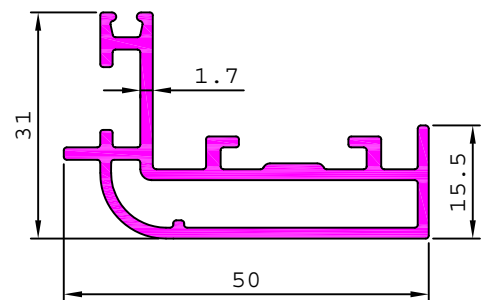

S2663

1.366 kg/m

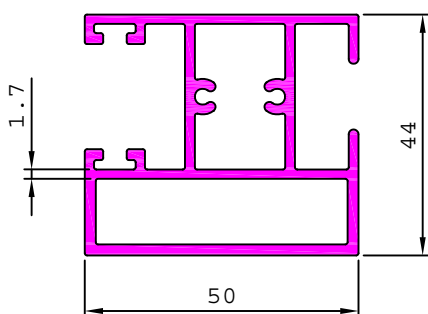

21328

0.899 kg/m

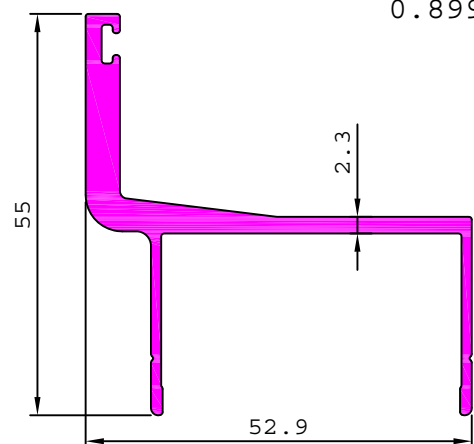

SUPER PROFILE

WINDOW SECTIONS

21331

0.957 kg/m

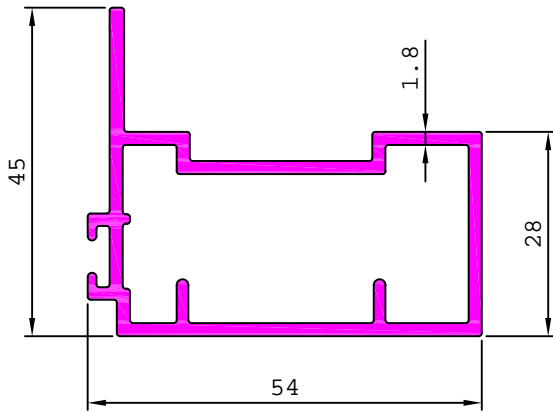

21332

0.578 kg/m

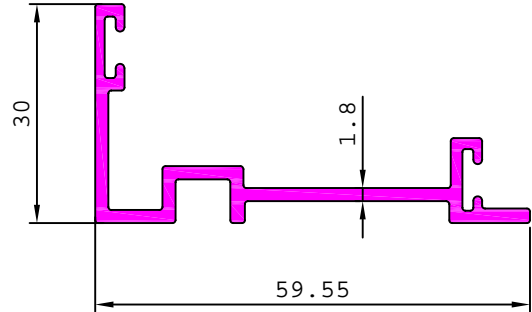

S2836

0.541 kg/m

