

# II. SLIDING WINDOW

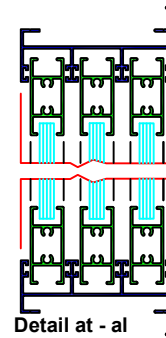
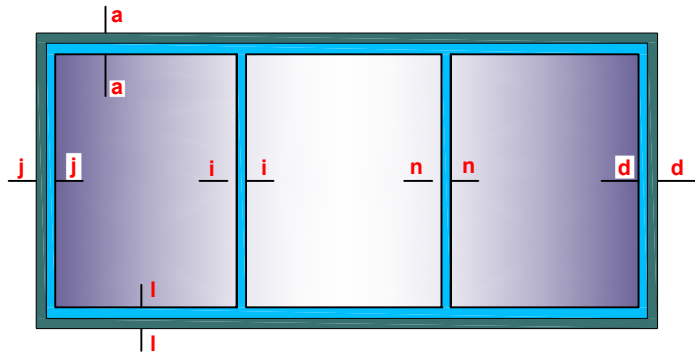

Sliding windows are becoming increasingly popular because they are easy to operate and do not occupy space either on the interior or on the exterior.

There are several series ranging from two-track to four-track.

They are capable of being fabricated in heights ranging from a standard 4' to as high as 10'. The windows have very sophisticated facilities such as interlocking sections, grooves for weather strip, provisions for fixing locks and mosquito mesh on the outer track.

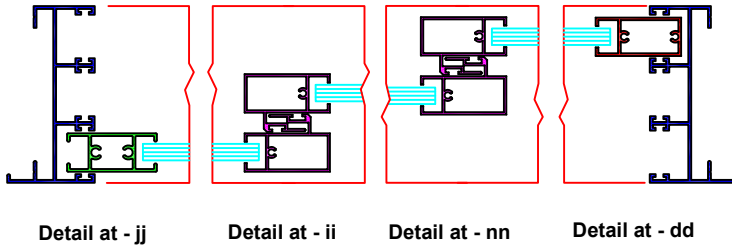

## JINDAL SECTION NUMBERS FOR SLIDING WINDOWS

SECTION DESCRIPTION	SERIES - A (15 mm)			SERIES - B (18 mm)			SERIES - C (20 mm)			SERIES - D (25 mm)		
	2 TRACK	3 TRACK	4 TRACK	2 TRACK	3 TRACK	4 TRACK	2 TRACK	3 TRACK	4 TRACK	2 TRACK	3 TRACK	4 TRACK
SHUTTER TOP & BOTTOM	20597	20213	20213	20545	20545	20545	20529	20529		20506	20506	20506
	20688	20581	20581	20567	20567	20567	20551	20551		20518	20518	20518
	20809	20597	20597	20604	20604	20604	20567	20567		20528	20528	20528
		20688	20688	20652	20652	20652	20710	20710		20639	20639	20639
		20690	20690	20736	20736	20736	20988	20988		20716	20716	20716
		20718	20718	20750	20750	20750			----	20801	20801	20801
		20809	20809	20803	20803	20803				20842	20842	20842
		20945	20945	20805	20805	20805						
		20969	20969	20811	20811	20811						
				20844	20844	20844						
				20847	20847	20847						
				20963	20963	20963						
	SHUTTER TOP & BOTTOM	20598	20584	20584	20546	20546	20546	20531	20531		20508	20508
20655		20598	20598	20576	20576	20576	20566	20566		20517	20517	20517
20689		20612	20612	20605	20605	20605	20708	20708		20711	20711	20711
20810		20655	20655	20684	20684	20684	20840	20840		20741	20741	20741
		20689	20810	20686	20686	20686	20976	20976		20939	20939	20939
		20810	20868	20691	20691	20691	21052	21052				
		20868	20947	20731	20731	20731			----			
		20947		20737	20737	20737						
				20804	20804	20804						
				20806	20806	20806						
				20845	20845	20845						
				20892	20892	20892						
SHUTTER SIDE (HANDLE)		20668	20596	20596	20547	20547	20547	20530	20530		20507	20507
	20688	20656	20656	20577	20577	20577	20544	20544		20516	20516	20516
		20668	20668	20606	20606	20606	20709	20709		20543	20543	20543
		20688	20688	20685	20685	20685	20931	20931		20602	20602	20602
		20689	20689	20687	20687	20687	20968	20968		20707	20707	20707
		20951	20951	20738	20738	20738	20975	20975		20715	20715	20715
		20964	20964	20802	20802	20802			----	20841	20841	20841
				20807	20807	20807				20857	20857	20857
				20846	20846	20846				21030	21030	21030
				20887	20887	20887				21056	21056	21056
				20893	20893	20893						
FRAME BOTTOM	20669	20624	20583	20619	20620	20636	20703	20704	20910	20633	20677	20797
		20664	20614	20813	20815	20667	21053	20977		20712	20717	20800
		20671	20625	20830	20832	20706		21055		20873	20798	
		20808		20956	20957	20818						
		20946				20834						
FRAME - BOTTOM WITH GUTTER	----	20616	20618	20645	20617	20674	20695	20697	----	20676	20673	----
		20622	20955	20657	20814							
		20626		20965	21031							
		20954										
		20959										
FRAME TOP & SIDE	20670	20672	20583	20681	20621	20635	20694	20696	20911	20634	20678	20796
		20960	20614	20812	20702	20666	20987	20978		20713	20714	20799
			20705	20829	20816	20817		21054		20732	21032	
				20966	20831	20833				20874		
					20958							

# SUPER PROFILE

## DETAILS OF SLIDING WINDOW SECTIONS

### SERIES - A 15 mm.

### PART I - S/W 1/2"

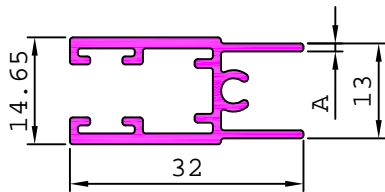

SL. No.	Section No.	A	Weight kg/m
1	20969	0.80	0.233
2	20945	0.90	0.263
3	20581	1.10	0.344

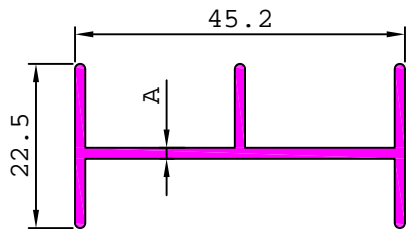

SL. No.	Section No.	A	Weight kg/m
1	20946	0.89	0.238

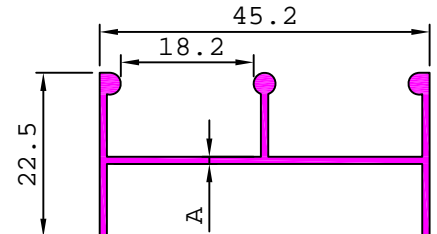

SL. No.	Section No.	A	Weight kg/m
1	20624	1.20	0.353
2	20961	1.00	0.304

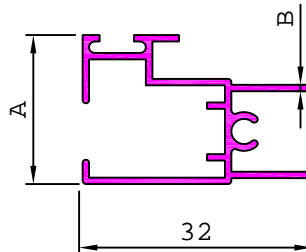
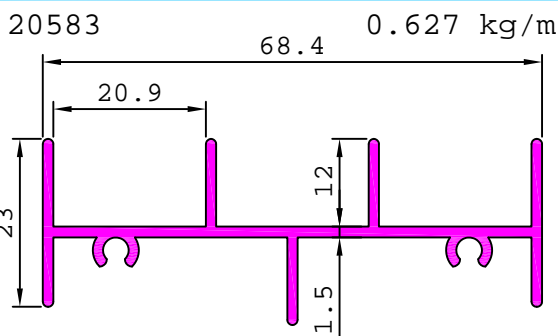

SL. No.	Section No.	A	B	Weight kg/m
1	20868	20.50	0.70	0.220
2	20947	20.75	0.82	0.257
3	20584	20.75	1.10	0.335

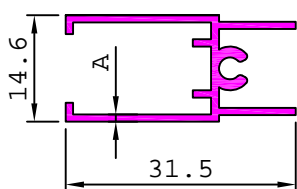

SL. No.	Section No.	A	Weight kg/m
1	20718	1.00	0.263

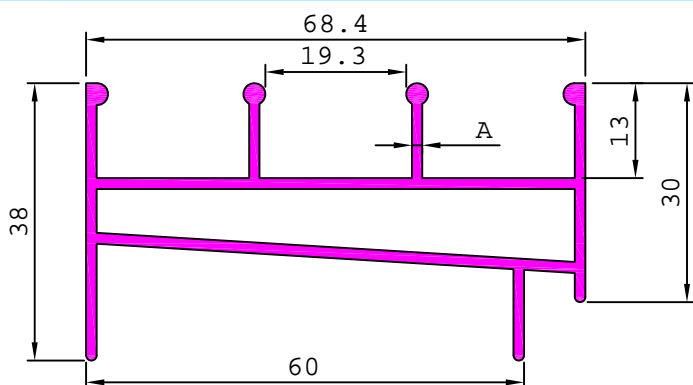
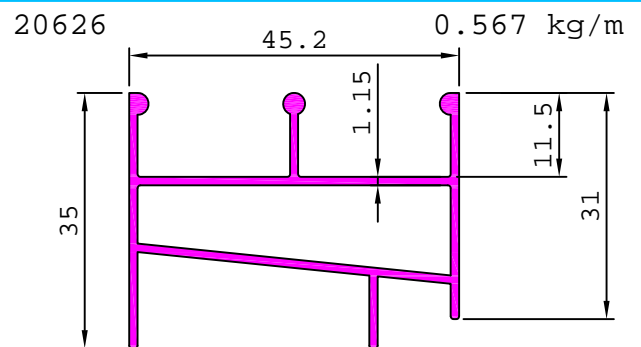

SL. No.	Section No.	A	Weight kg/m
1	20955	1.13	0.759
2	20618	1.50	0.980

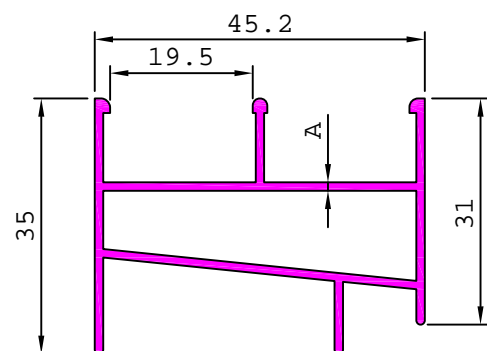

SL. No.	Section No.	A	Weight kg/m
1	20954	1.07	0.496
2	20616	1.15	0.546

# SUPER PROFILE

## DETAILS OF SLIDING WINDOW SECTIONS

### SERIES - A 15 mm.

#### PART I - S/W 1/2"

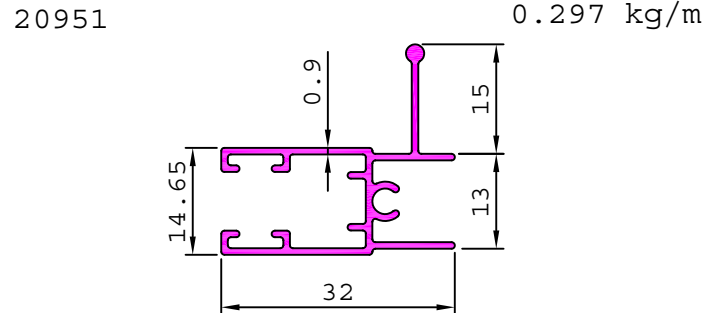
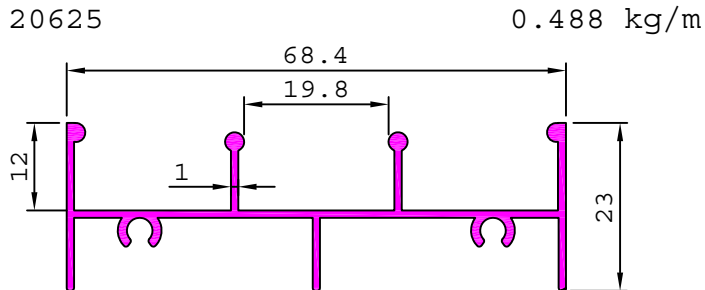

#### PART II - S/W 5/8"

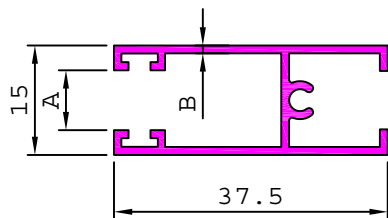

SL. No.	Section No.	A	B	Weight kg/m
1	20809	8.20	1.08	0.329
2	20597	7.80	1.60	0.485

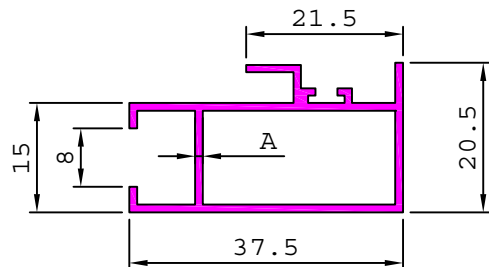

SL. No.	Section No.	A	Weight kg/m
1	20810	1.07	0.369
2	20655	1.50	0.482

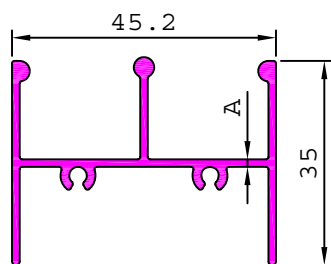

SL. No.	Section No.	A	Weight kg/m
1	20808	0.98	0.414
2	20664	1.30	0.551

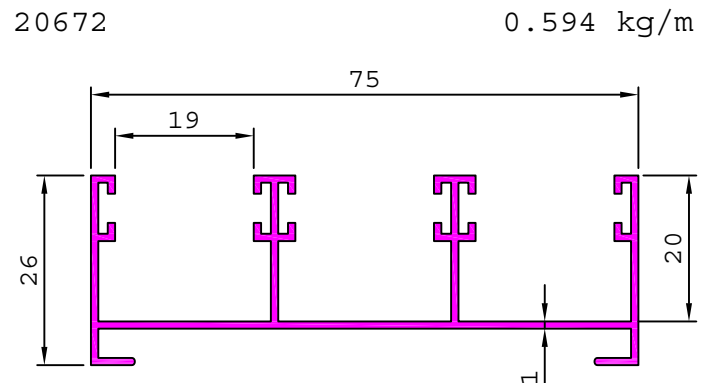
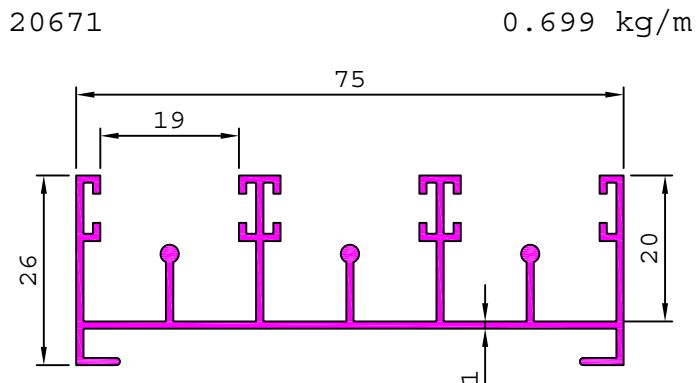
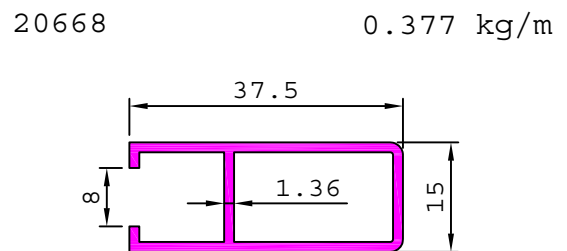

# SUPER PROFILE

## DETAILS OF SLIDING WINDOW SECTIONS

### SERIES - A 15 mm.

### PART II - S/W 5/8"

20669 0.548 kg/m

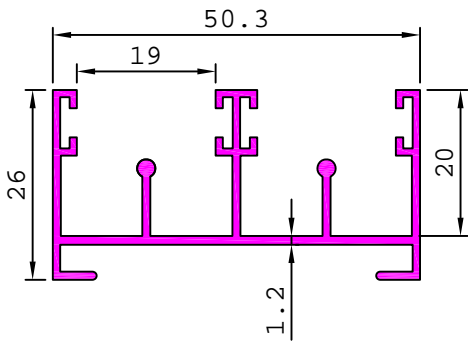

20670 0.432 kg/m

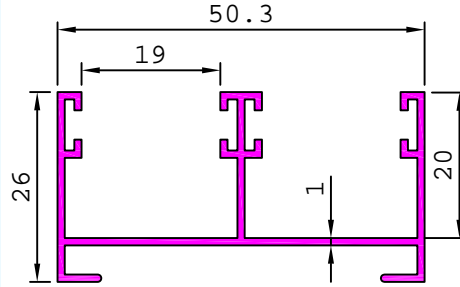

20689 0.481 kg/m

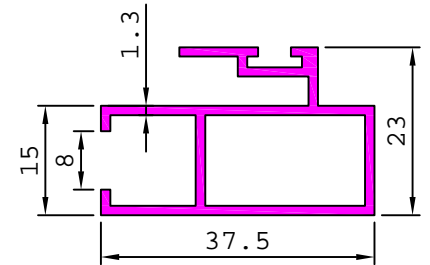

20690 0.366 kg/m

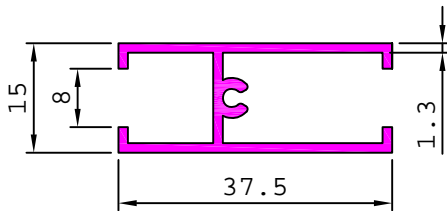

### PART III - S/W 1/2"

20959 0.547 kg/m

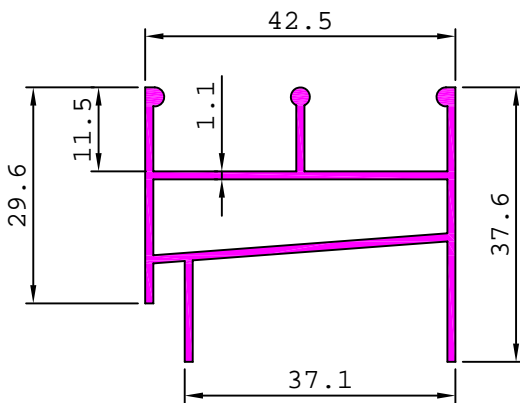

20960 0.329 kg/m

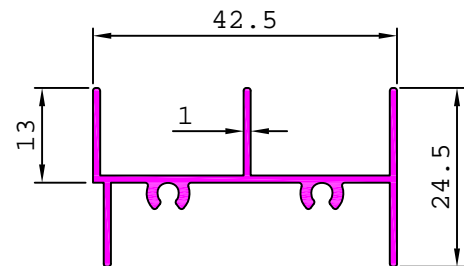

# SUPER PROFILE

## DETAILS OF SLIDING WINDOW SECTIONS

### SERIES - A 15 mm.

### PART III - S/W 1/2"

20688

0.371 kg/m

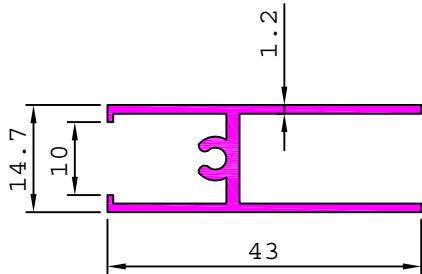

20886

0.411 kg/m

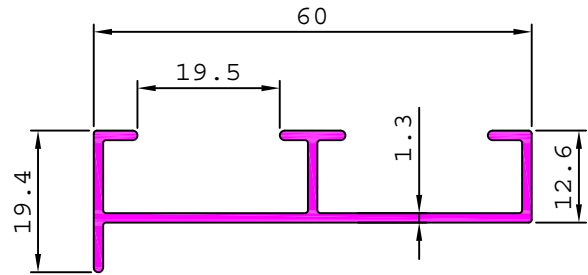

20735

0.793 kg/m

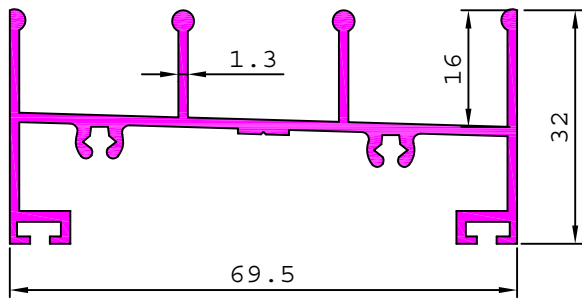

# SUPER PROFILE

## DETAILS OF SLIDING WINDOW SECTIONS SERIES - B (SHUTTER SECTION - 18 mm.)

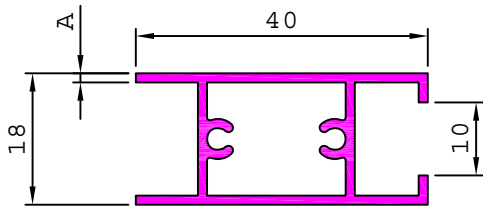

SL. No.	Section No.	A	Weight kg/m
1	20545	0.79	0.289
2	20805	0.91	0.325
3	20604	1.09	0.390
4	20844	1.29	0.456
5	20736	1.55	0.547

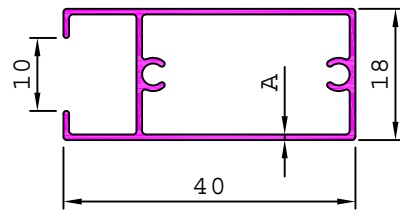

SL. No.	Section No.	A	Weight kg/m
1	20547	0.79	0.289
2	20807	0.91	0.325
3	20606	1.09	0.390
4	20846	1.29	0.456
5	20738	1.55	0.547

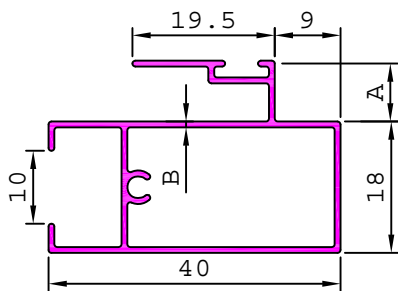

SL. No.	Section No.	A	B	Weight kg/m
1	20546	8.34	0.80	0.346
2	20806	9.00	0.89	0.380
3	20605	9.00	1.00	0.440
4	20845	9.00	1.29	0.547
5	20737	9.00	1.45	0.607

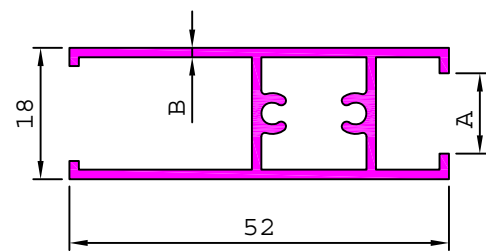

SL. No.	Section No.	A	B	Weight kg/m
1	20811	11.00	0.91	0.390
2	20963	11.00	1.13	0.488
3	20847	10.00	1.29	0.547
4	20652	11.00	1.30	0.547
4	20750	10.00	1.56	0.651

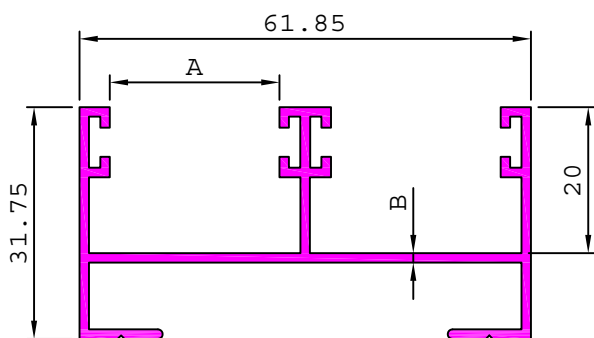

SL. No.	Section No.	A	B	Weight kg/m
1	20812	23.95	0.81	0.441
2	20966	23.85	1.00	0.547
3	20681	23.25	1.30	0.659
4	20829	22.70	1.50	0.784

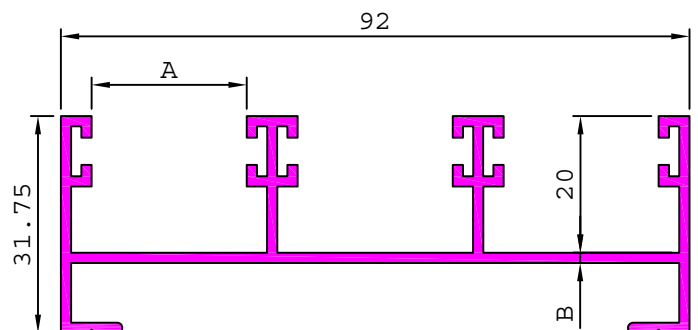

SL. No.	Section No.	A	B	Weight kg/m
1	20816	23.60	0.95	0.683
2	20958	23.60	1.05	0.759
3	20621	23.30	1.30	0.933
4	20831	22.70	1.50	1.060

# SUPER PROFILE

## DETAILS OF SLIDING WINDOW SECTIONS SERIES - B (SHUTTER SECTION - 18 mm.)

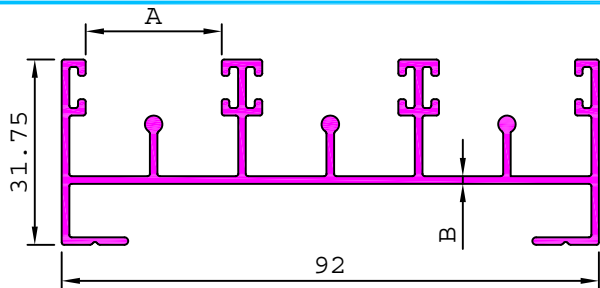

SL. No.	Section No.	A	B	Weight kg/m
1	20815	23.60	0.88	0.739
2	20957	23.60	1.10	0.911
3	20620	23.30	1.30	1.070
4	20832	22.70	1.50	1.248

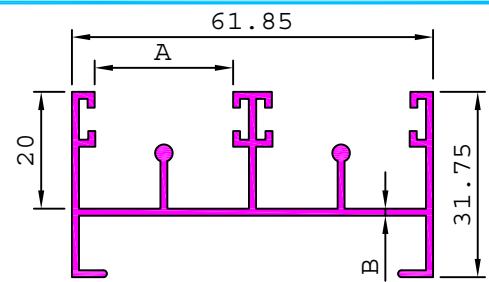

SL. No.	Section No.	A	B	Weight kg/m
1	20813	23.95	0.85	0.497
2	20956	23.85	1.05	0.621
3	20619	23.70	1.20	0.695
4	20830	22.70	1.50	0.909

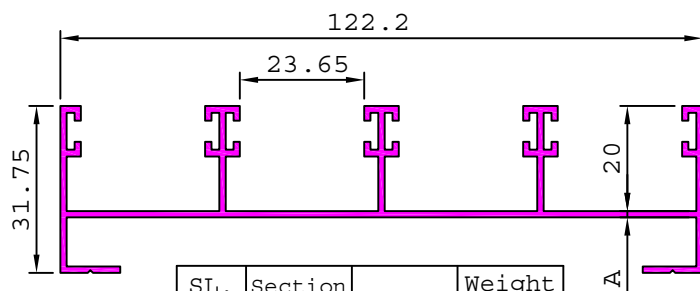
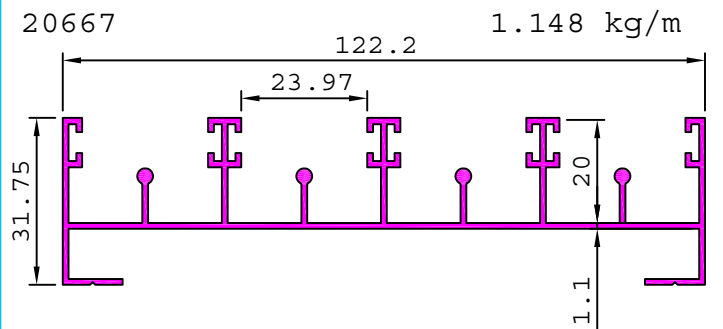
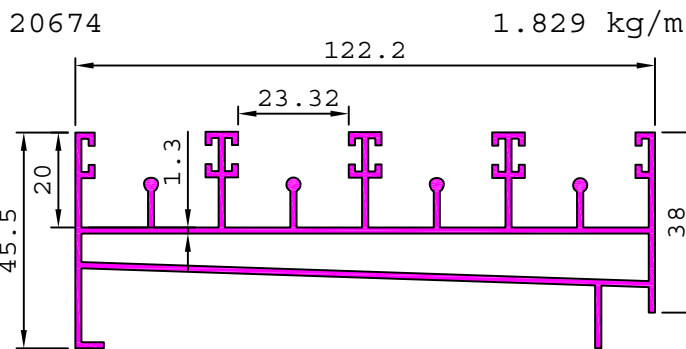

SL. No.	Section No.	A	Weight kg/m
1	20817	1.10	0.976
2	20666	1.20	1.093

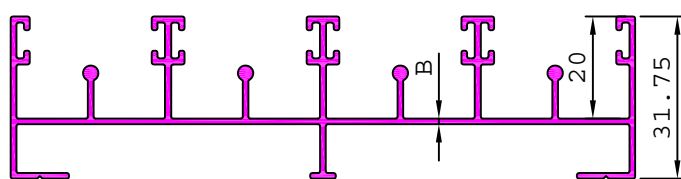
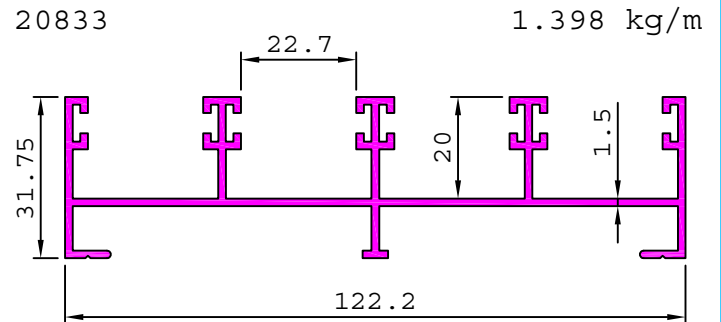

SL. No.	Section No.	A	B	Weight kg/m
1	20818	23.90	1.00	1.093
2	20706	23.90	1.10	1.205
3	20834	22.70	1.50	1.648

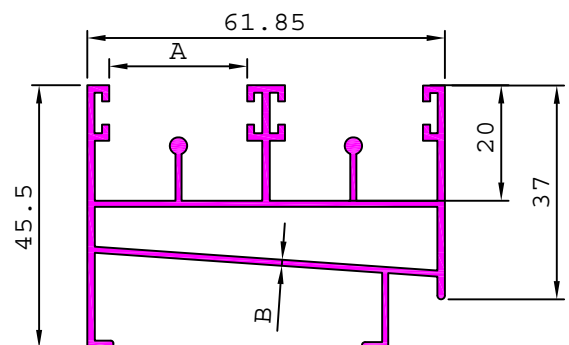

SL. No.	Section No.	A	B	Weight kg/m
1	20965	23.85	1.05	0.882
2	20657	23.45	1.30	1.055

# SUPER PROFILE

## DETAILS OF SLIDING WINDOW SECTIONS SERIES - B (SHUTTER SECTION - 18 mm.)

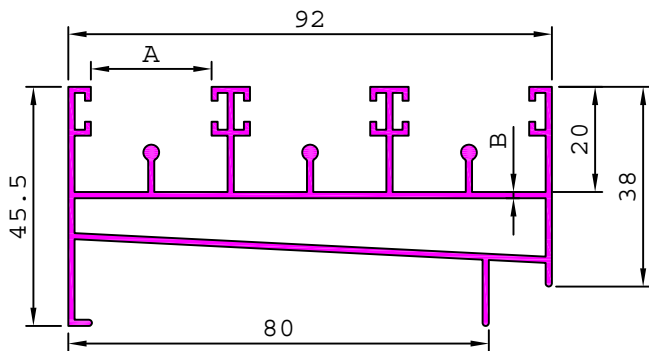

20635

1.130 kg/m

SL. No.	Section No.	A	B	Weight kg/m
1	20814	22.95	1.18	1.302
2	21031	22.95	1.30	1.441
3	20617	22.70	1.50	1.659

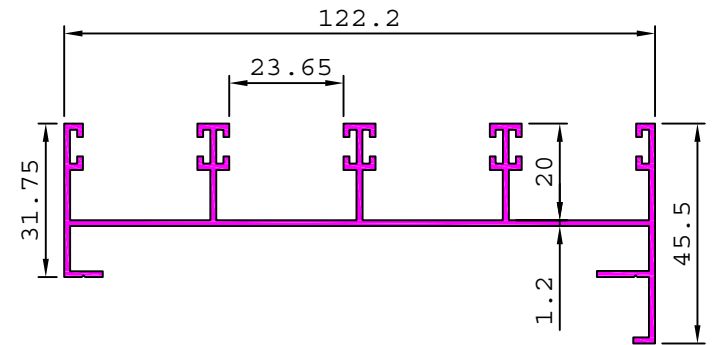

20920 0.503 kg/m

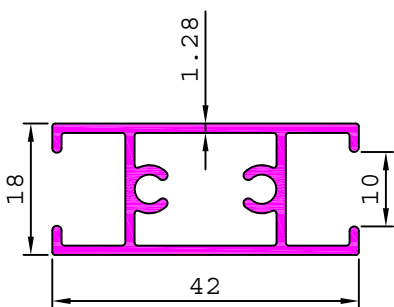

20839 0.492 kg/m

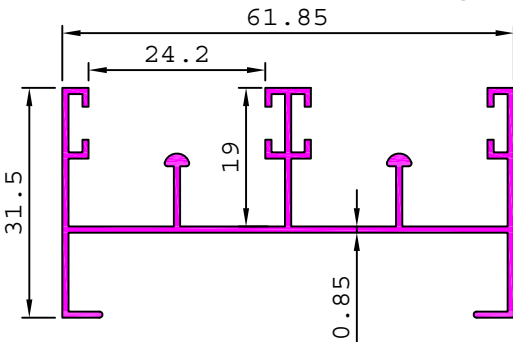

20645 1.690 kg/m

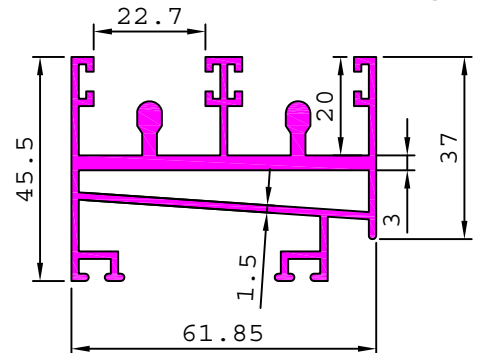

20636 1.388 kg/m

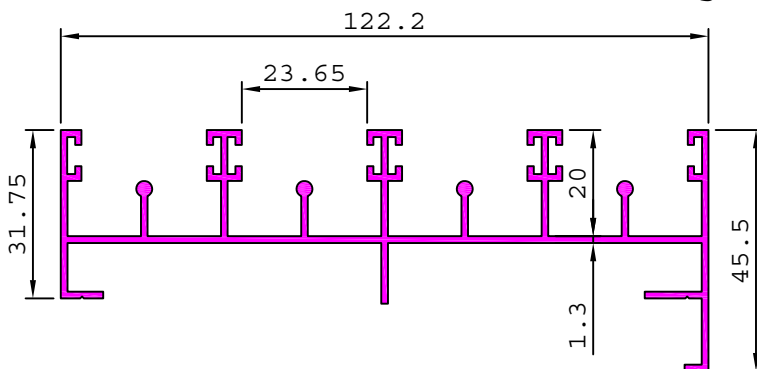

20702 1.284 kg/m

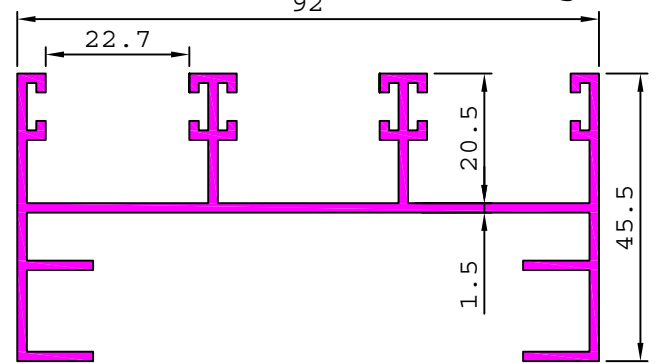

20684 0.547 kg/m

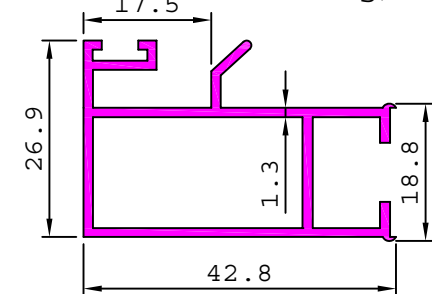

20685 0.463 kg/m

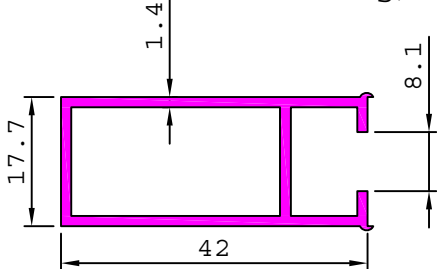

20686 0.558 kg/m

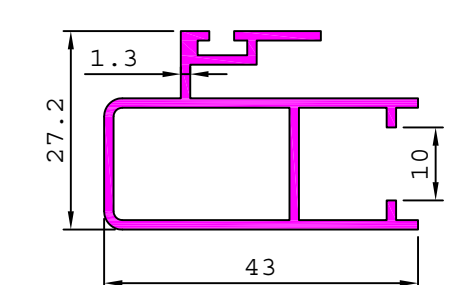



# SUPER PROFILE

## DETAILS OF SLIDING WINDOW SECTIONS SERIES - B (SHUTTER SECTION - 18 mm.)

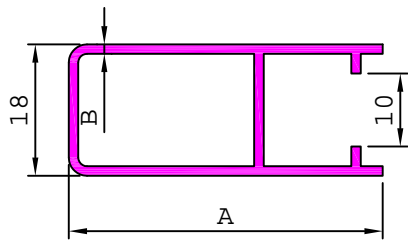

SL. No.	Section No.	A	B	Weight kg/m
1	20687	43.00	1.30	0.424
2	20887	52.00	1.48	0.548

20739 0.909 kg/m

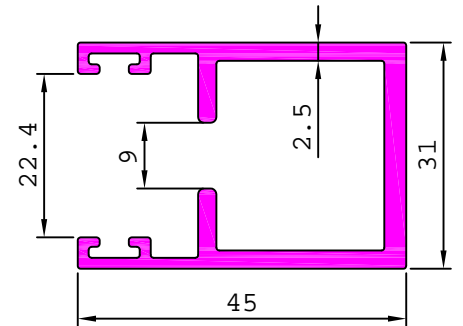

20791 0.466 kg/m

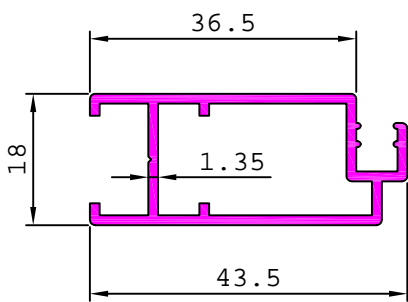

20802 0.520 kg/m

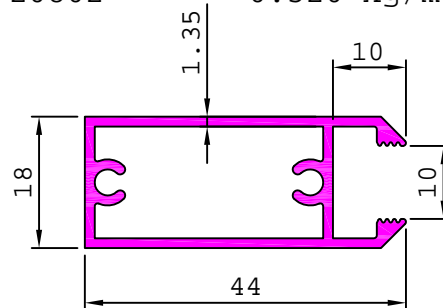

20803 0.598 kg/m

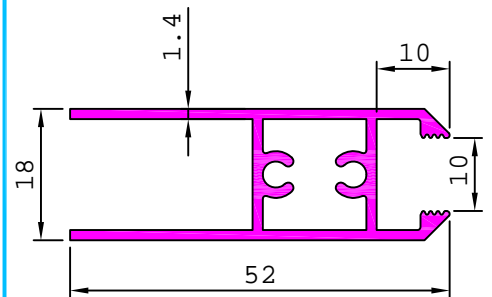

20804 0.626 kg/m

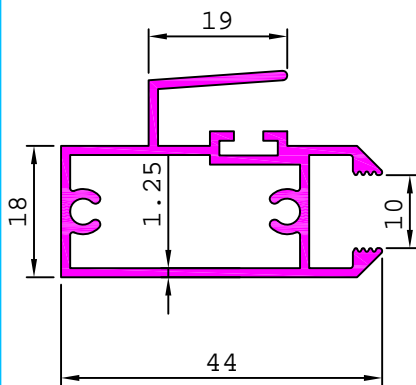

20882 0.527 kg/m

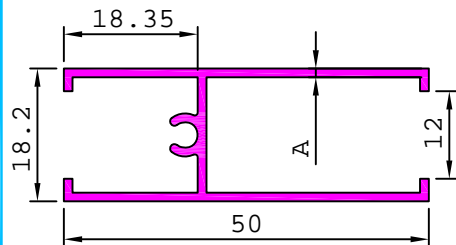

SL. No.	Section No.	A	Weight kg/m
1	20858	1.20	0.427
2	20876	1.34	0.471

20888 1.005 kg/m

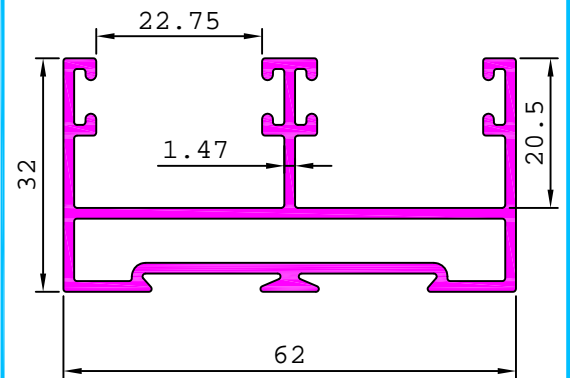

20866 0.173 kg/m

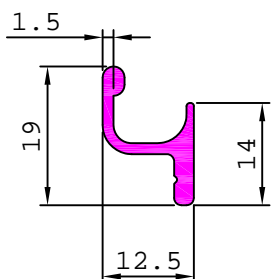

20892 0.527 kg/m

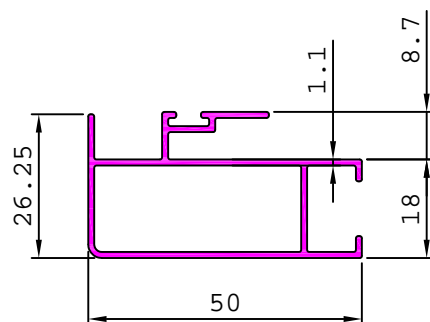

21051 1.106 kg/m

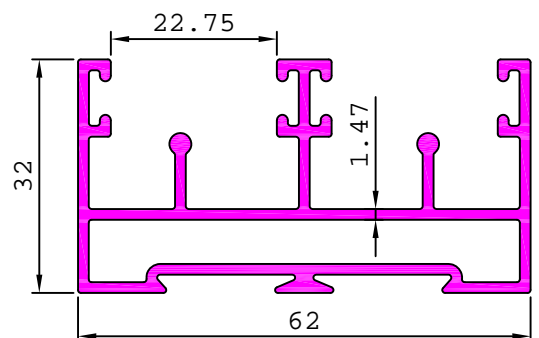

# SUPER PROFILE

## DETAILS OF SLIDING WINDOW SECTIONS SERIES - B (SHUTTER SECTION - 18 mm.)

20924 0.683 kg/m

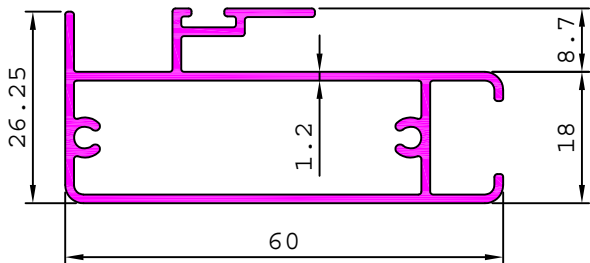

20925 0.549 kg/m

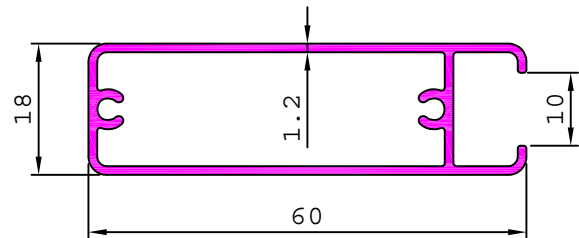

20926 0.641 kg/m

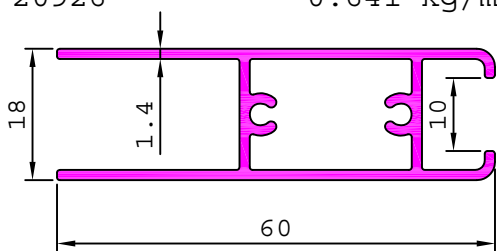

20893 0.434 kg/m

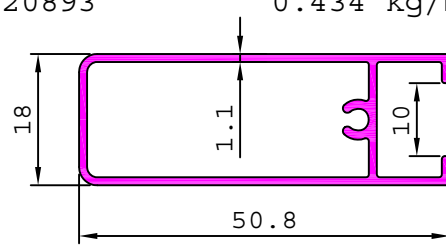

20576 0.663 kg/m

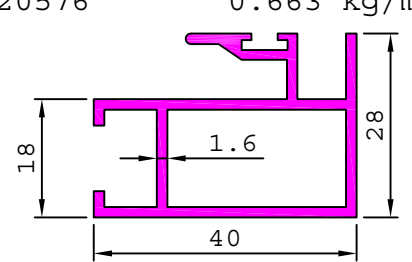

20532 0.304 kg/m

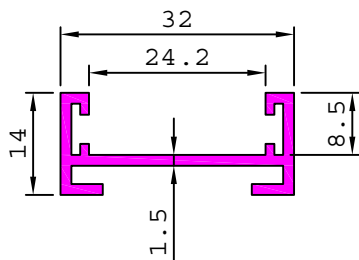

20567 0.601 kg/m

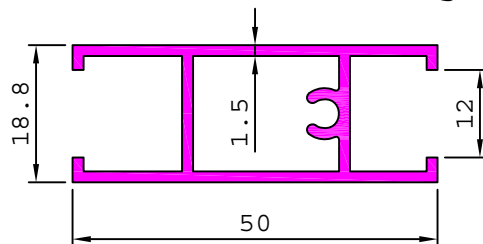

20577 0.522 kg/m

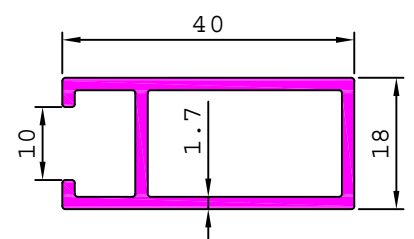

21028 1.792 kg/m

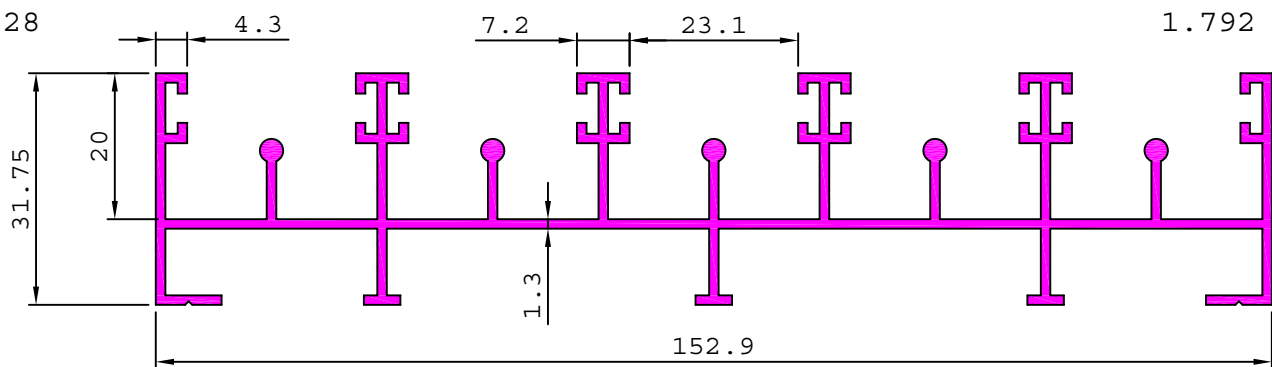

21029 1.523 kg/m

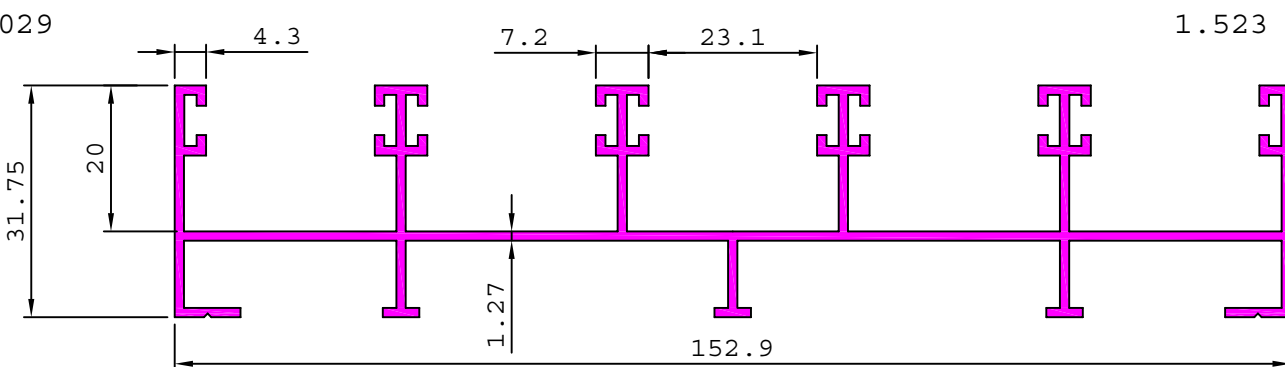

# SUPER PROFILE

## DETAILS OF SLIDING WINDOW SECTIONS SERIES - B (SHUTTER SECTION - 18 mm.)

20603

1.141 kg/m

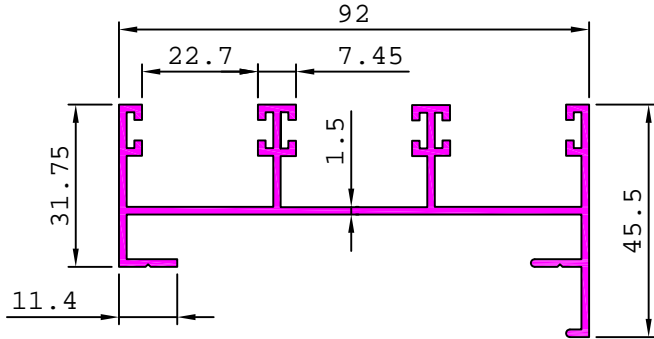

21302

0.457 kg/m

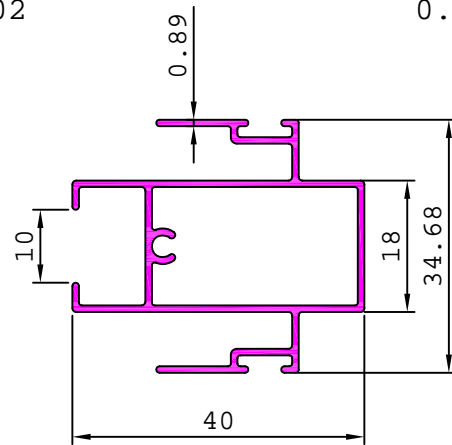

21303

0.586 kg/m

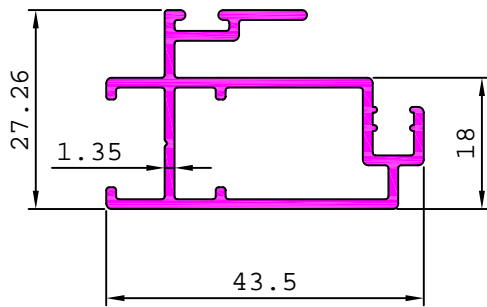

# SUPER PROFILE

## DETAILS OF SLIDING WINDOW SECTIONS

### SERIES - C (SHUTTER SECTION - 20 mm.) PART I - IV

<p>20529      0.642 kg/m</p>	<p>20530      0.571 kg/m</p>	<p>20531      0.697 kg/m</p>
------------------------------	------------------------------	------------------------------

### PART - II

<p>20544      0.495 kg/m</p>	<p>20566      0.693 kg/m</p>
<p>20567      0.601 kg/m</p>	<p>20840      0.594 kg/m</p>

### PART - III

<p>20694      0.695 kg/m</p>	<p>20695      1.088 kg/m</p>
------------------------------	------------------------------

## DETAILS OF SLIDING WINDOW SECTIONS

### PART - III

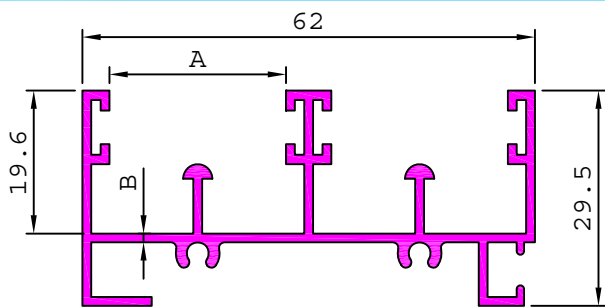

SL. No.	Section No.	A	B	Weight kg/m
1	21053	24.20	1.00	0.630
2	20703	24.20	1.20	0.726
3	21139	23.30	1.50	0.902

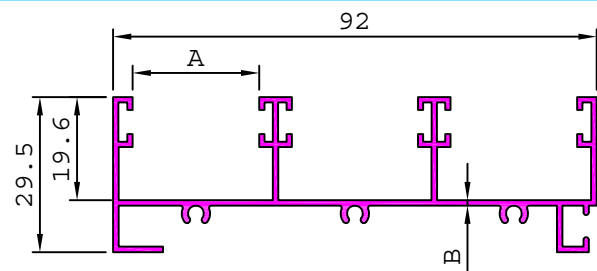

SL. No.	Section No.	A	B	Weight kg/m
1	21054	24.10	1.05	0.777
2	20696	24.10	1.20	0.907
3	20978	23.20	1.40	1.066
4	21137	23.20	1.50	1.102
4	21100	23.05	2.00	1.342

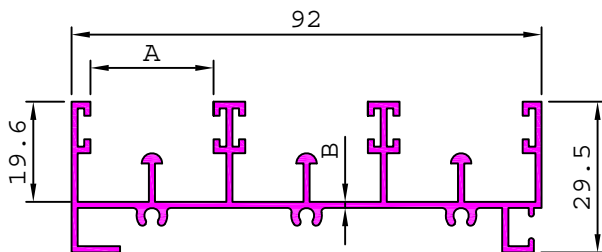

SL. No.	Section No.	A	B	Weight kg/m
1	21055	24.10	1.00	0.866
2	20704	24.10	1.20	1.005
3	20977	23.20	1.45	1.217
4	21099	23.05	2.00	1.516

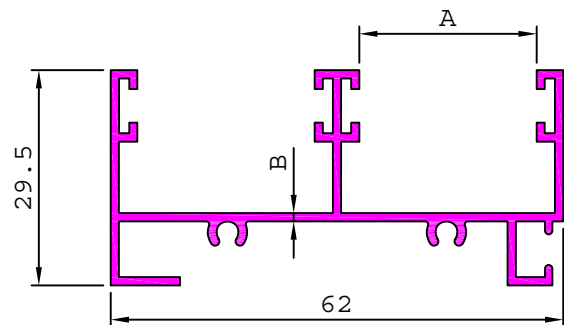

SL. No.	Section No.	A	B	Weight kg/m
1	20987	24.30	1.13	0.615
2	21138	23.30	1.50	0.807

### PART - IV

20697 1.374 kg/m

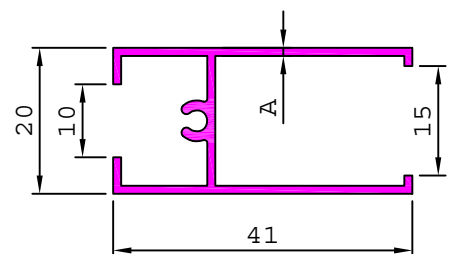
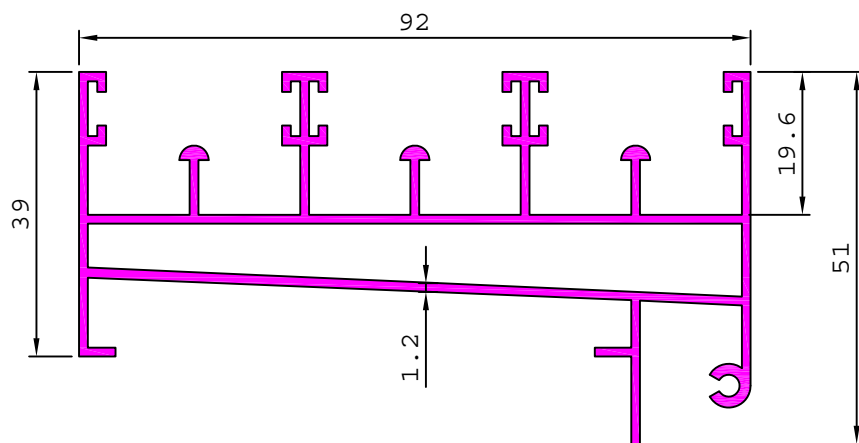

SL. No.	Section No.	A	Weight kg/m
1	20988	0.98	0.314
2	20710	1.10	0.355
3	21092	2.00	0.606

## DETAILS OF SLIDING WINDOW SECTIONS

### PART - IV

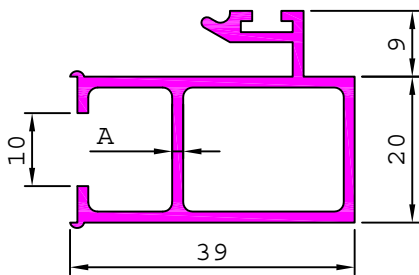

SL. No.	Section No.	A	Weight kg/m
1	21052	1.00	0.409
2	20976	1.15	0.473
3	20708	1.50	0.605
4	21094	2.00	0.734

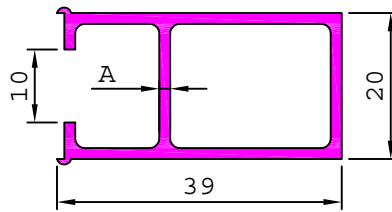

SL. No.	Section No.	A	Weight kg/m
1	20968	0.80	0.277
2	20931	1.00	0.342
3	20975	1.25	0.418
4	20709	1.50	0.488
5	21093	2.00	0.634

20551 0.484 kg/m

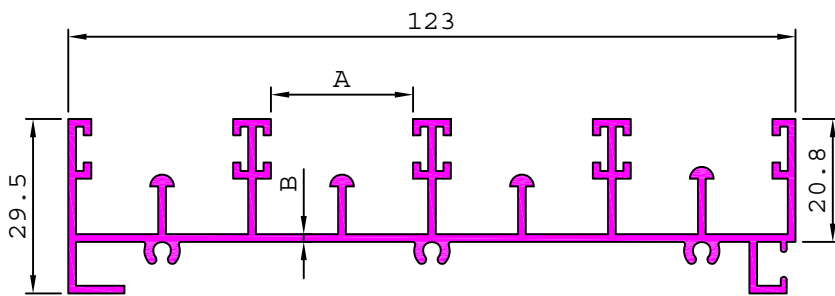
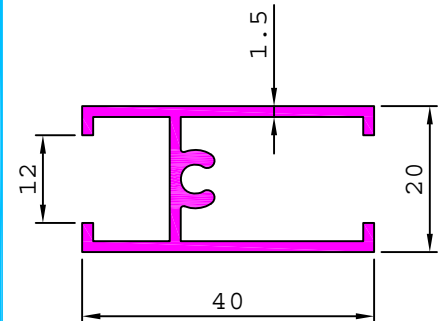

SL. No.	Section No.	A	B	Weight kg/m
1	20910	24.00	1.30	1.394
2	21101	23.30	2.00	1.915

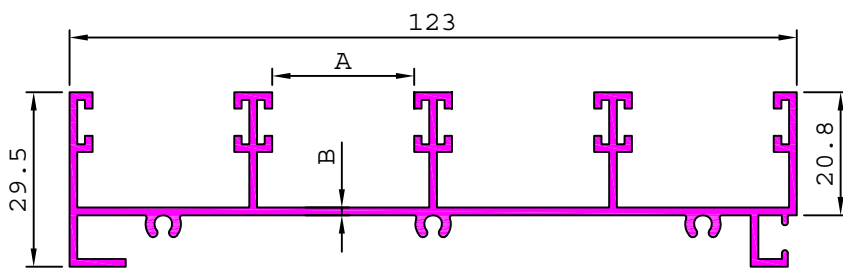

SL. No.	Section No.	A	B	Weight kg/m
1	20911	24.00	1.30	1.207
2	21098	23.30	2.00	1.670

21022 0.539 kg/m

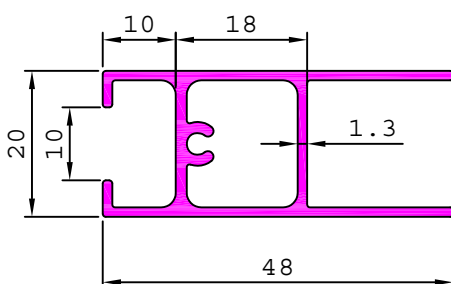

21216 1.233 kg/m

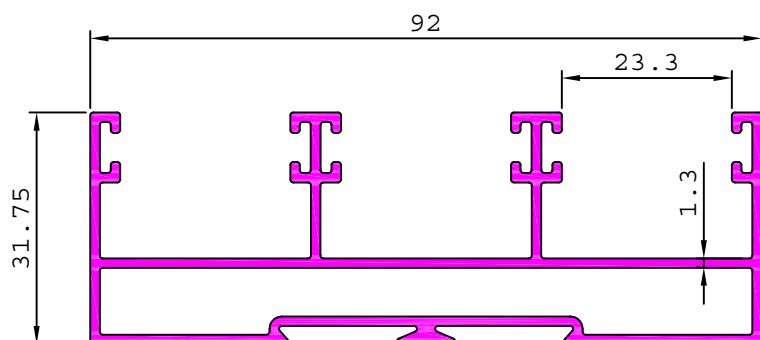

## DETAILS OF SLIDING WINDOW SECTIONS

### PART - IV

20972

0.451 kg/m

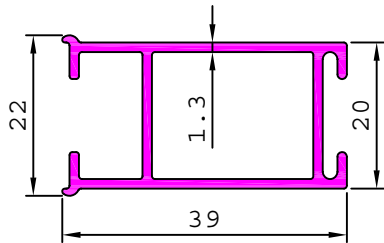

20973

0.503 kg/m

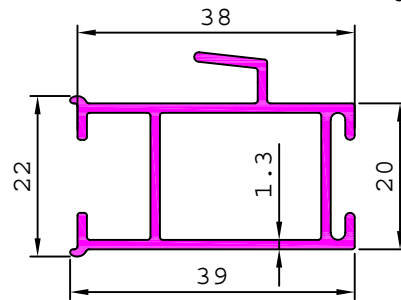

21283

0.512 kg/m

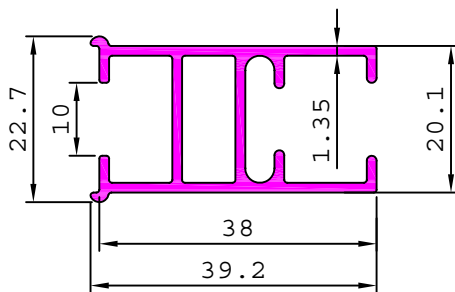

21320

0.477 kg/m

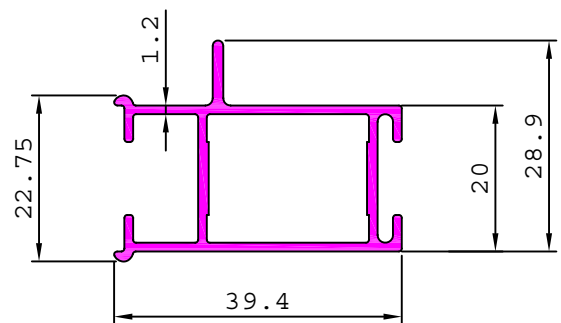

# SUPER PROFILE

## DETAILS OF SLIDING WINDOW SECTIONS SERIES - D (SHUTTER SECTION - 25 mm.) PART I

20506 0.717 kg/m

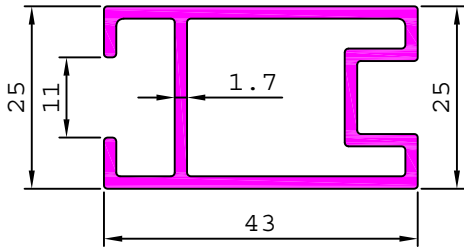

20507 0.642 kg/m

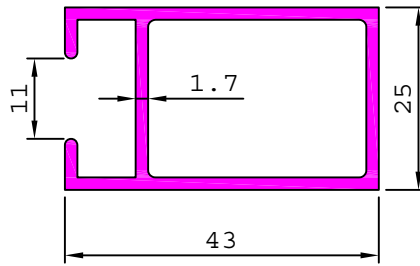

20516 0.560 kg/m

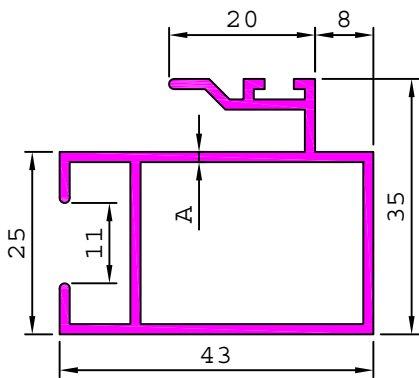
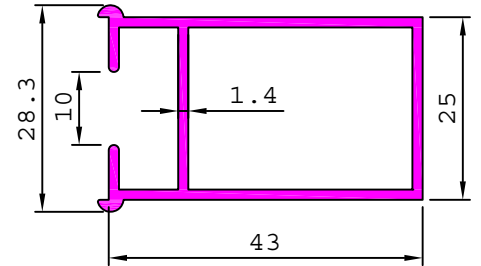

SL. No.	Section No.	A	Weight kg/m
1	20939	1.40	0.678
2	20508	1.70	0.802

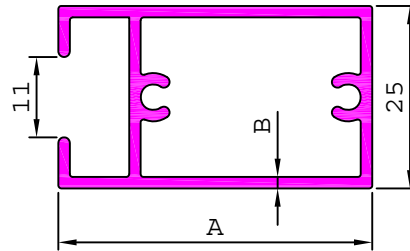

SL. No.	Section No.	A	B	Weight kg/m
1	20841	43.00	1.33	0.569
2	20602	43.00	1.57	0.665
3	21030	43.00	1.98	0.828
4	21253	50.00	1.00	0.483
5	20707	50.00	1.20	0.593
6	21056	50.00	1.51	0.717

20517 0.708 kg/m

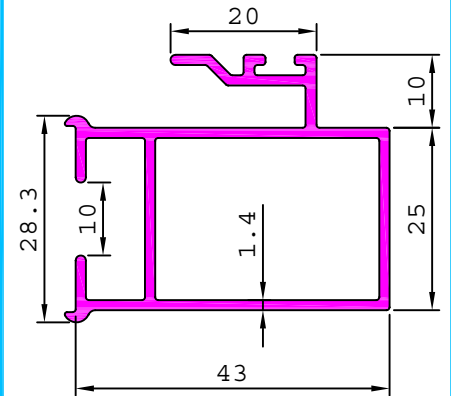

20518 0.675 kg/m

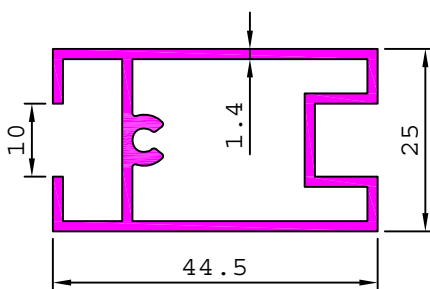

20675 0.274 kg/m

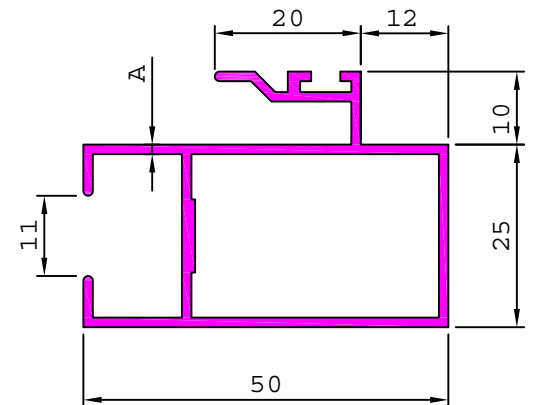
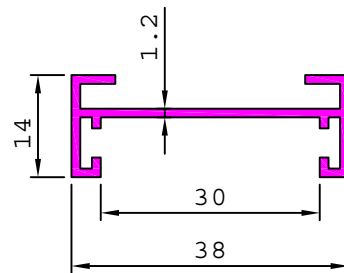

20633 0.676 kg/m

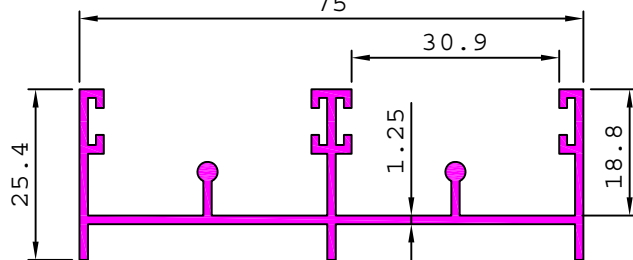

SL. No.	Section No.	A	Weight kg/m
1	20741	1.30	0.683
2	21091	1.48	0.776



## DETAILS OF SLIDING WINDOW SECTIONS SERIES - D (SHUTTER SECTION - 25 mm.) PART I

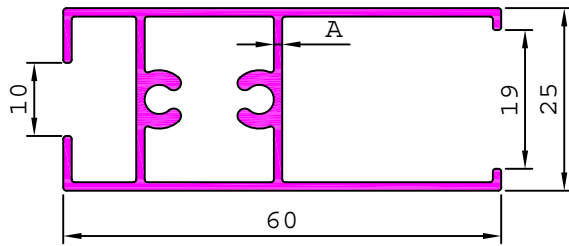

SL. No.	Section No.	A	Weight kg/m
1	20639	1.15	0.672
2	20842	1.45	0.781

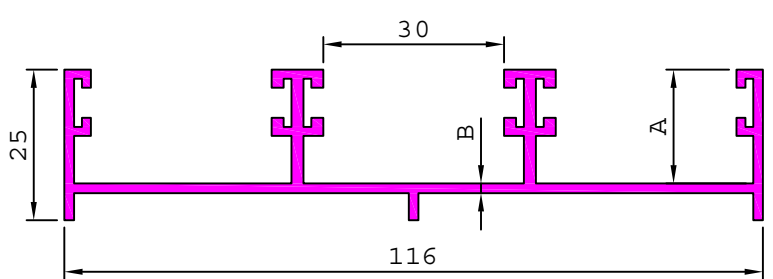
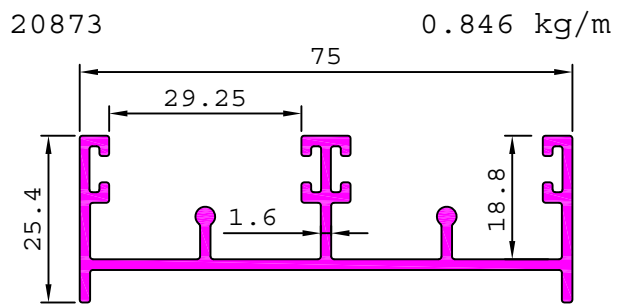
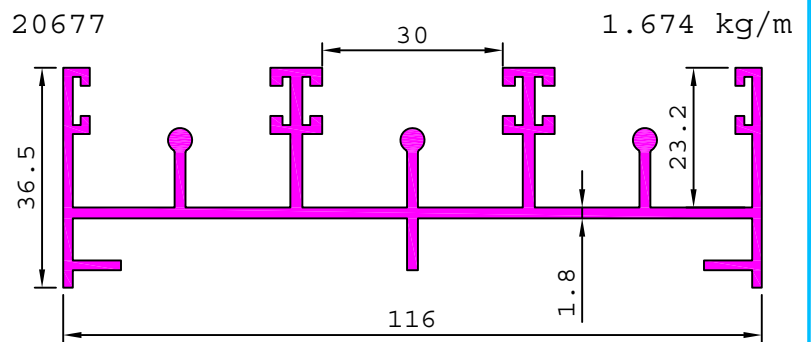
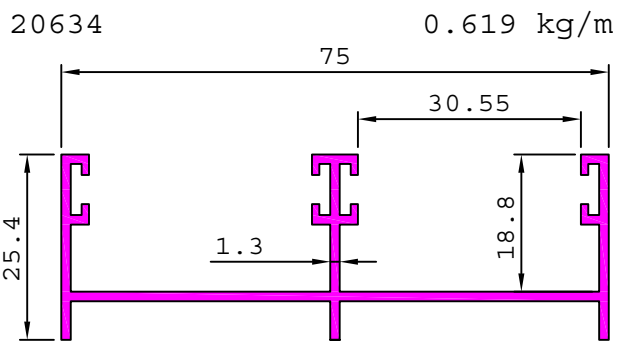

SL. No.	Section No.	A	B	Weight kg/m
1	21032	19.10	1.40	1.005
2	20678	18.90	1.60	1.194

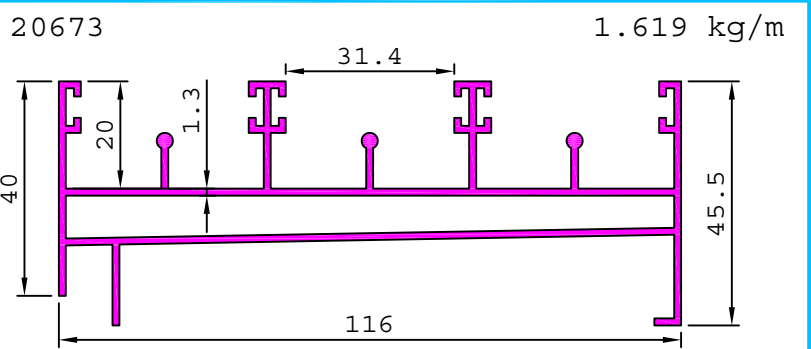
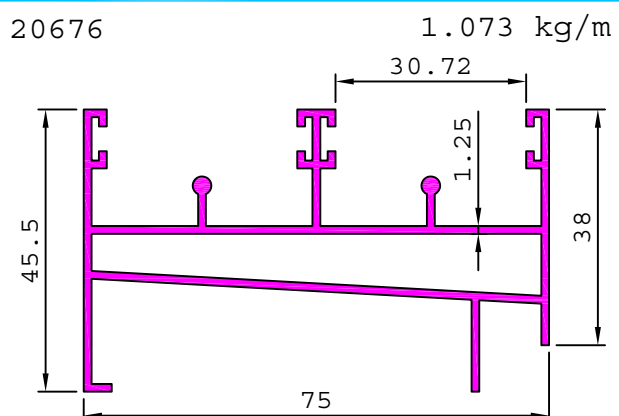
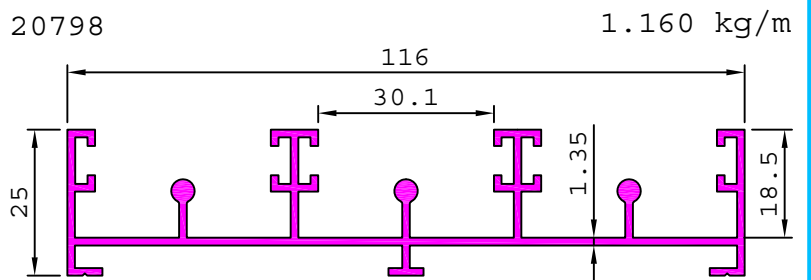
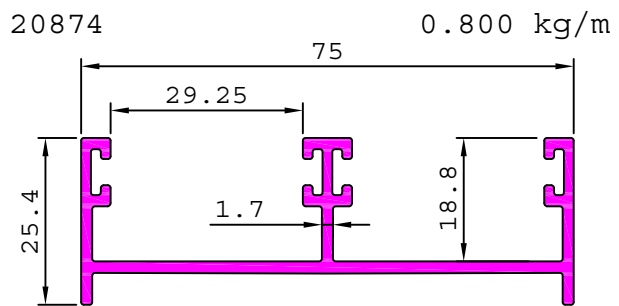

# SUPER PROFILE

## DETAILS OF SLIDING WINDOW SECTIONS SERIES - D (SHUTTER SECTION - 25 mm.) PART I

20796

1.434 kg/m

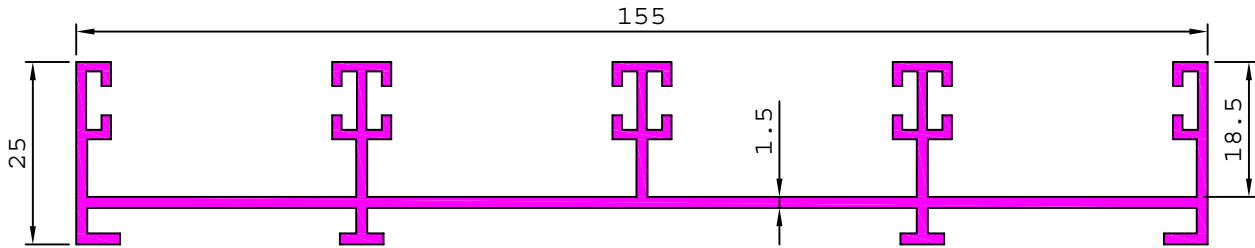

20797

1.667 kg/m

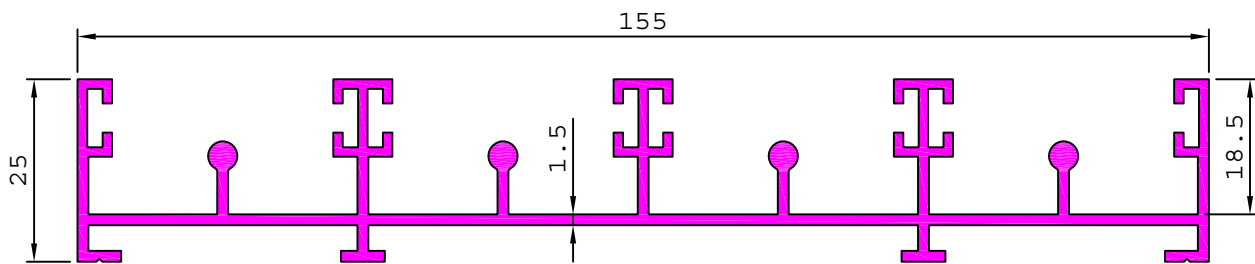

## SERIES - D (SHUTTER SECTION - 25 mm.) PART II

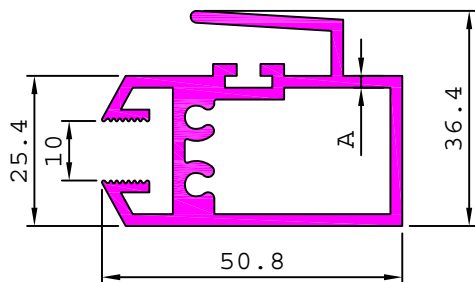

SL. No.	Section No.	A	Weight kg/m
1	21145	1.50	0.985
2	20711	1.68	1.090

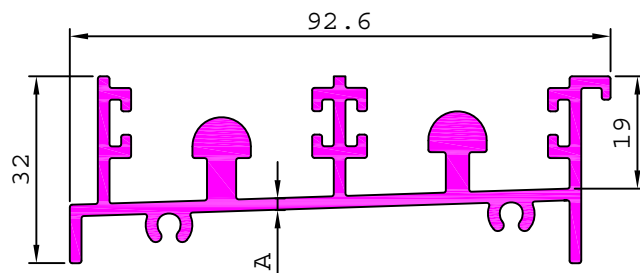

SL. No.	Section No.	A	B	Weight kg/m
1	21146	32.15	1.50	1.308
2	20712	31.00	2.00	1.805

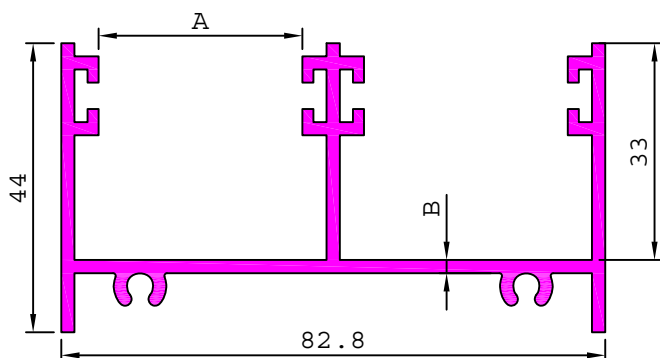

SL. No.	Section No.	A	B	Weight kg/m
1	21147	32.15	1.50	1.073
2	20713	31.00	2.00	1.429

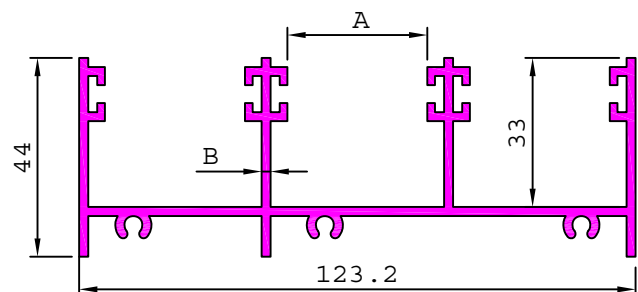

SL. No.	Section No.	A	B	Weight kg/m
1	21149	32.10	1.50	1.539
2	20714	31.00	2.00	2.062

# SUPER PROFILE

## DETAILS OF SLIDING WINDOW SECTIONS SERIES - D (SHUTTER SECTION - 25 mm.) PART II

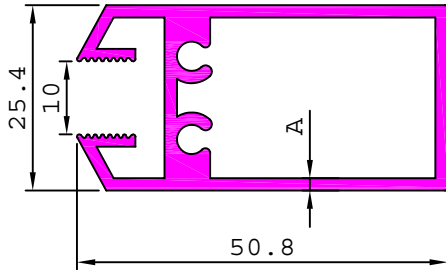

SL. No.	Section No.	A	Weight kg/m
1	21144	1.50	0.797
2	20715	1.70	0.879

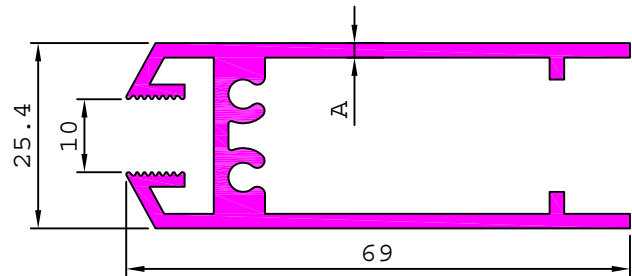

SL. No.	Section No.	A	Weight kg/m
1	21143	1.50	0.882
2	20716	2.00	1.119

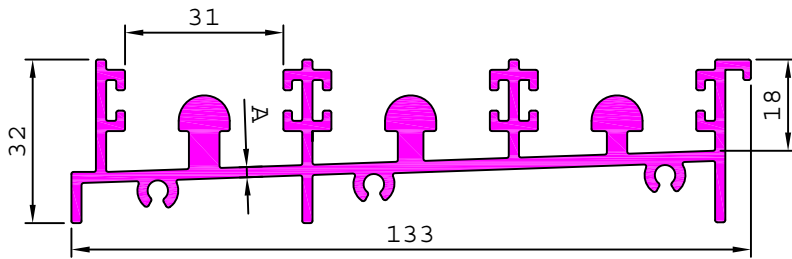

SL. No.	Section No.	A	Weight kg/m
1	21148	1.50	1.842
2	20717	2.00	2.572

20801 1.237 kg/m

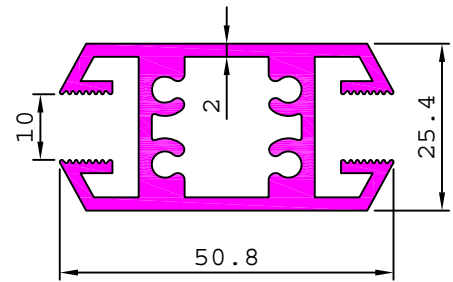

20528 0.781 kg/m

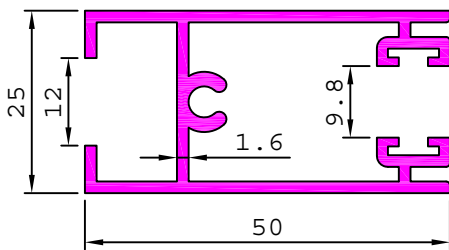

20543 0.669 kg/m

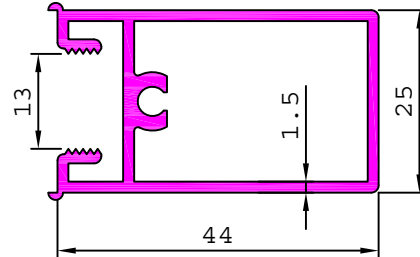

20921 0.584 kg/m

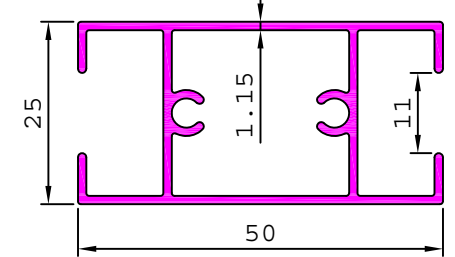

20732 0.669 kg/m

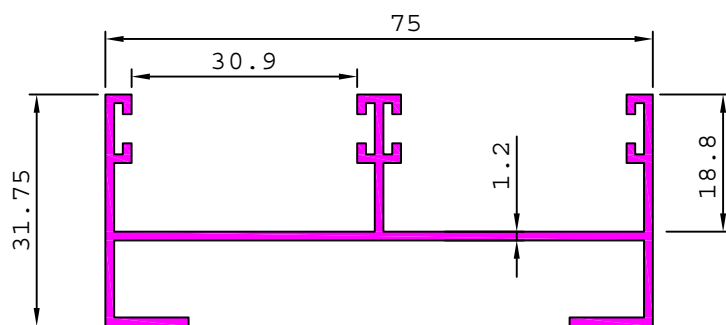

20740 1.006 kg/m

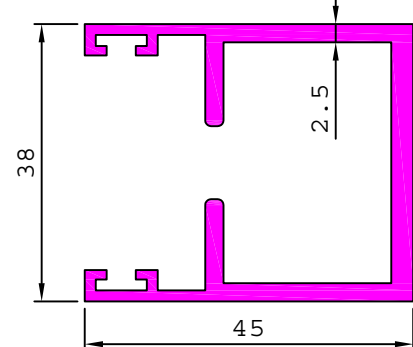

# SUPER PROFILE

## DETAILS OF SLIDING WINDOW SECTIONS SERIES - D (SHUTTER SECTION - 25 mm.) PART II

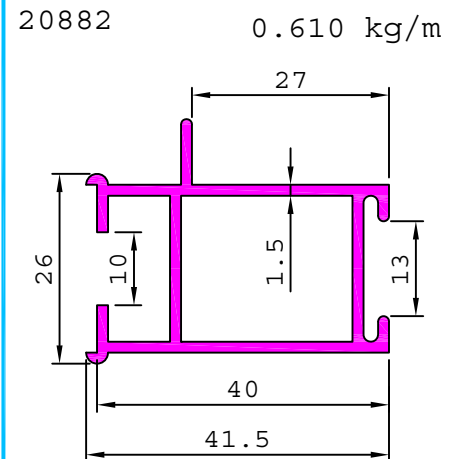
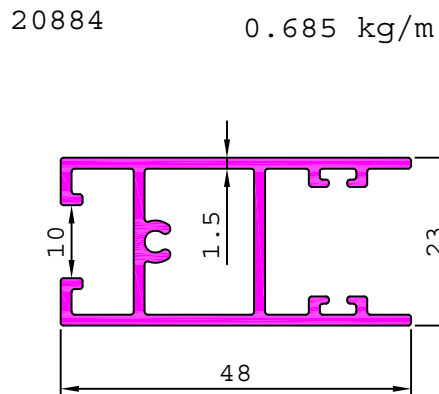
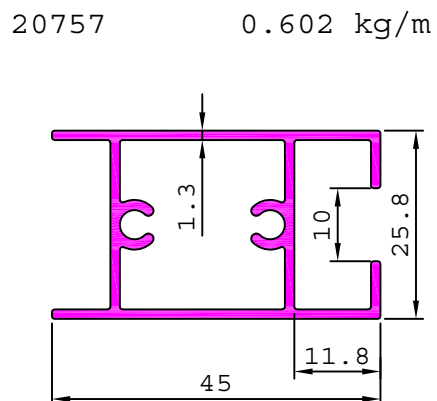
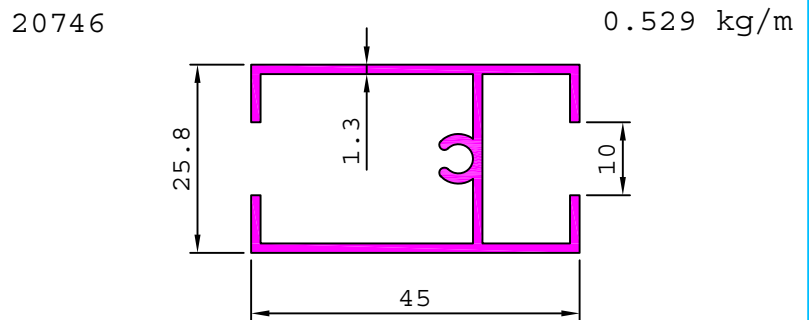
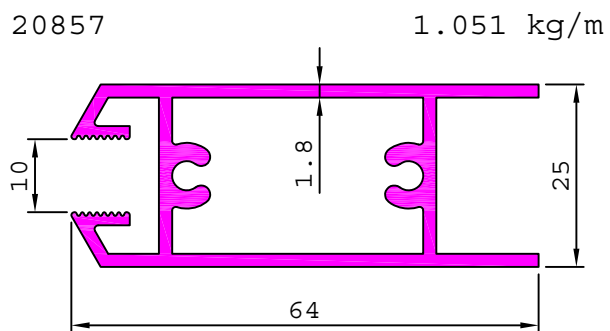
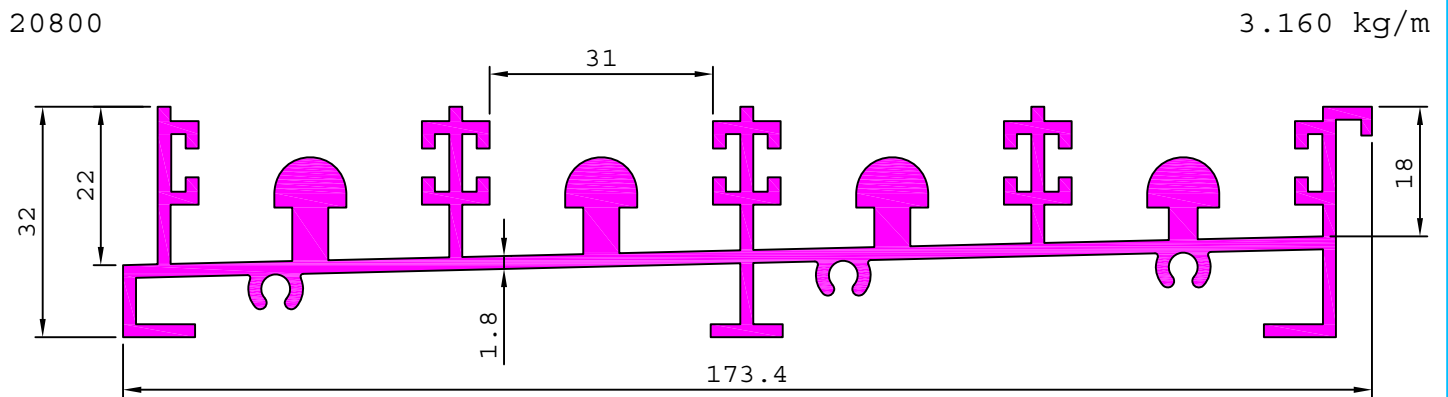
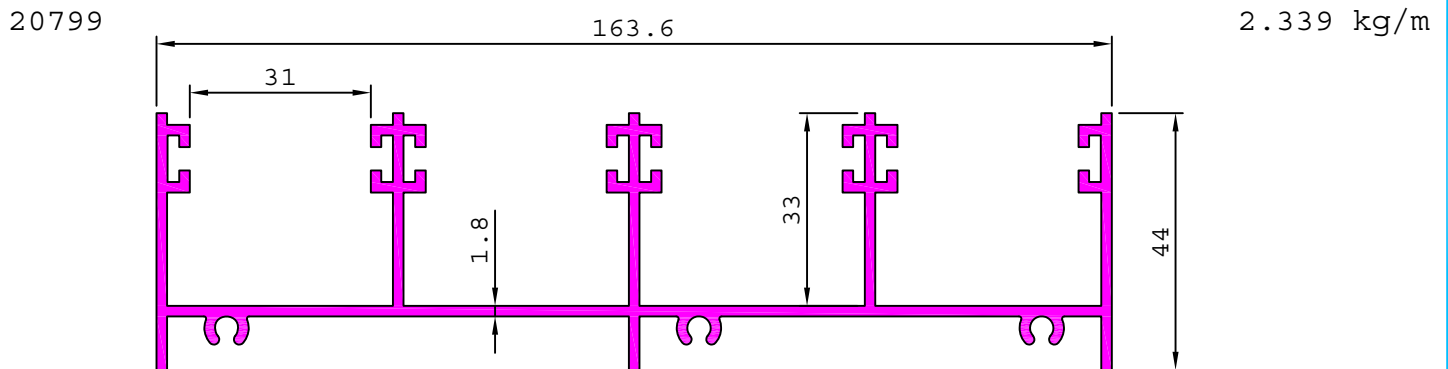

# SUPER PROFILE

## DETAILS OF SLIDING WINDOW SECTIONS SERIES - D (SHUTTER SECTION - 25 mm.) PART II

20922 0.925 kg/m

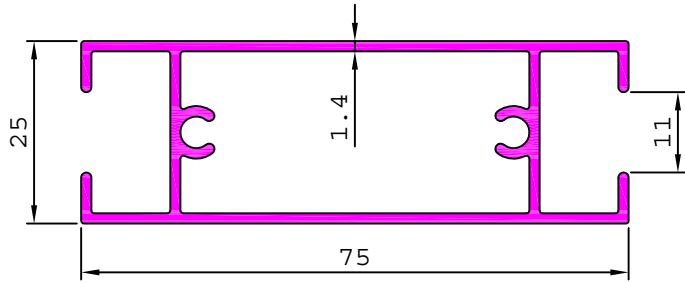

20923 0.895 kg/m

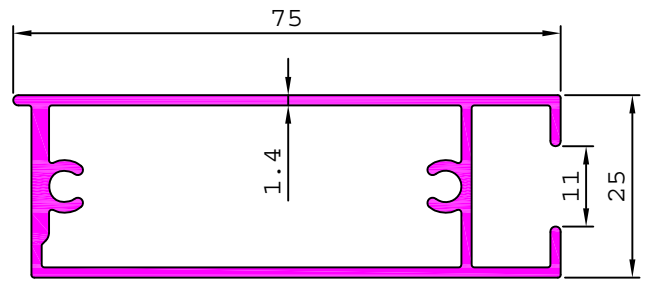

21045 0.475 kg/m

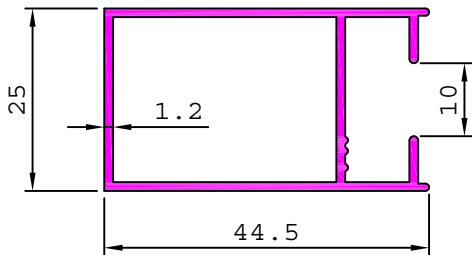

21046 0.595 kg/m

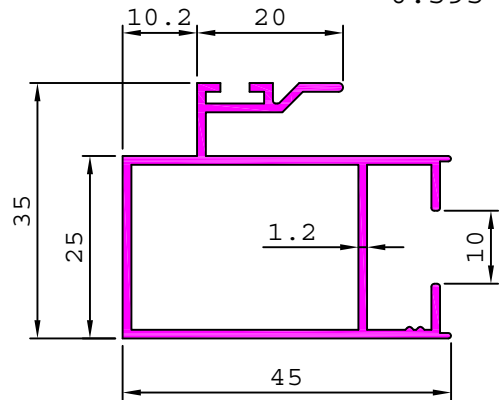

21304 1.082 kg/m

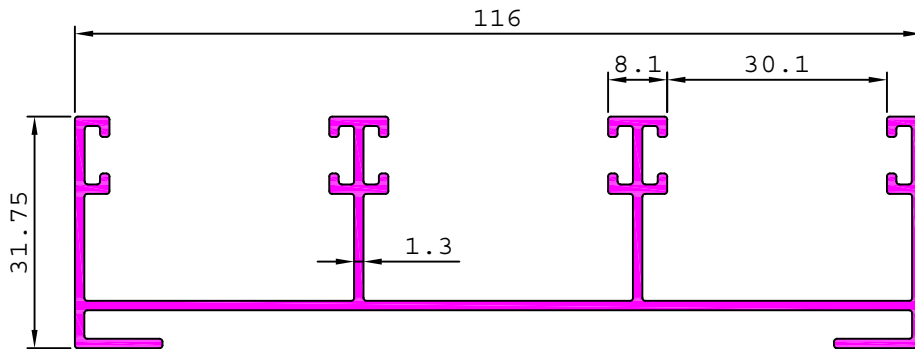

21308 0.657 kg/m

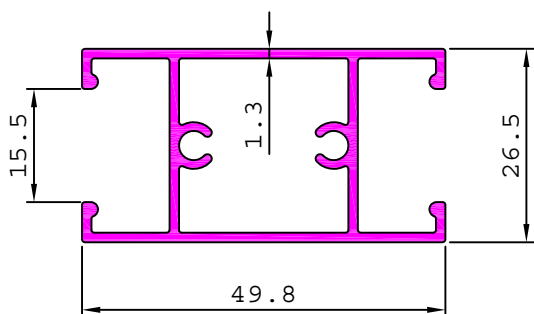

21309 0.767 kg/m

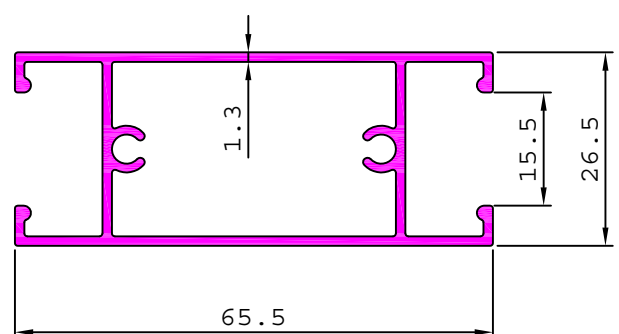

## DETAILS OF SLIDING WINDOW SECTIONS SERIES - D (SHUTTER SECTION - 25 mm.) PART II

21321

2.329 kg/m

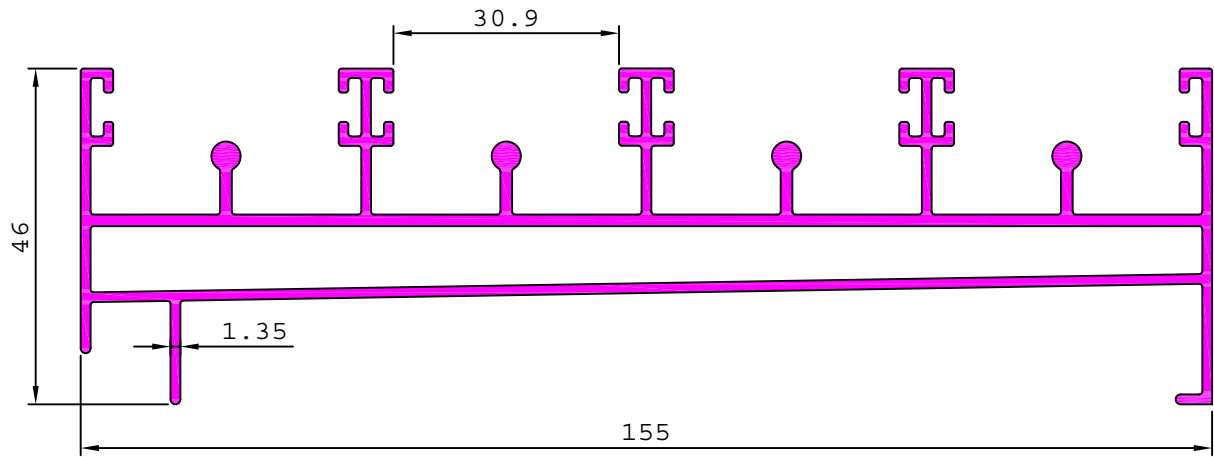

# SUPER PROFILE

## DETAILS OF SLIDING WINDOW SECTIONS SERIES - E (SHUTTER SECTION - 30 mm.)

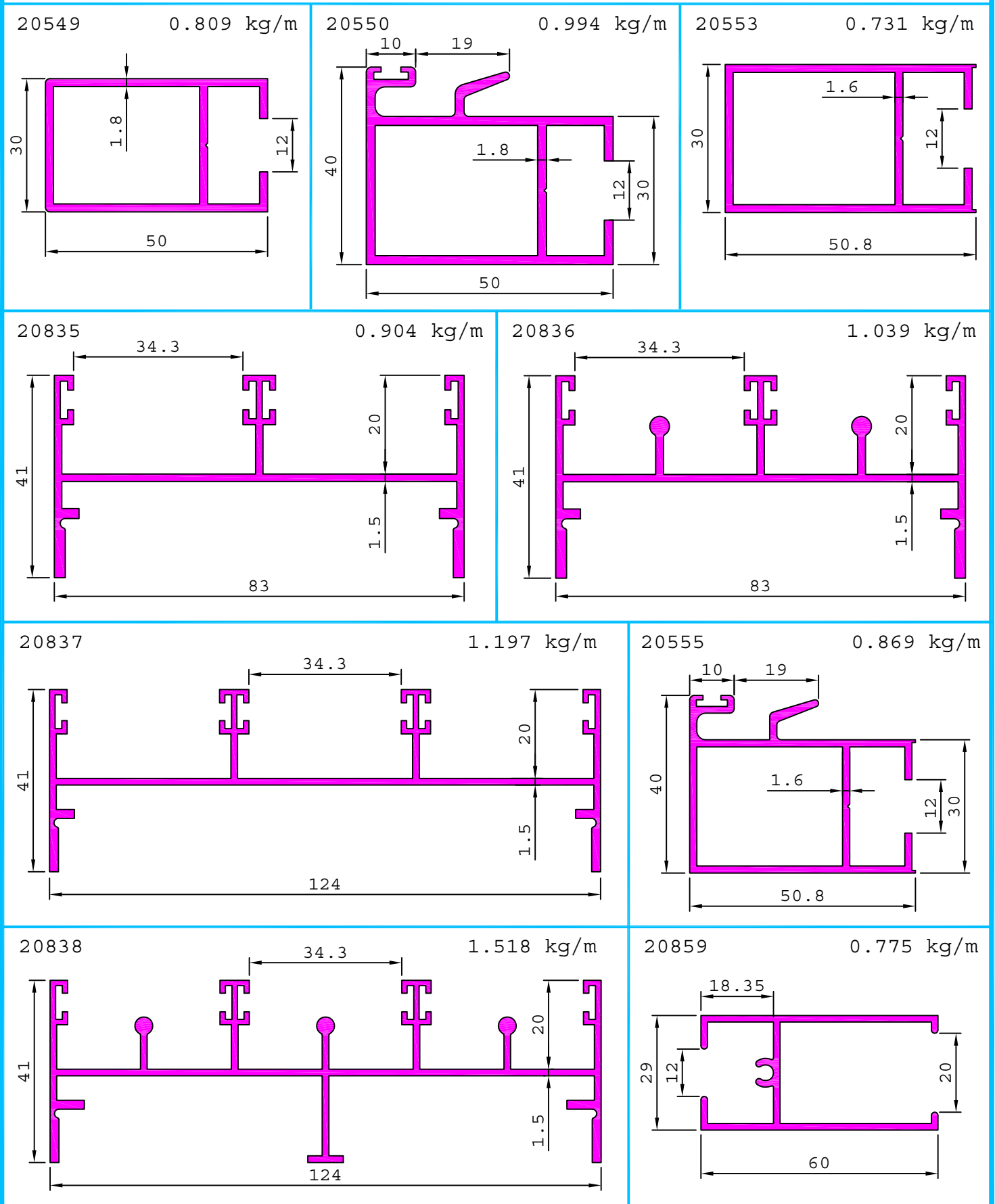

# SUPER PROFILE

## DETAILS OF SLIDING WINDOW SECTIONS SERIES - E (SHUTTER SECTION - 30 mm.)

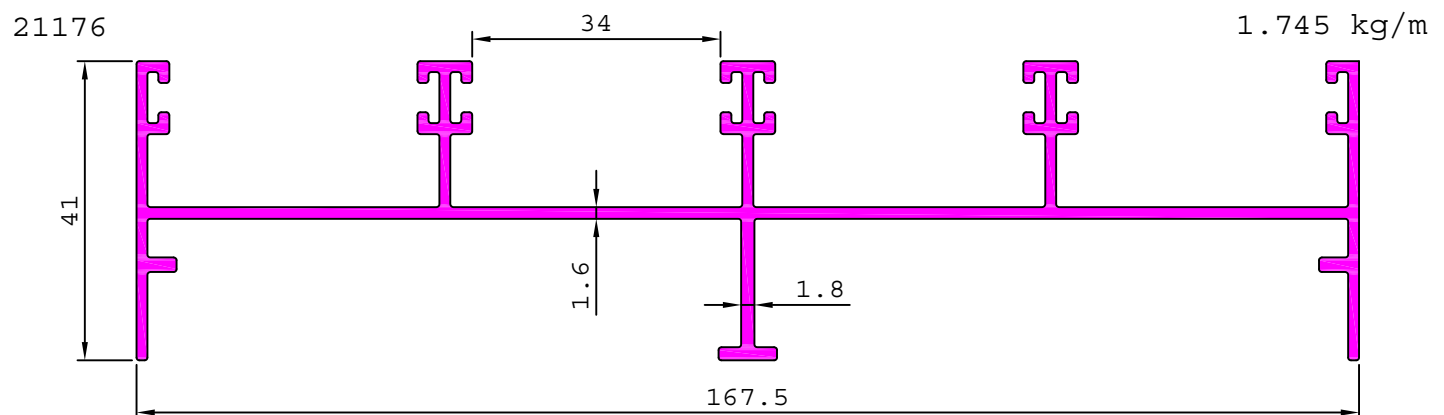
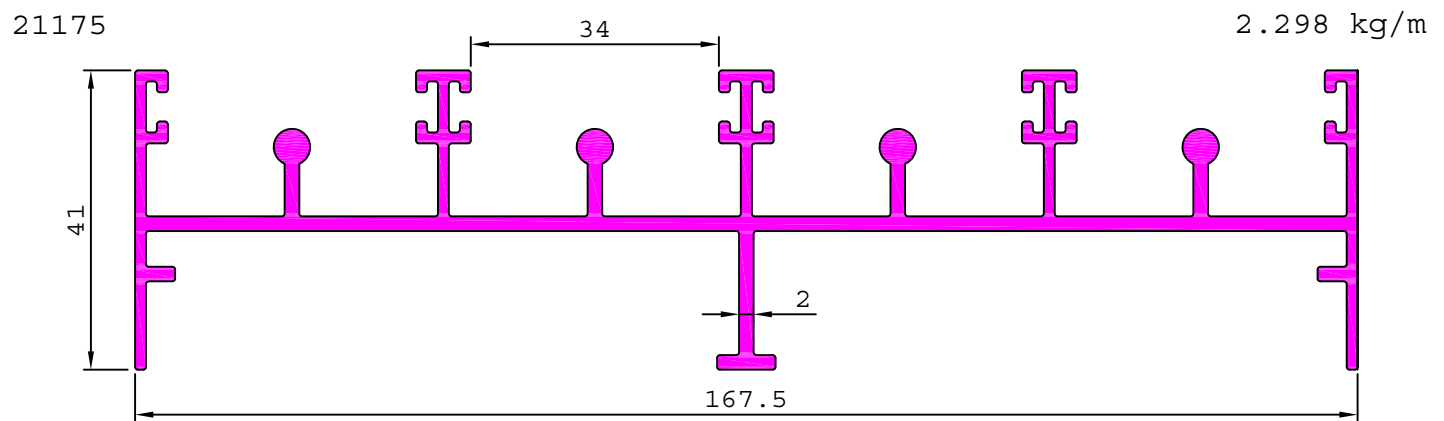
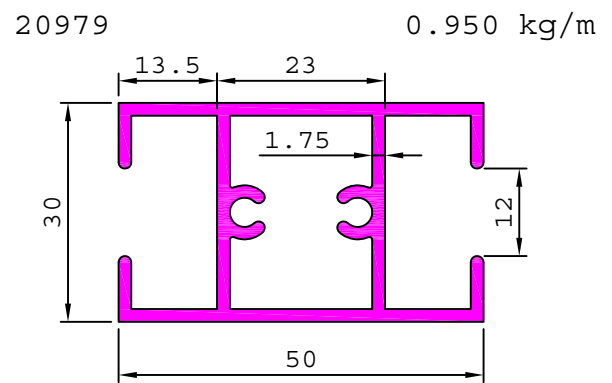
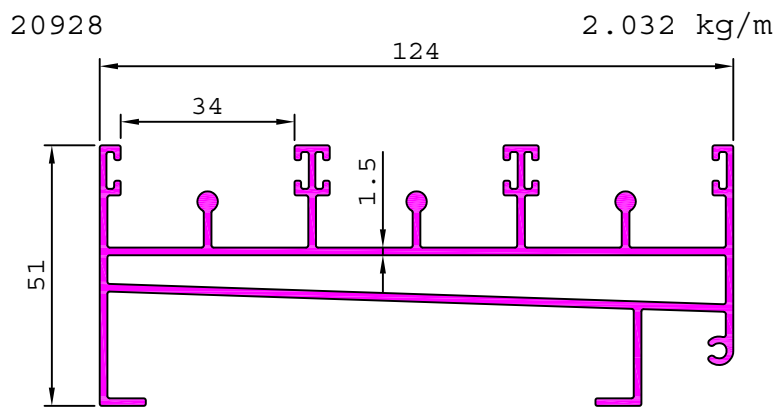
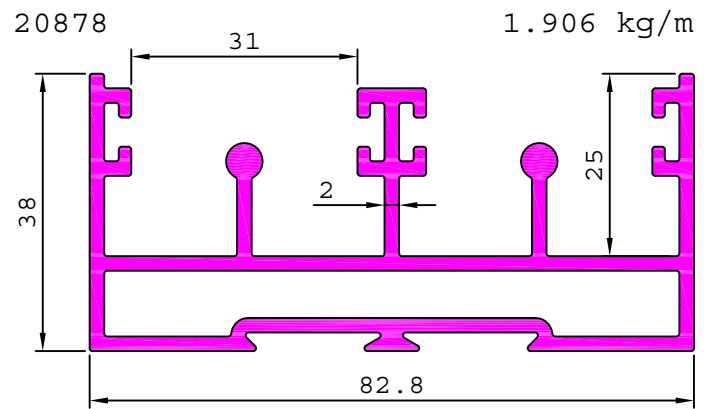
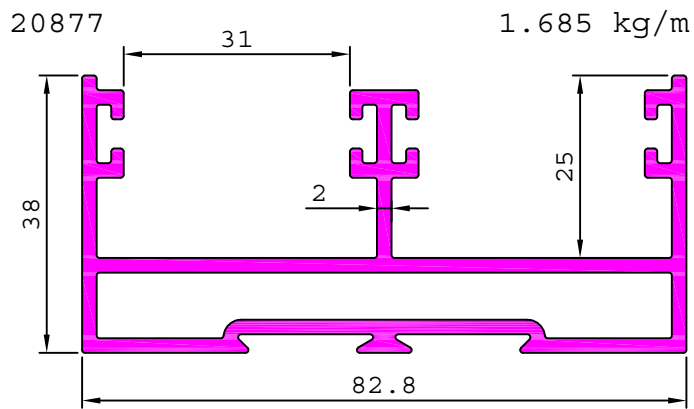



## DETAILS OF SLIDING WINDOW SECTIONS SERIES - E (SHUTTER SECTION - 30 mm.)

21198

3.197 kg/m

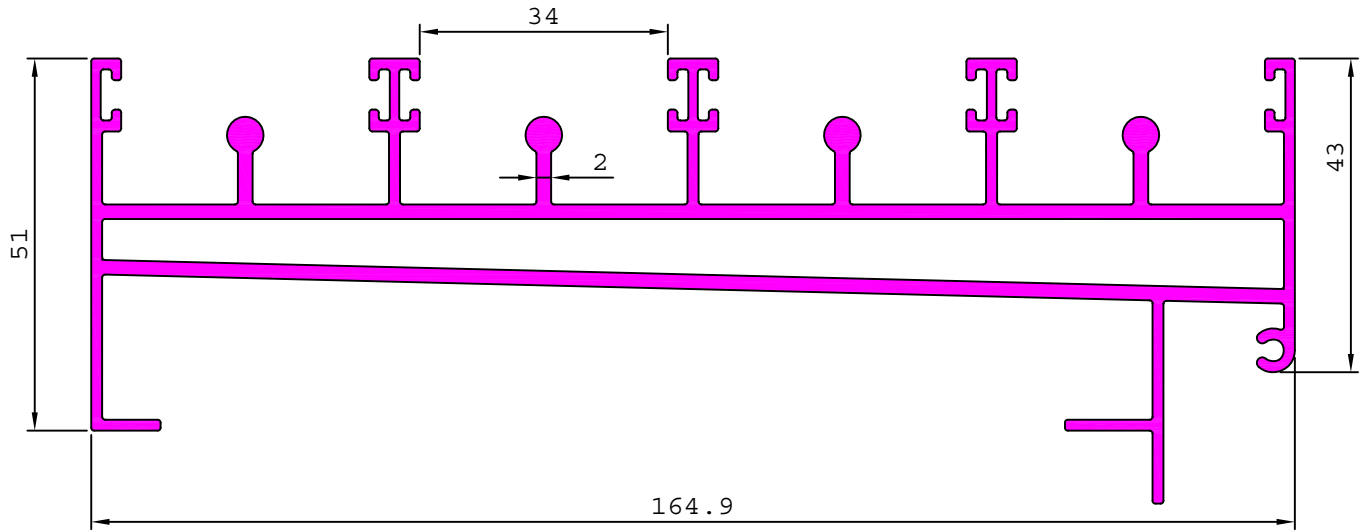

21203

2.073 kg/m

21217

1.502 kg/m

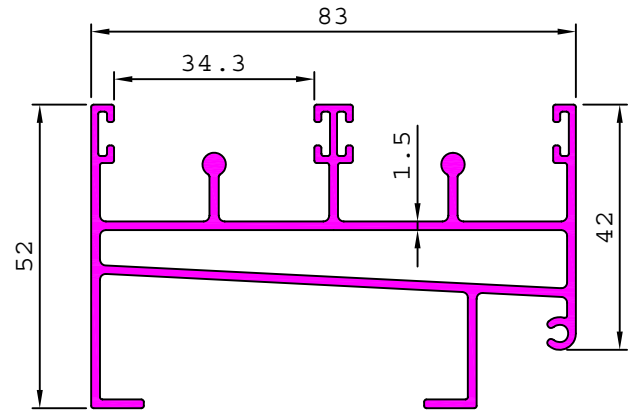
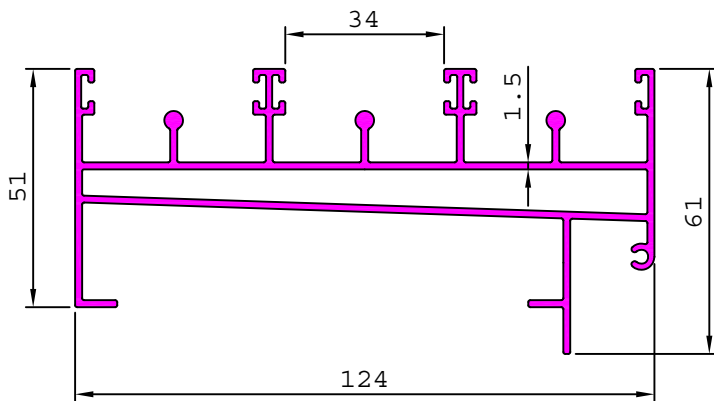

21204

1.694 kg/m

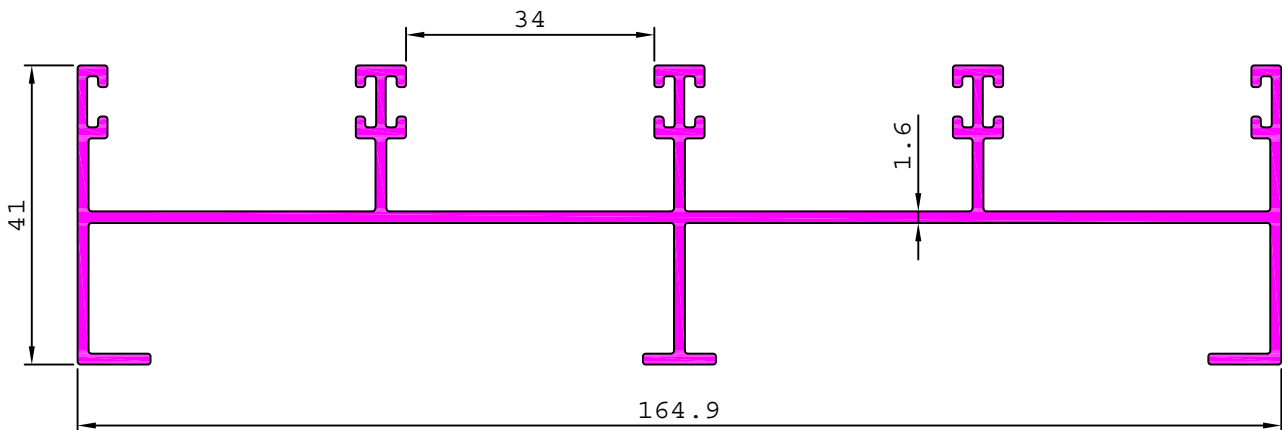

# SUPER PROFILE

## DETAILS OF SLIDING WINDOW SECTIONS SERIES - E (SHUTTER SECTION - 30 mm.)

20631

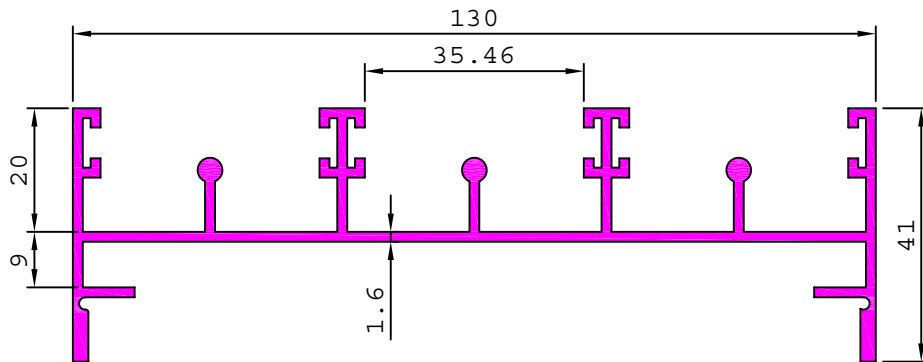

1.613 kg/m

20632

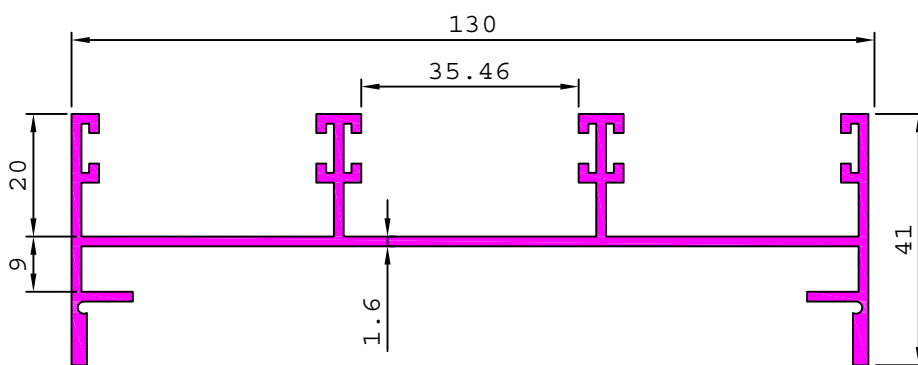

1.408 kg/m

20659

1.278 kg/m

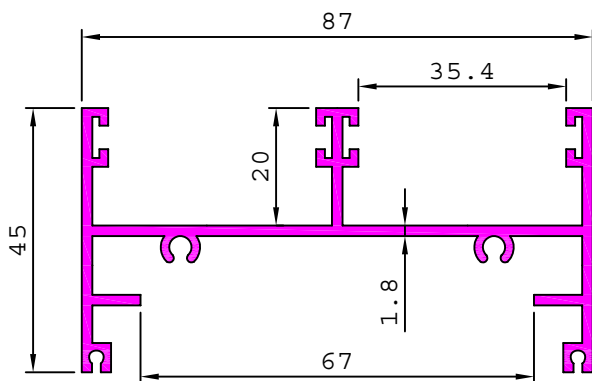

20660

1.709 kg/m

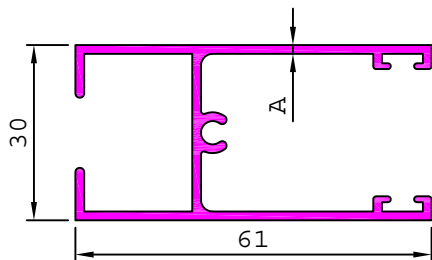
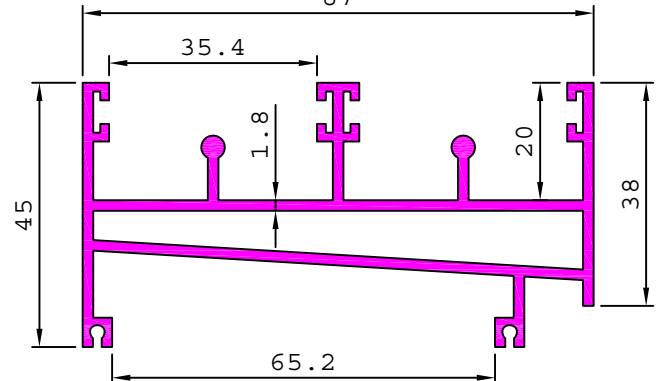

SL. No.	Section No.	A	Weight kg/m
1	20984	1.30	0.668
2	20776	1.50	0.763

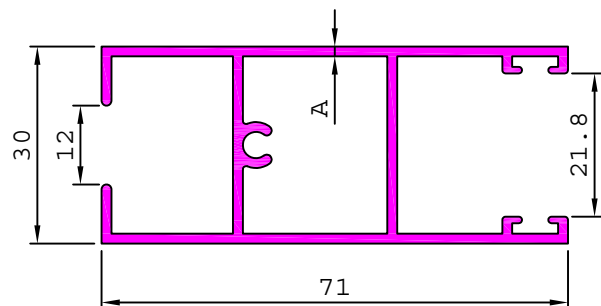

SL. No.	Section No.	A	Weight kg/m
1	20993	1.31	0.839
2	20772	1.50	0.948

# SUPER PROFILE

## DETAILS OF SLIDING WINDOW SECTIONS SERIES - E (SHUTTER SECTION - 30 mm.)

21008 0.762 kg/m

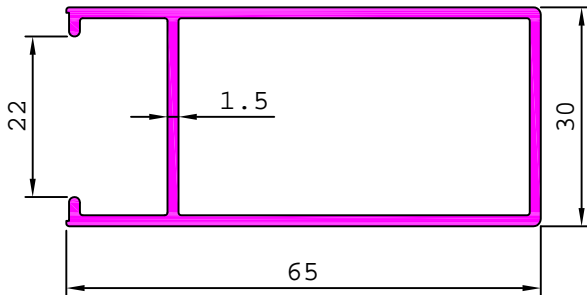

21009 0.964 kg/m

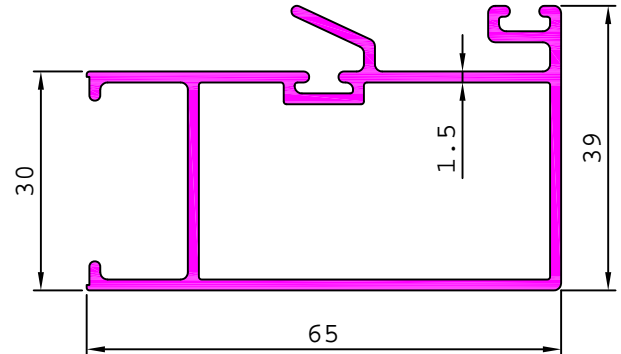

21010 0.995 kg/m

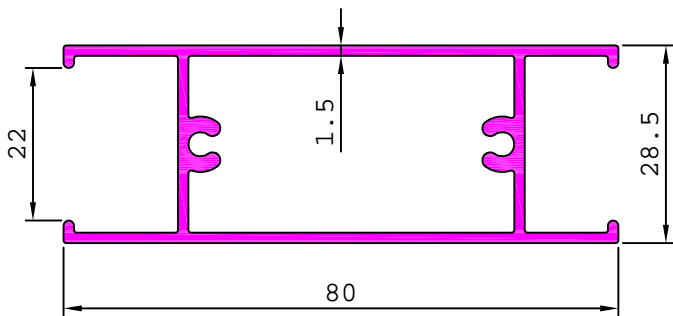

21182 1.208 kg/m

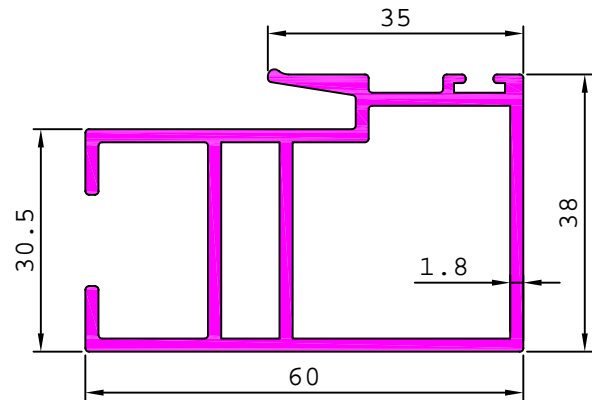

21197 1.071 kg/m

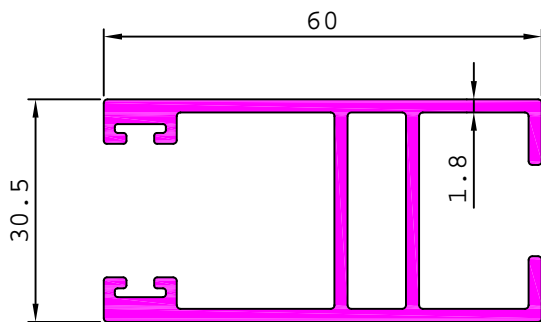

# SUPER PROFILE

## DETAILS OF SLIDING WINDOW SECTIONS SERIES - E (SHUTTER SECTION - 30 mm.)

21205

0.846 kg/m

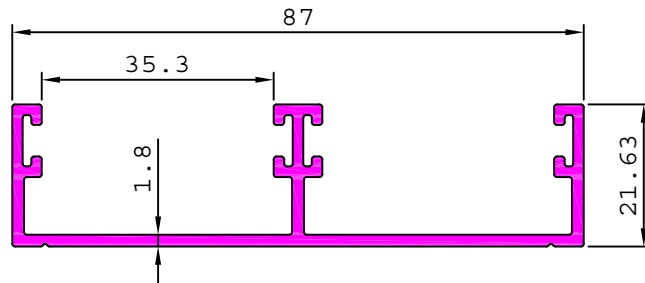

21206

1.223 kg/m

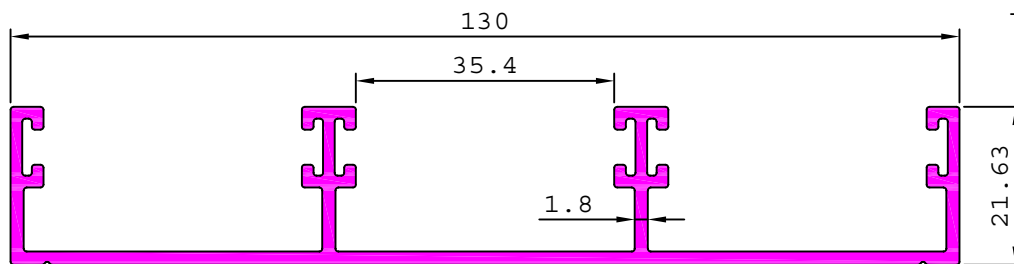

21243

2.586 kg/m

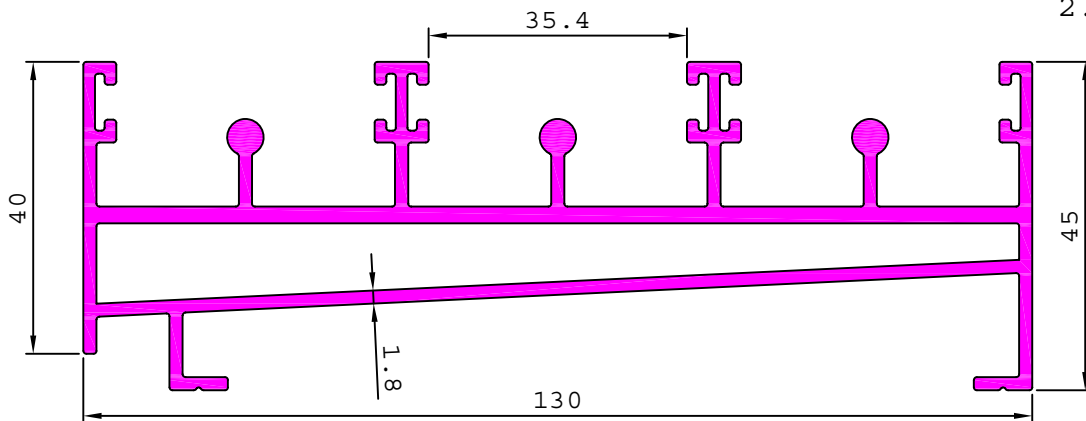

21244

3.415 kg/m

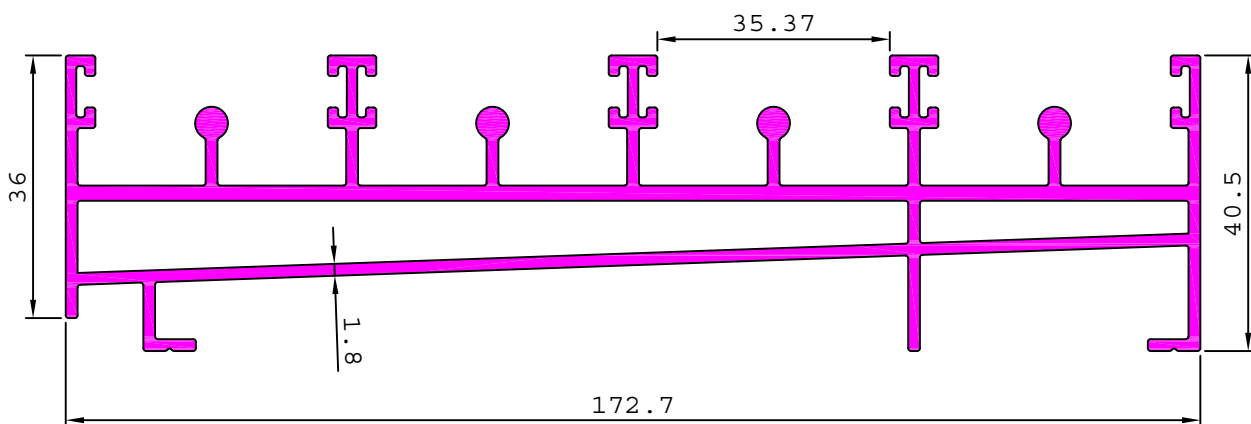

# SUPER PROFILE

## DETAILS OF SLIDING WINDOW SECTIONS SERIES - E (SHUTTER SECTION - 30 mm.)

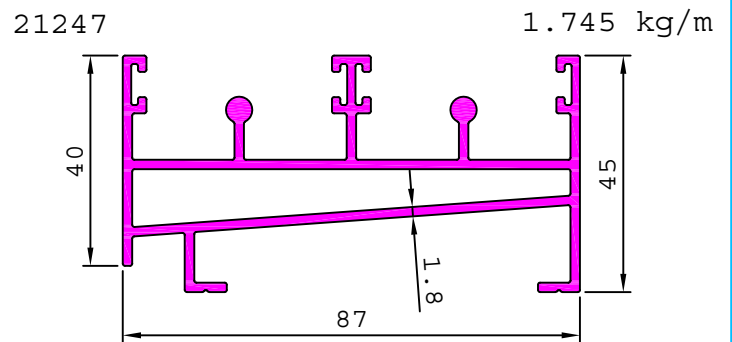
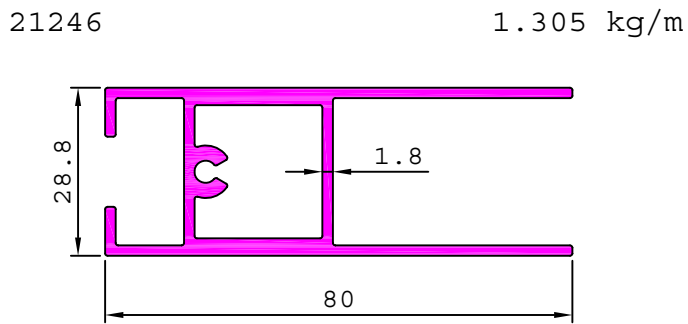
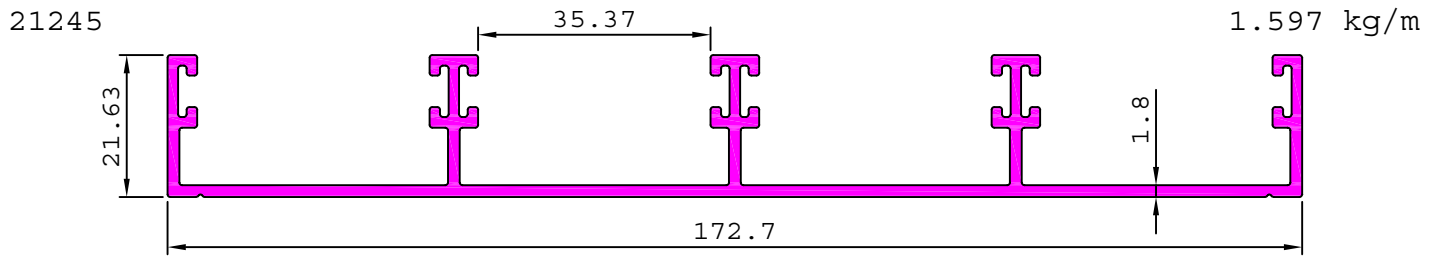

# SUPER PROFILE

## DETAILS OF SLIDING WINDOW SECTIONS SERIES - F (SHUTTER SECTION - 40 mm.)

21248

3.950 kg/m

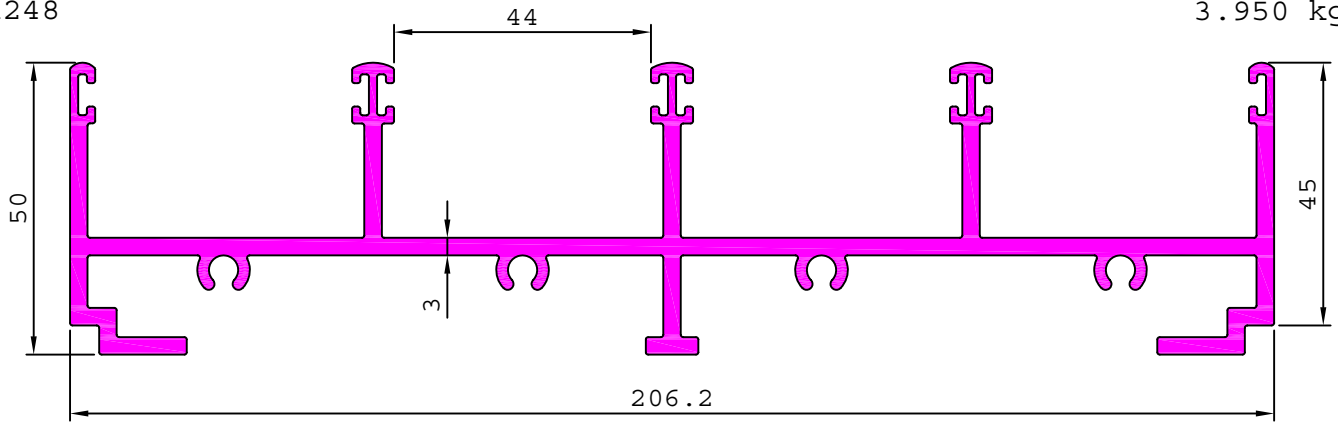

21249

6.961 kg/m

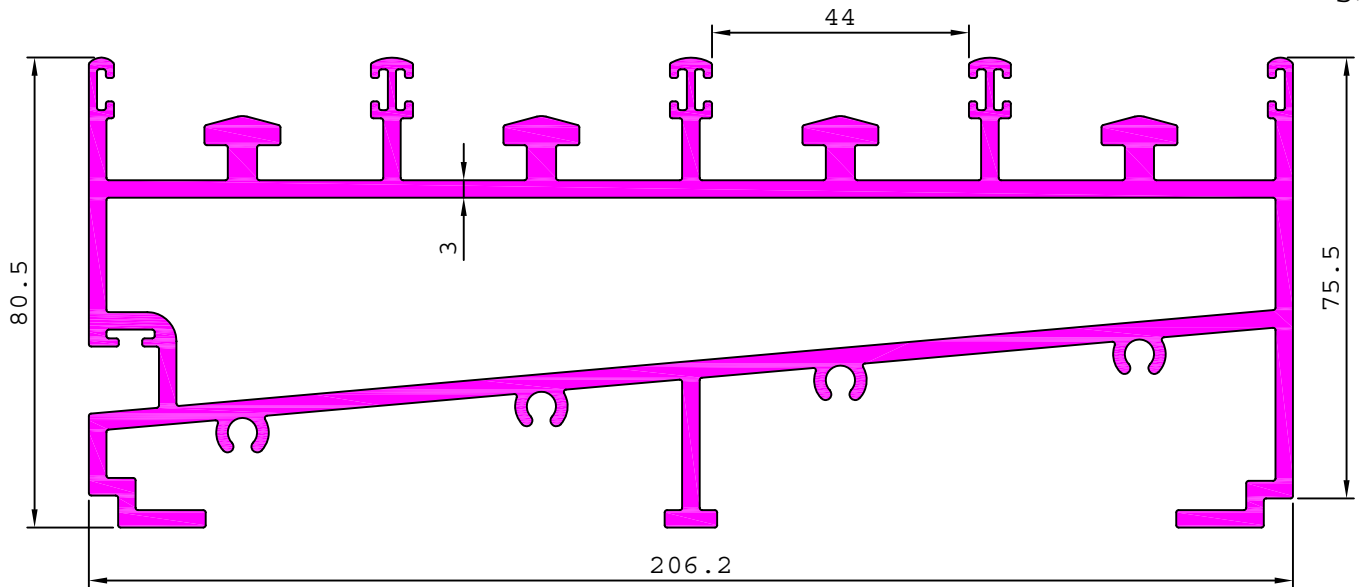

## SERIES - G (SHUTTER SECTION - 45 mm.)

21224

2.395 kg/m

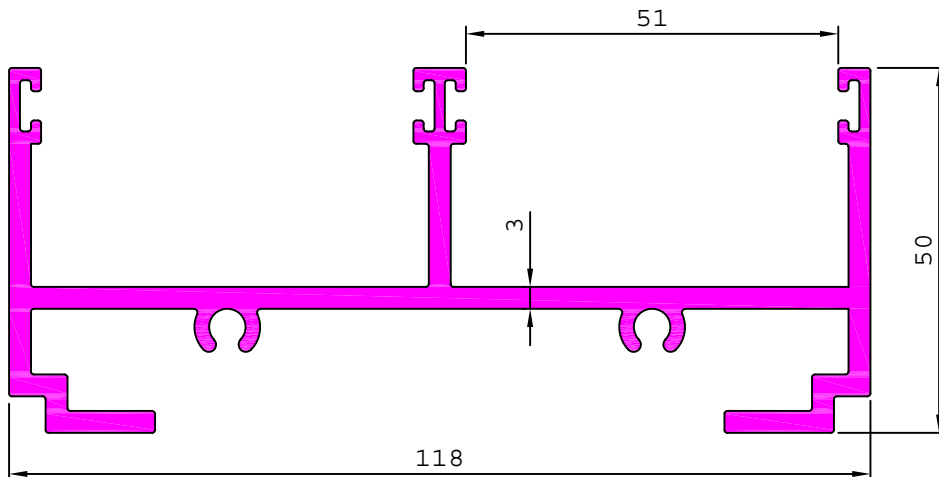

# SUPER PROFILE

## DETAILS OF SLIDING WINDOW SECTIONS SERIES - G (SHUTTER SECTION - 45 mm.)

21218 4.744 kg/m

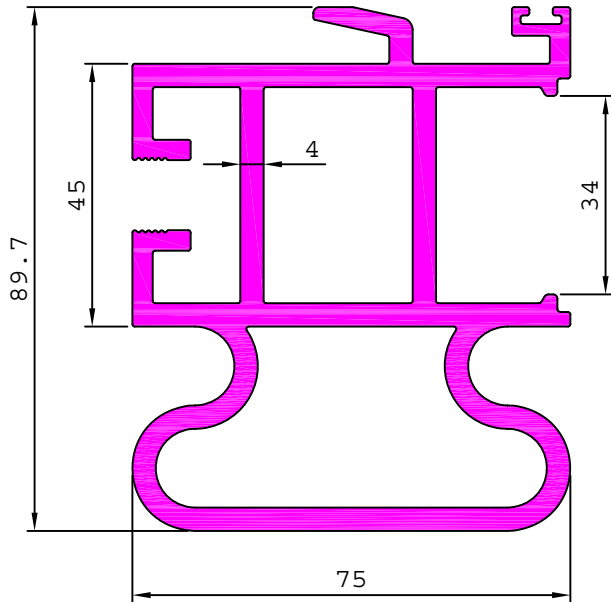

21219 3.988 kg/m

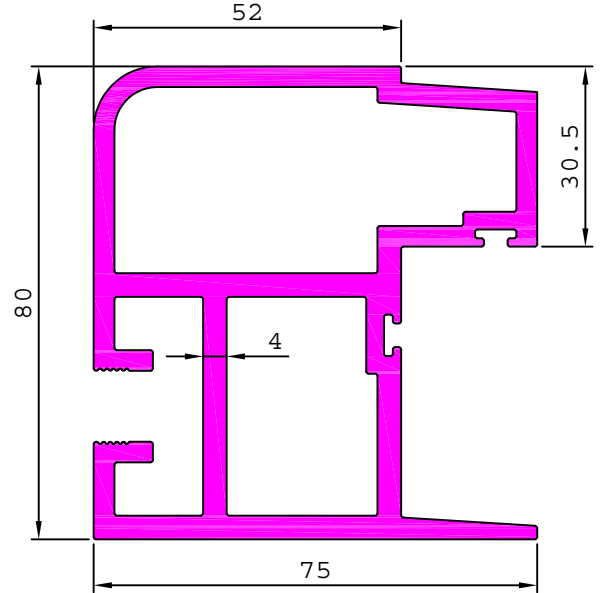

21220 3.992 kg/m

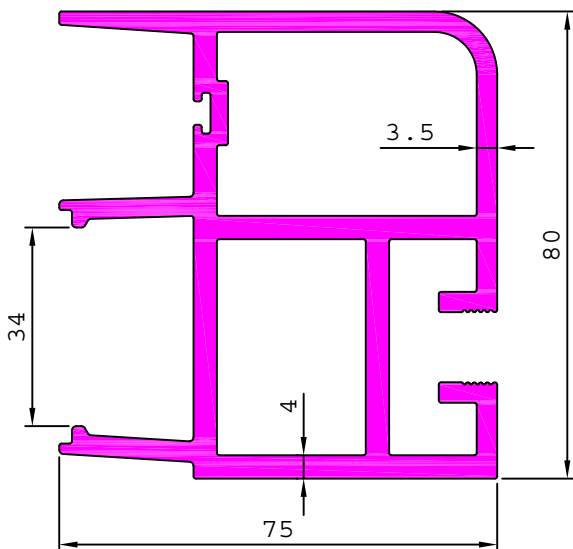

21221 4.439 kg/m

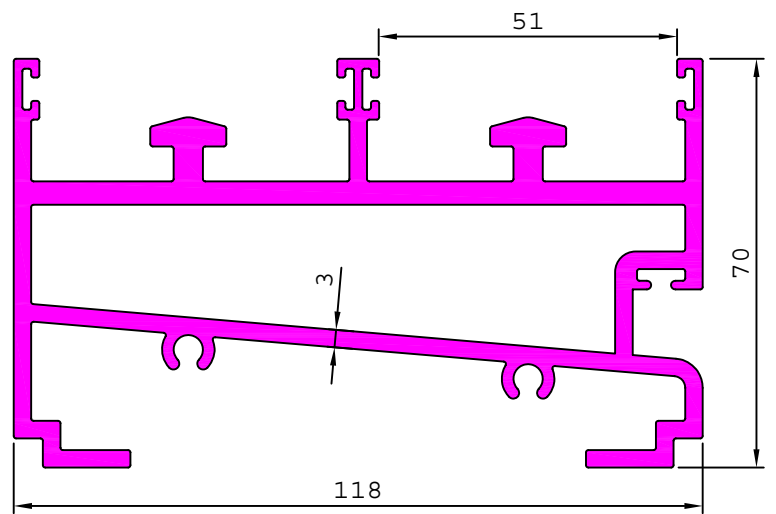

21222 2.774 kg/m

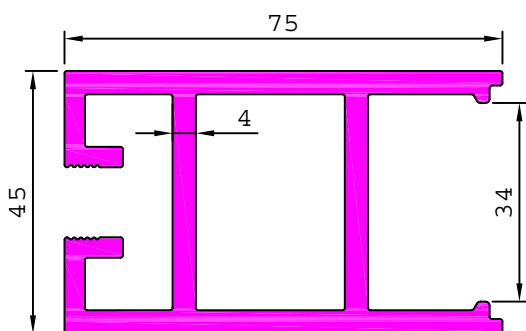

21223 3.405 kg/m

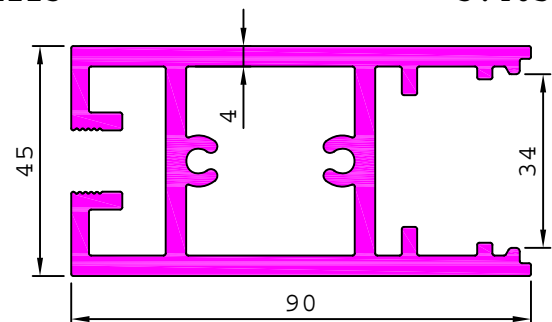

## DETAILS OF SLIDING WINDOW SECTIONS SERIES - H (SHUTTER SECTION - 55 mm.)

21124

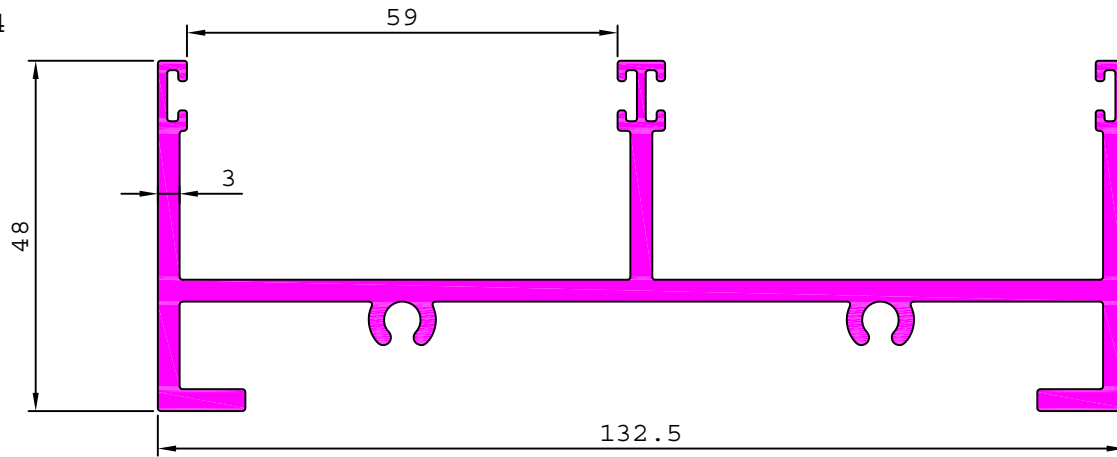

2.314 kg/m

21125

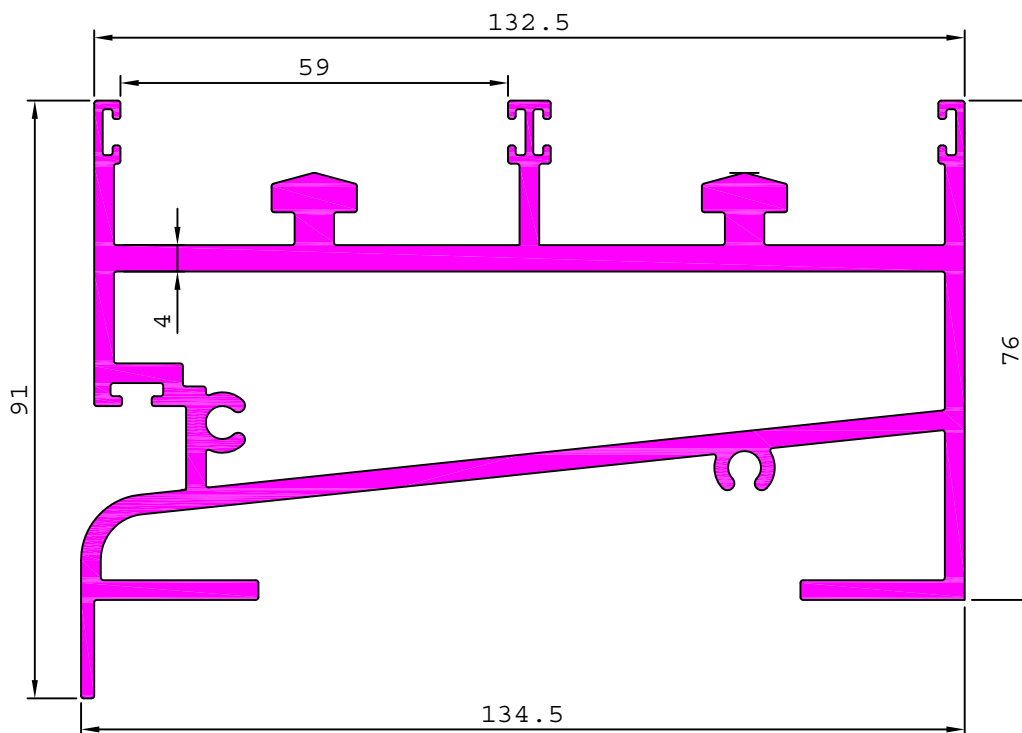

5.038 kg/m

21126

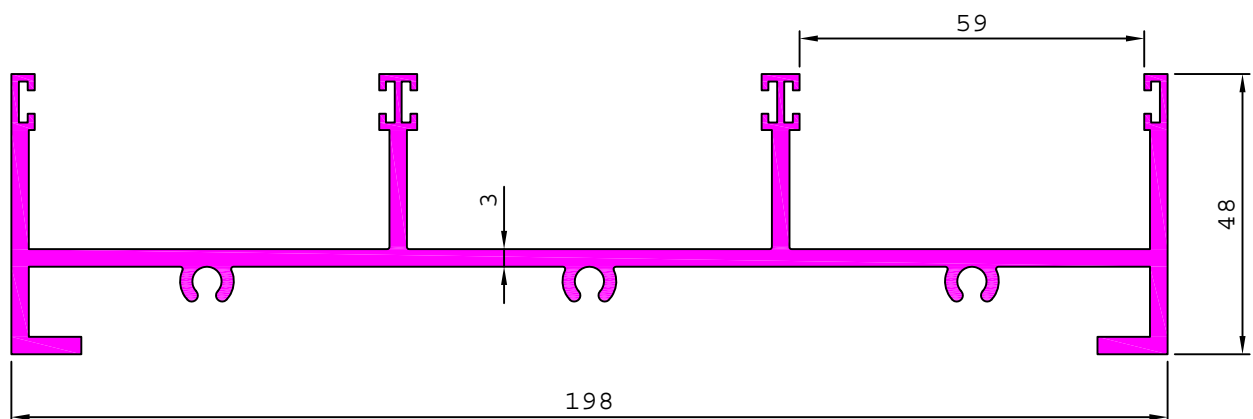

3.170 kg/m



# SUPER PROFILE

## DETAILS OF SLIDING WINDOW SECTIONS SERIES - H (SHUTTER SECTION - 55 mm.)

21127

6.800 kg/m

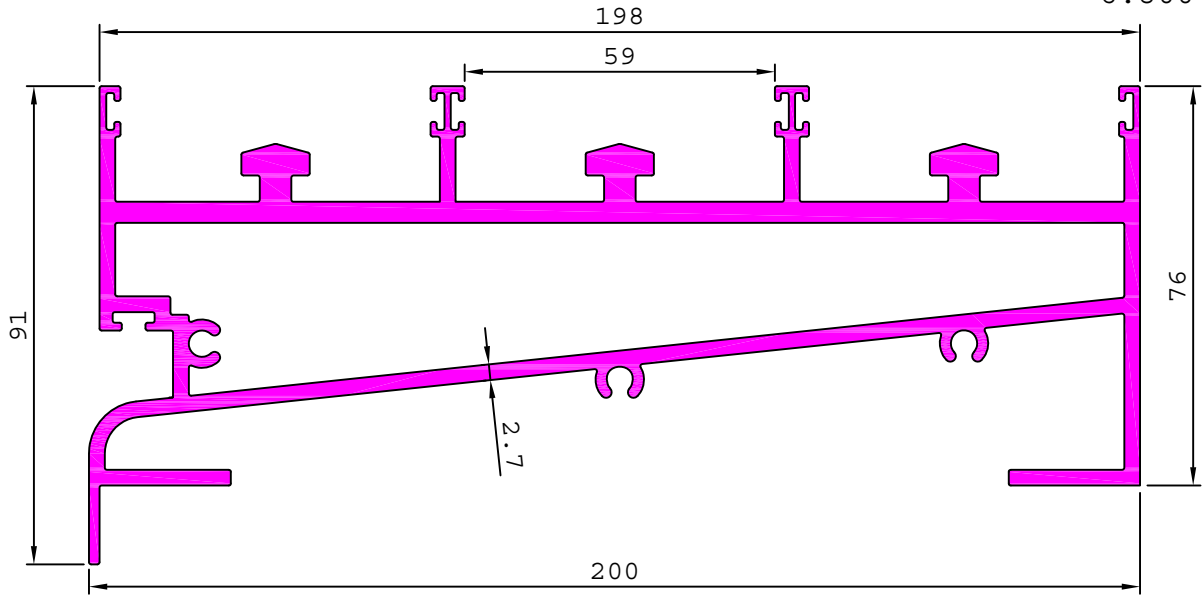

21128

3.402 kg/m

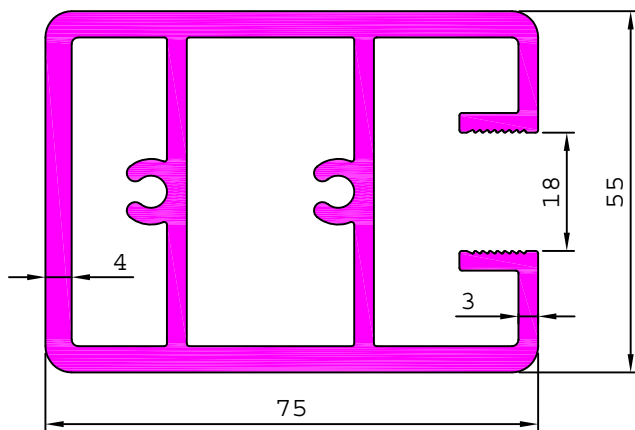

21129

3.141 kg/m

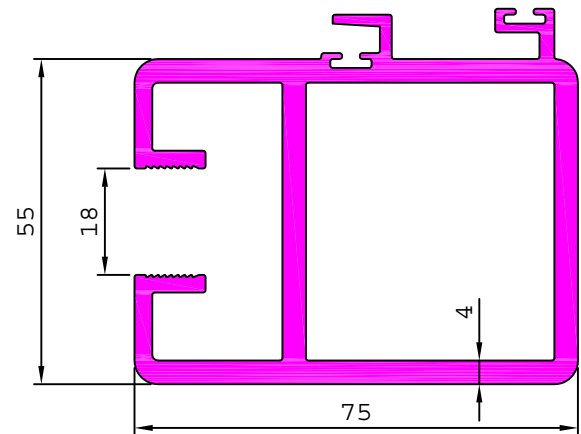

21130

3.458 kg/m

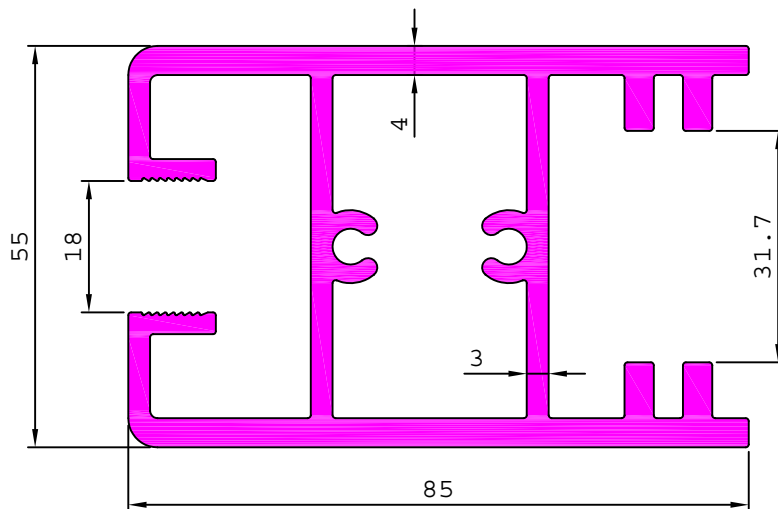

## DETAILS OF SLIDING WINDOW SECTIONS SERIES - H (SHUTTER SECTION - 55 mm.)

211131 70 3.767 kg/m

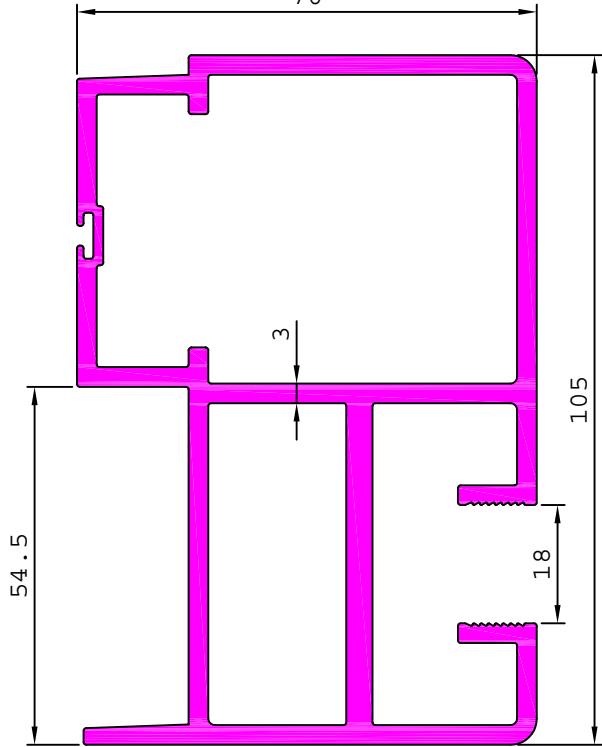

211132 69 3.761 kg/m

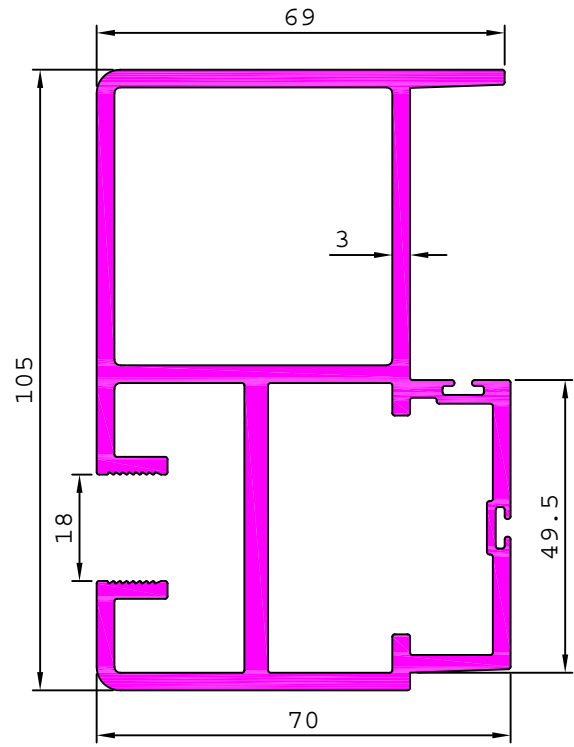

211133 50 4.640 kg/m

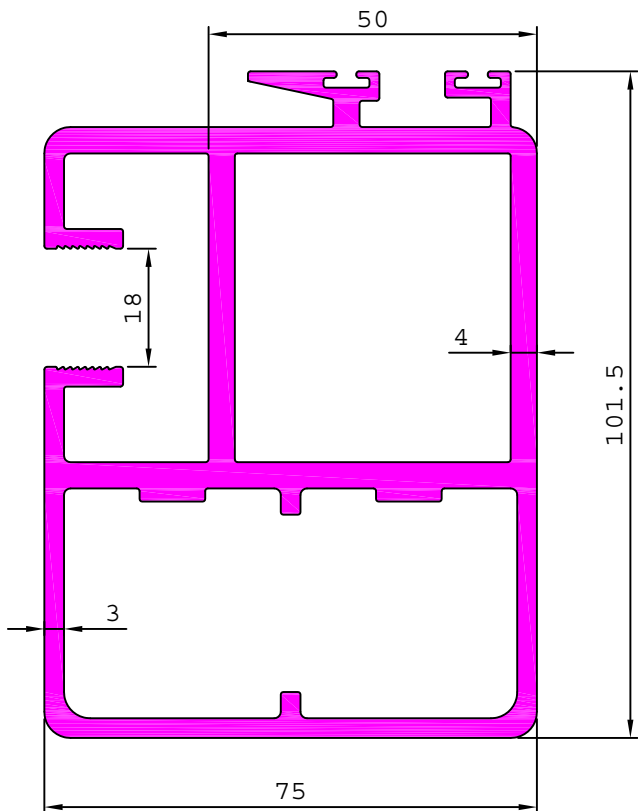

211134 75 5.002 kg/m

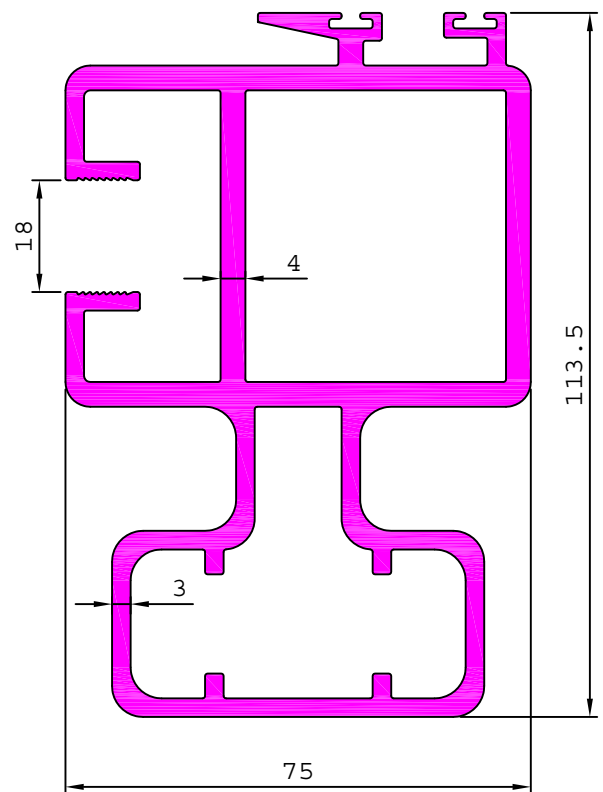

## DETAILS OF SLIDING WINDOW SECTIONS SERIES - I (SHUTTER SECTION - 60 mm.)

21258

3.185 kg/m

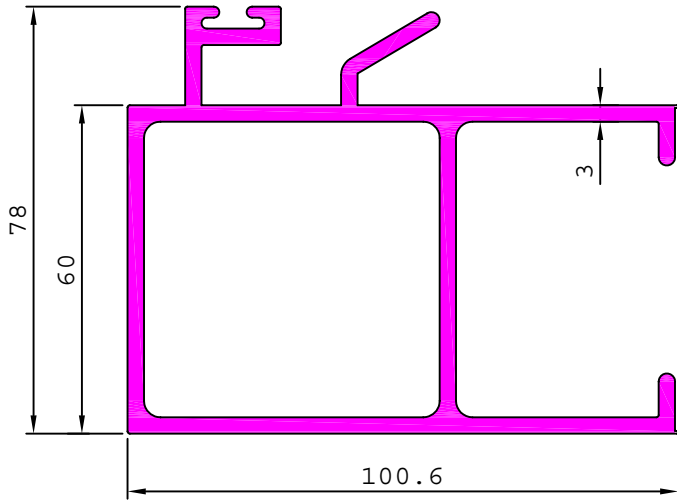

21261

2.814 kg/m

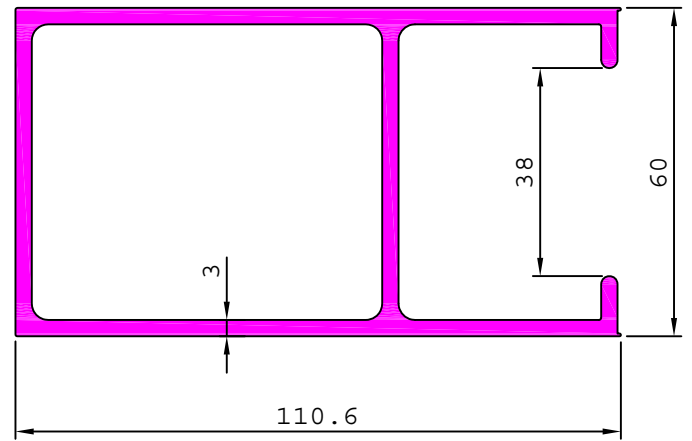

21259

4.031 kg/m

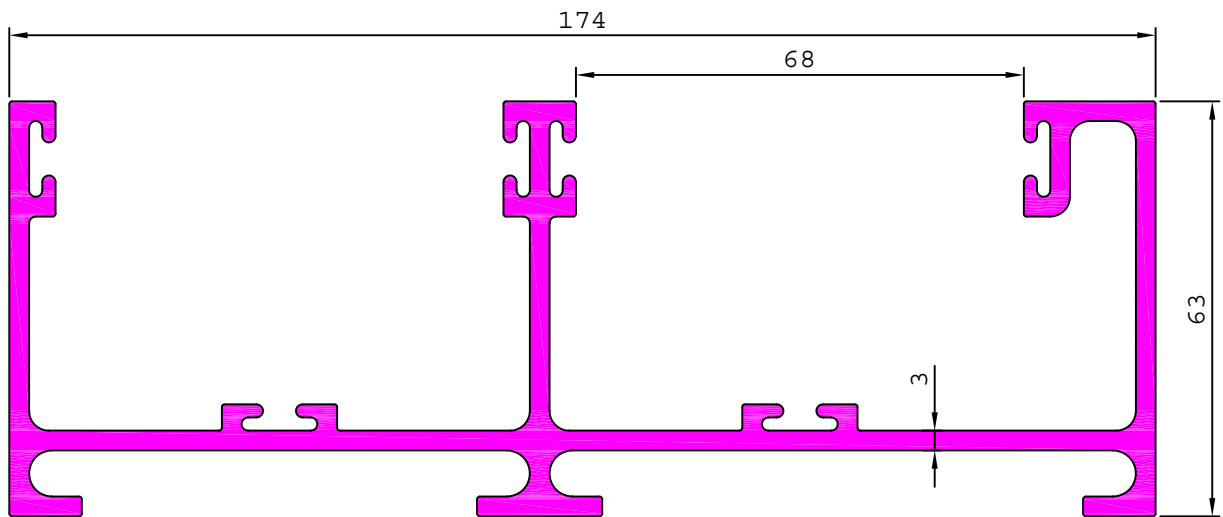

21260

3.733 kg/m

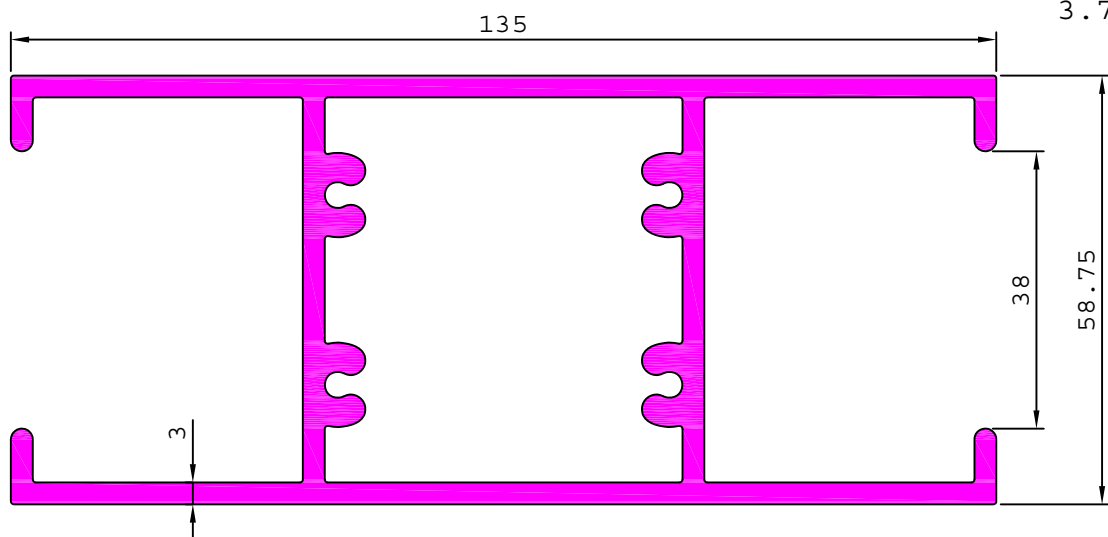

# SUPER PROFILE

## DETAILS OF SLIDING WINDOW SECTIONS SERIES - I (SHUTTER SECTION - 60 mm.)

21262

1.780 kg/m

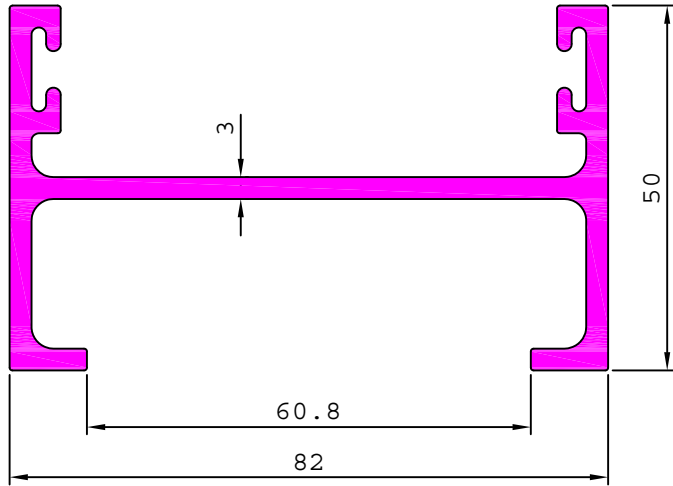

21264

3.275 kg/m

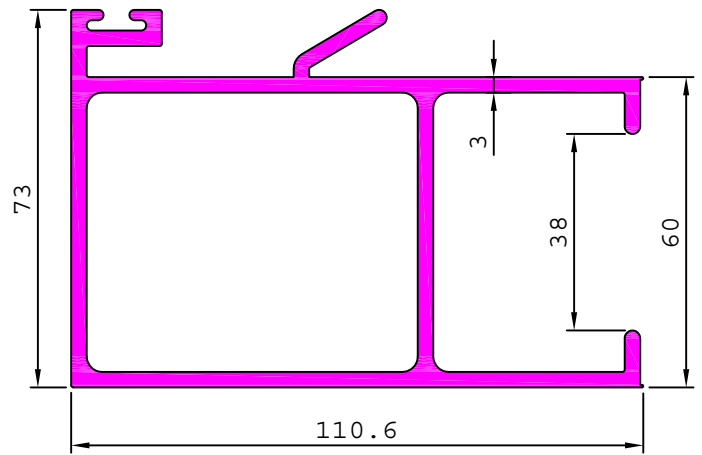

21263

7.198 kg/m

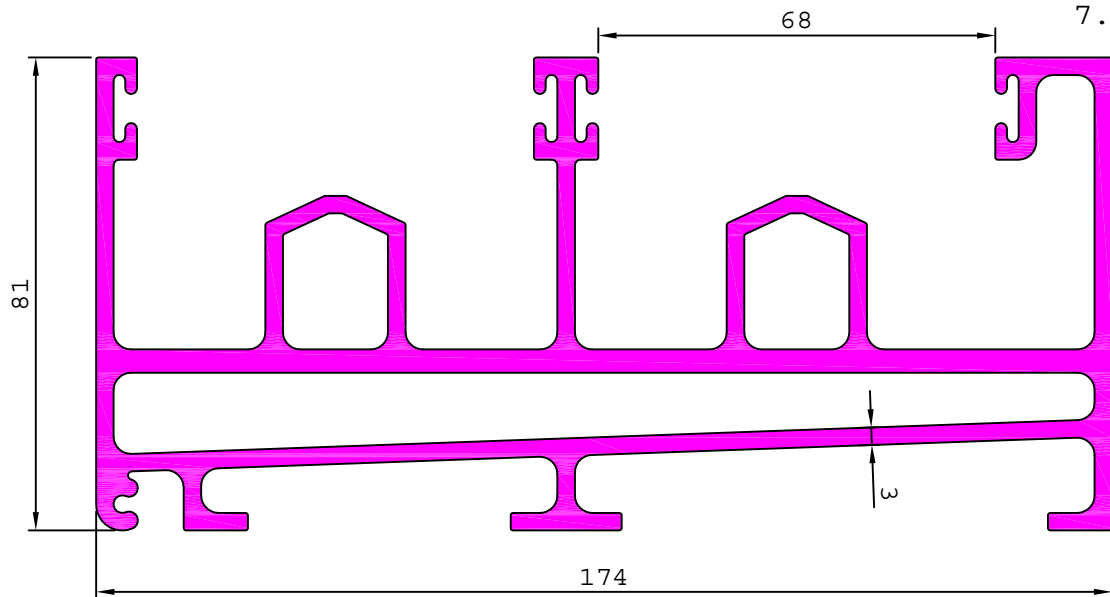

21266

3.652 kg/m

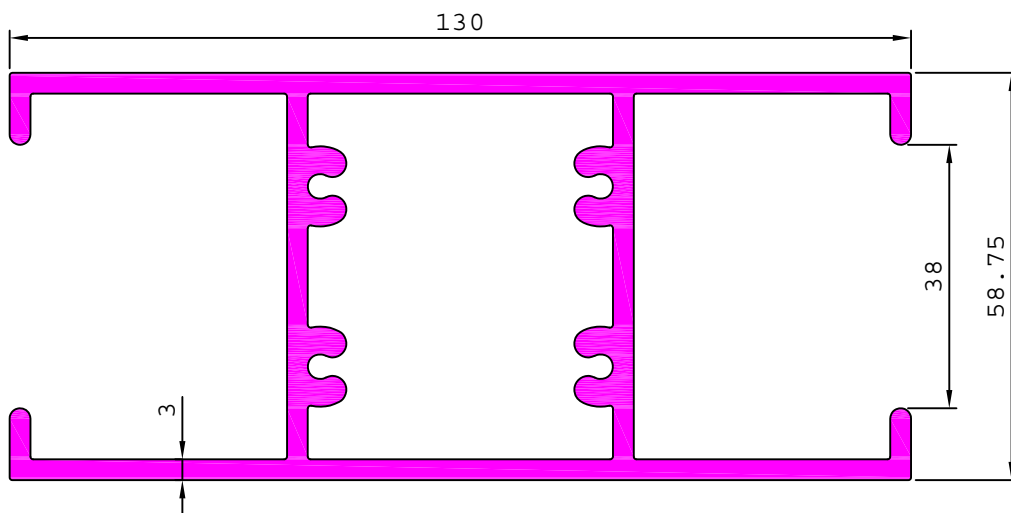

## DETAILS OF SLIDING WINDOW SECTIONS SERIES - I (SHUTTER SECTION - 60 mm.)

21265

2.815 kg/m

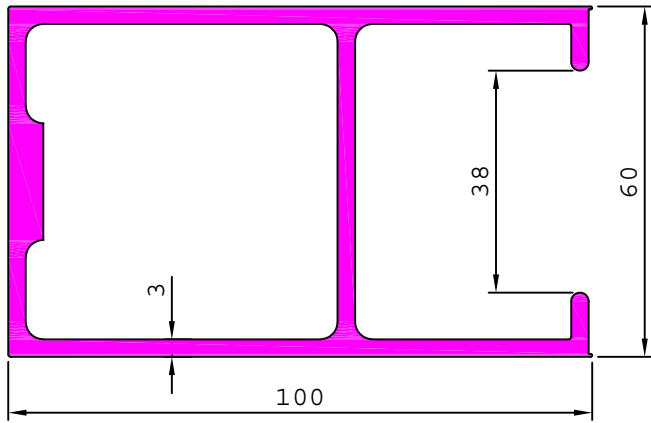

21269

2.042 kg/m

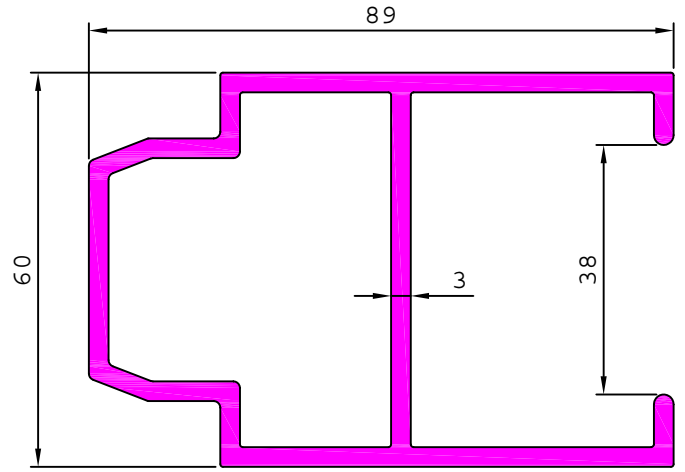

21267

3.642 kg/m

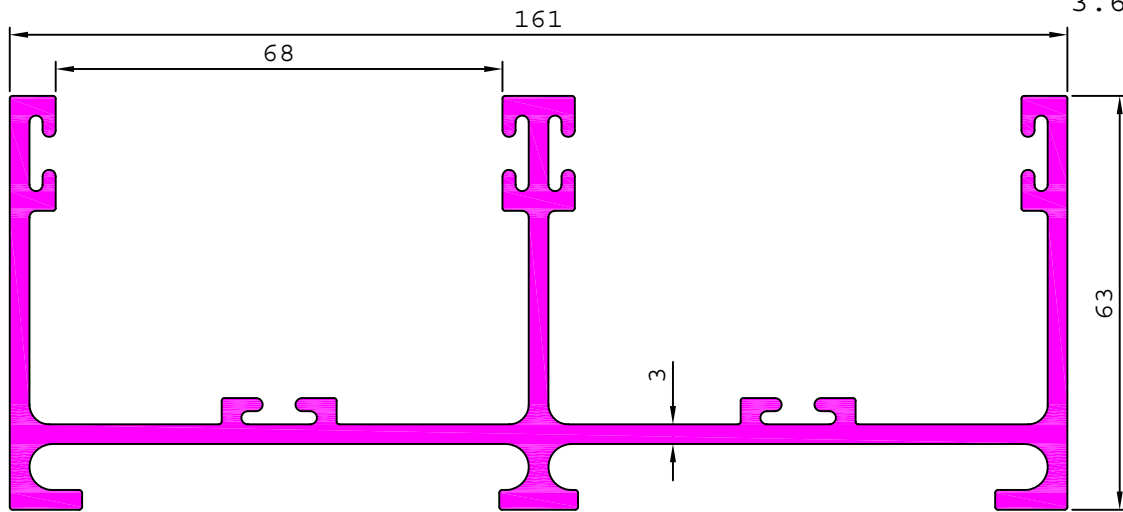

21268

6.662 kg/m

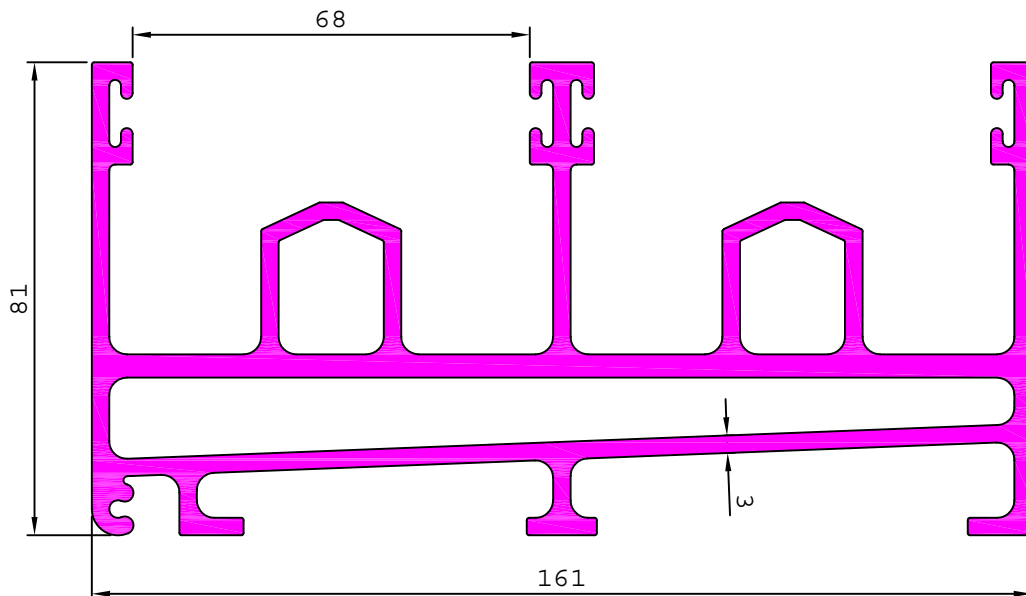

# SUPER PROFILE

## DETAILS OF SLIDING WINDOW SECTIONS SERIES - I (SHUTTER SECTION - 60 mm.)

21270

2.068 kg/m

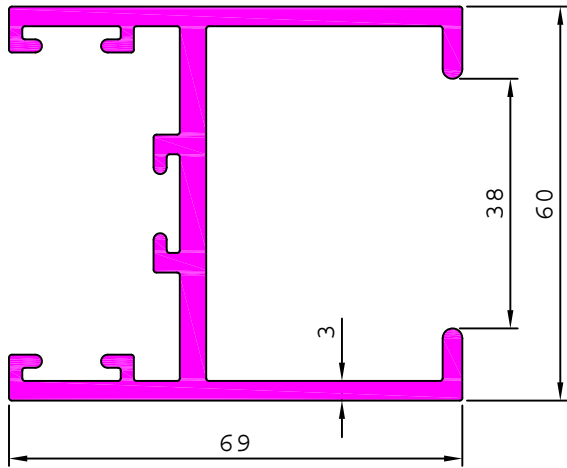

21299

2.103 kg/m

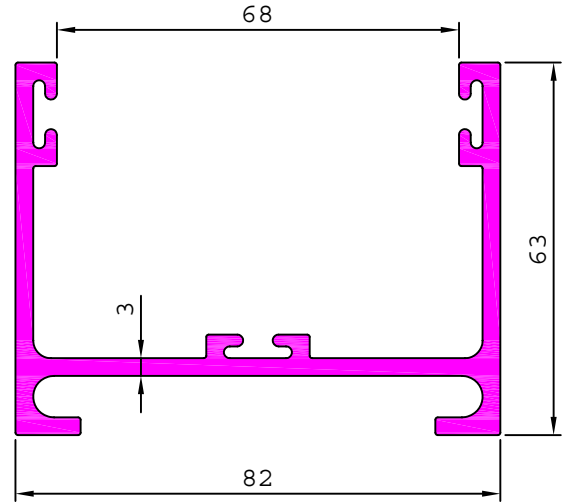

21271

9.521 kg/m

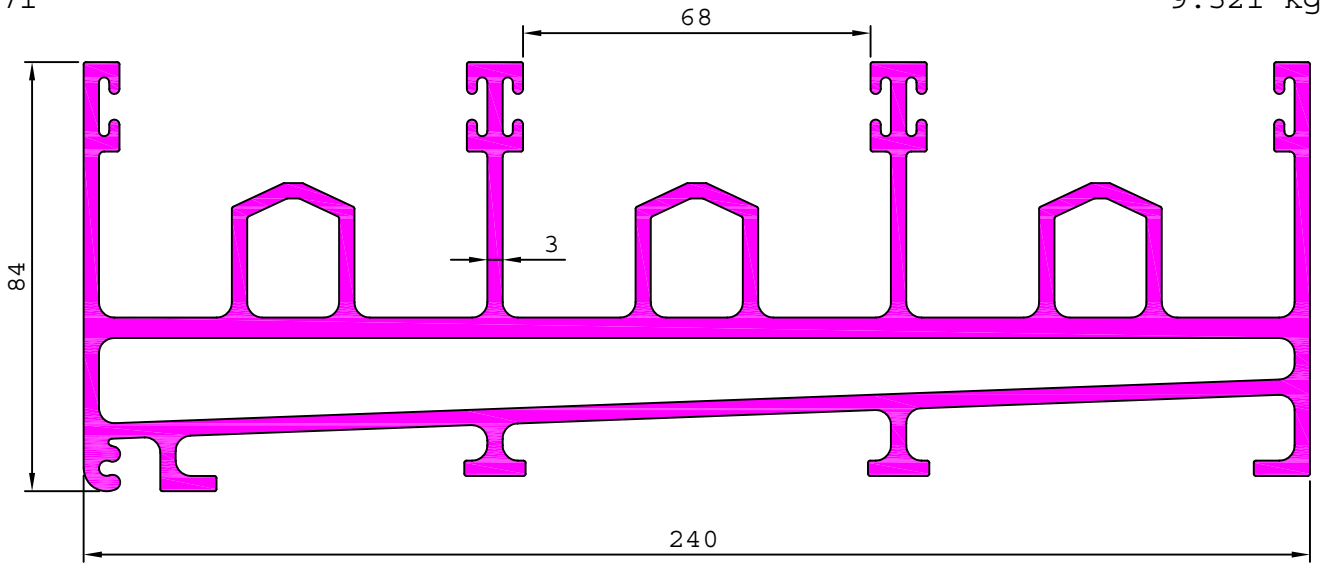

21272

4.998 kg/m

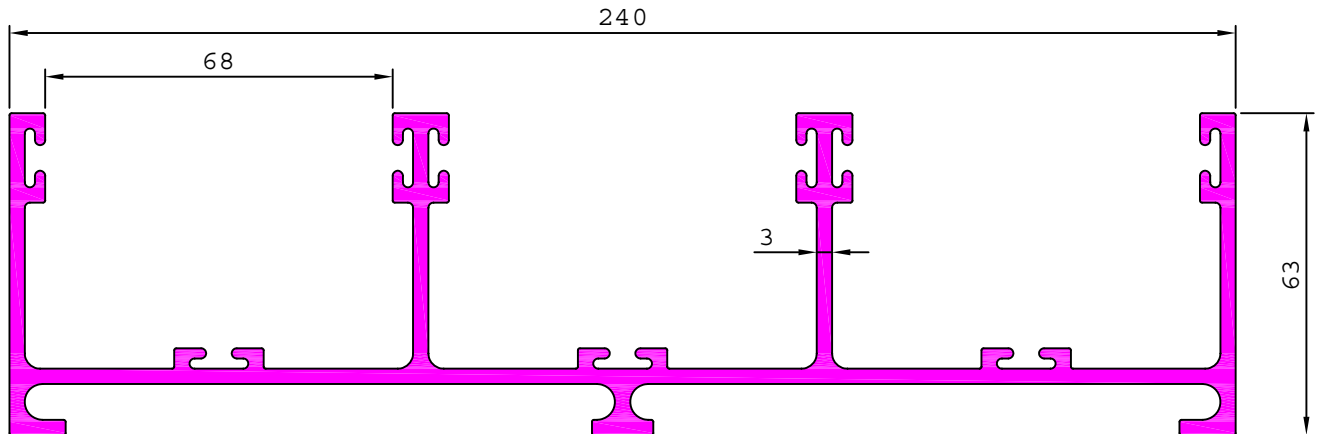

# SUPER PROFILE

## DETAILS OF SLIDING WINDOW SECTIONS SERIES - I (SHUTTER SECTION - 60 mm.)

21300 3.876 kg/m

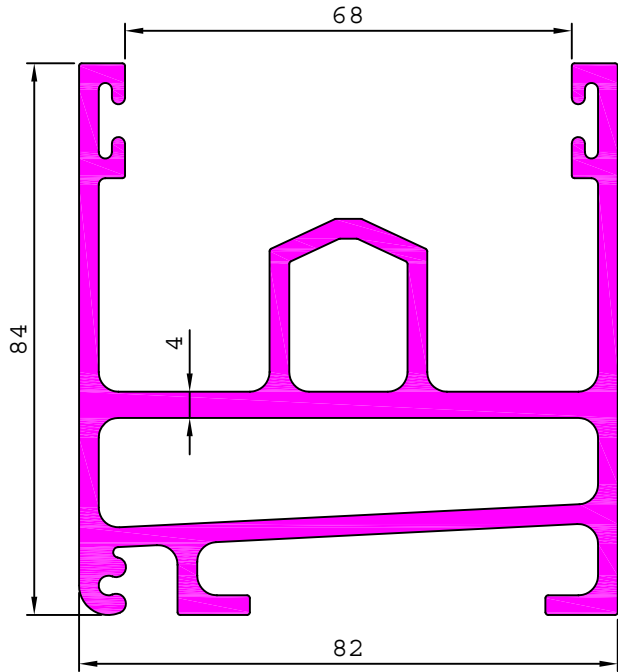

21301 3.136 kg/m

