

CASEMENT WINDOW

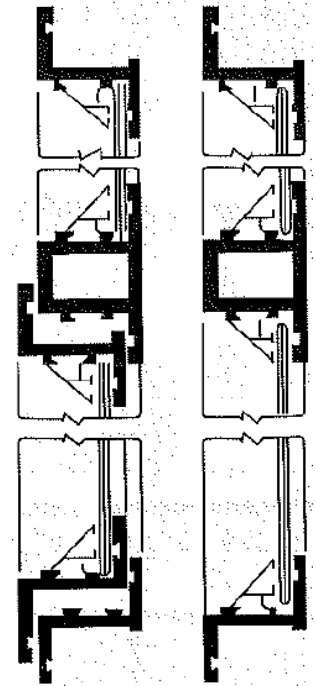

Detail at - as Detail at - ih

casement windows (Hinged Type) are simple in design. They are mostly used in residential applications. the windows gave hinged panels which open either on the inside or outside. Some windows have additional panes for fixing mosquito mesh, grills etc. These windows can also be made out of hollow shapes which have grooves for weather strips. Extruded glazing clips are used for fixing glass. This will eliminate display of screws.

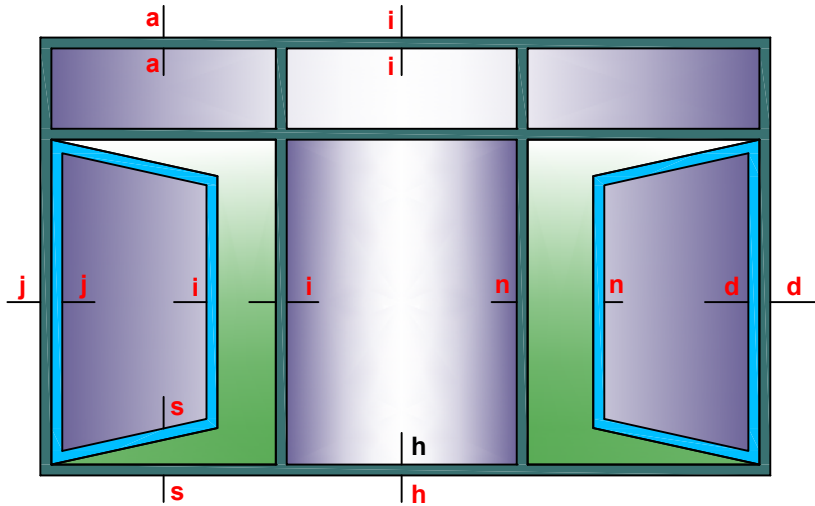

Detail at - jj

Detail at - ii

Detail at - nn

Detail at - dd

JINDAL SECTION NUMBERS FOR CASEMENT WINDOW

SECTION DESCRIPTION	SOLID SECTIONS			HOLLOW SECTIONS		
	SINGLE SHUTTER		DOUBLE SHUTTER	SERIES - A	SERIES - B	SERIES - C
	SERIES - A	SERIES - B				
FRAME	20653 20654	20509, 20585, 20627, 20940, 20948, 20949,	20513 21034	20533	20535	-----
MULLION	20658	20510, 20941,	20510, 20941,	20534	20536	20658
SHUTTER WITH GLASS	20653 20654	20509 20940	20509 20654 20940	20533	20535	-----
GLAZING CLIP	19352, 19360, 19361, 19366, 19370, 19377, 19382,	19352, 19360, 19361, 19366, 19370, 19377, 19382,	19352, 19360, 19361, 19366, 19370, 19377, 19382,	19389	19390	19352, 19360, 19361, 19366, 19370, 19377, 19382,
SHUTTER WITH MESH	-----	-----	20511 20512	-----	-----	-----

SUPER PROFILE

DETAILS OF CASEMENT WINDOW SECTIONS

20511 0.155 kg/m

SL. No.	Section No.	A	B	Weight kg/m
1	20941	14.80	2.10	0.851
2	20510	14.82	2.50	1.123

20512 0.914 kg/m

SL. No.	Section No.	A	Weight kg/m
1	21034	2.64	1.555
2	20513	3.00	1.705

SL. No.	Section No.	A	B	Weight kg/m
1	20940	14.80	1.95	0.408
2	20509	14.82	3.00	0.663

SL. No.	Section No.	A	Weight kg/m
1	21033	2.64	0.945
2	20515	3.00	1.056

20533 0.549 kg/m

20534 0.502 kg/m

20535 1.065 kg/m

SUPER PROFILE

DETAILS OF CASEMENT WINDOW SECTIONS

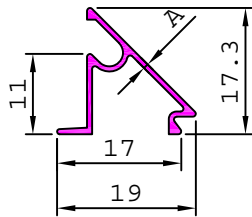

SL. No.	Section No.	A	Weight kg/m
1	19352	0.70	0.097
2	19370	0.80	0.109
3	19360	0.90	0.124

19389

0.157 kg/m

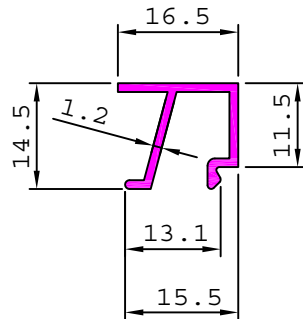

19390

0.266 kg/m

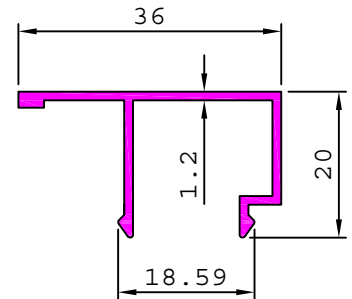

20536

1.065 kg/m

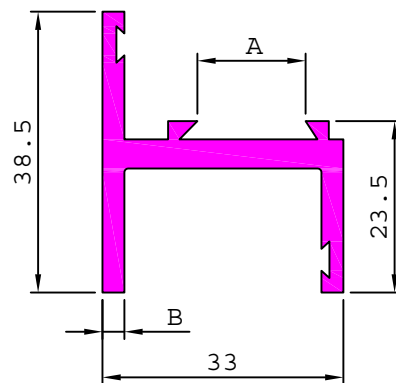
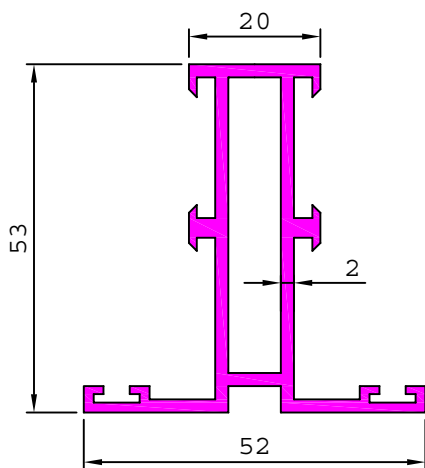

SL. No.	Section No.	A	B	Weight kg/m
1	20949	14.80	2.03	0.497
2	20948	14.80	2.56	0.606
3	20585	14.82	3.00	0.775

20640

0.590 kg/m

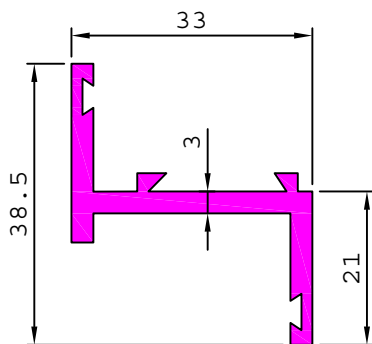

20653

0.354 kg/m

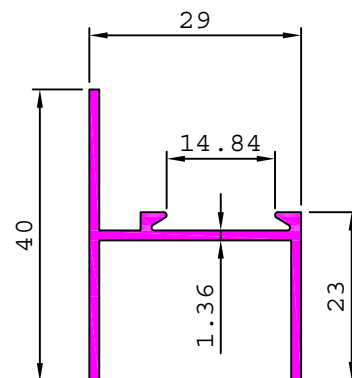

DETAILS OF CASEMENT WINDOW SECTIONS

20654

0.364 kg/m

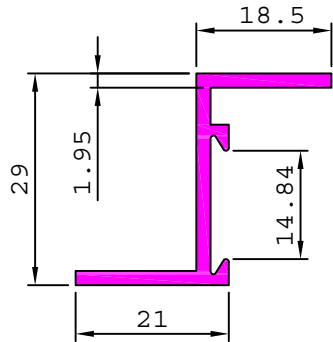

20658

0.367 kg/m

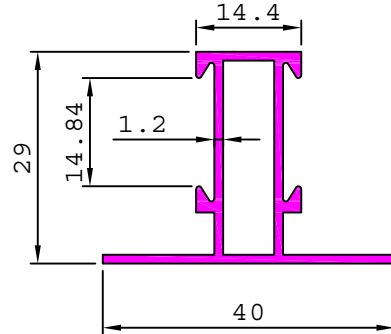

20759

0.483 kg/m

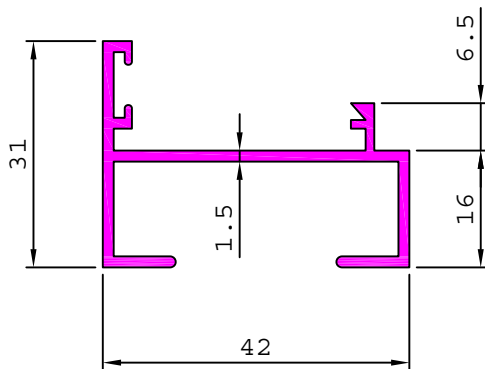

20760

0.610 kg/m

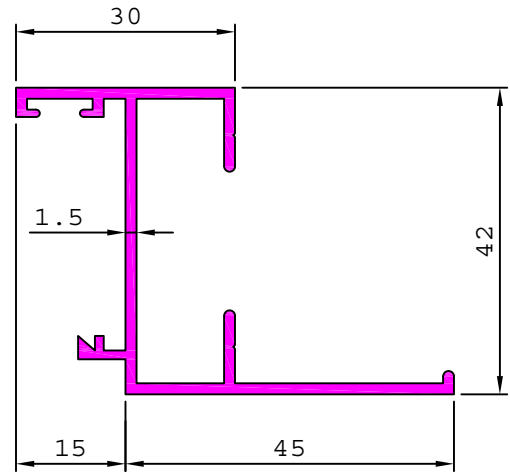

20761

0.591 kg/m

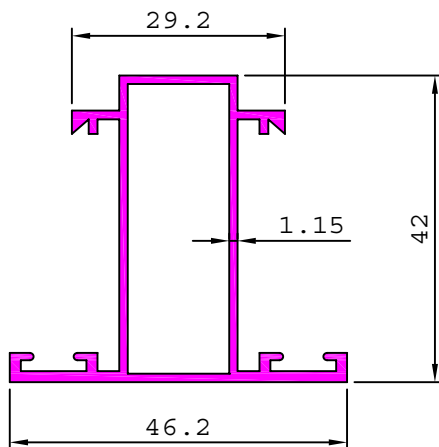

20762

0.848 kg/m

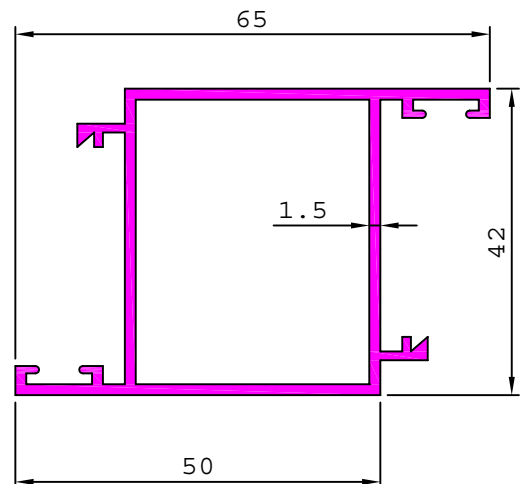

DETAILS OF CASEMENT WINDOW SECTIONS

20763

0.591 kg/m

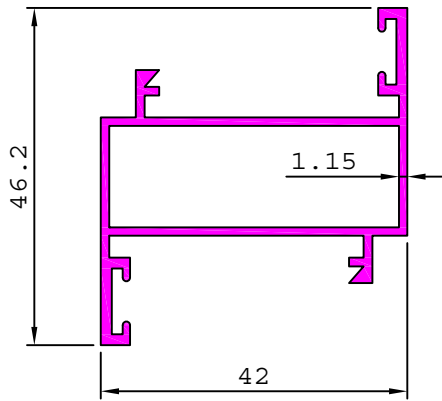

20764

0.805 kg/m

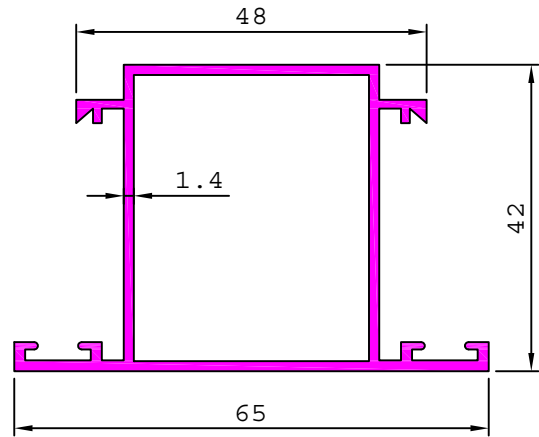

20765

0.710 kg/m

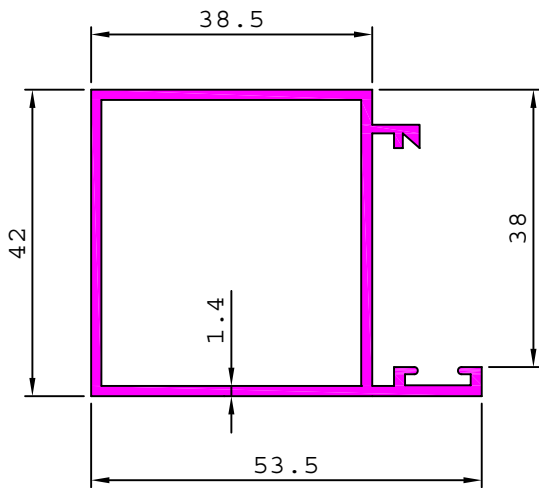

20863

0.497 kg/m

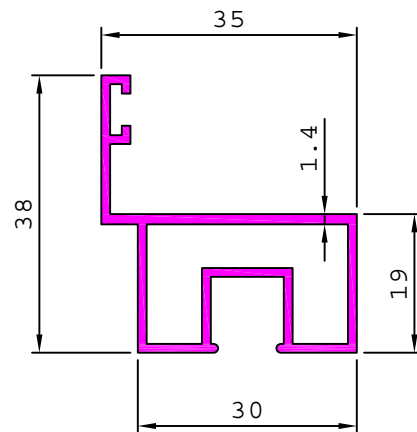

20864

0.371 Kg/m

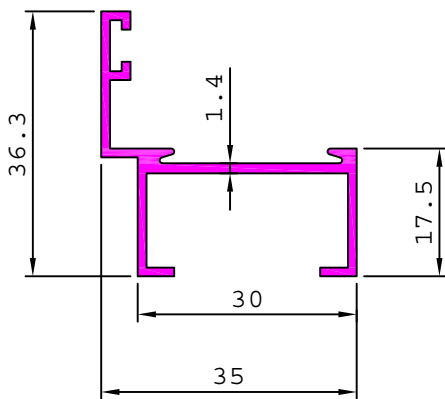

20865

0.598 Kg/m

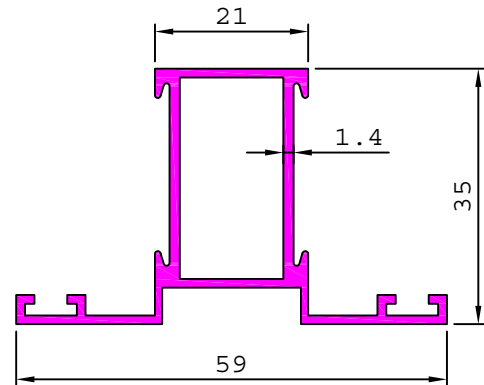

DETAILS OF CASEMENT WINDOW SECTIONS

20895

0.439 kg/m

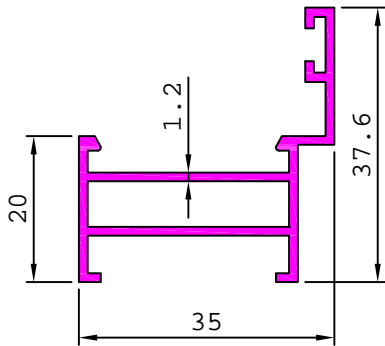

20896

0.565 kg/m

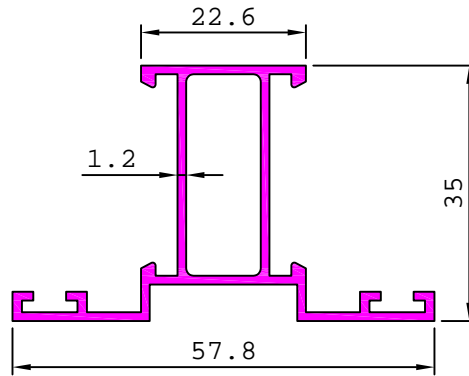

20897

0.496 kg/m

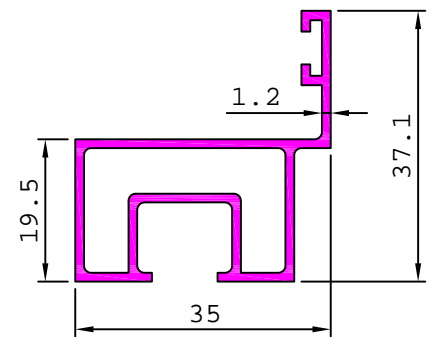

20899

0.715 kg/m

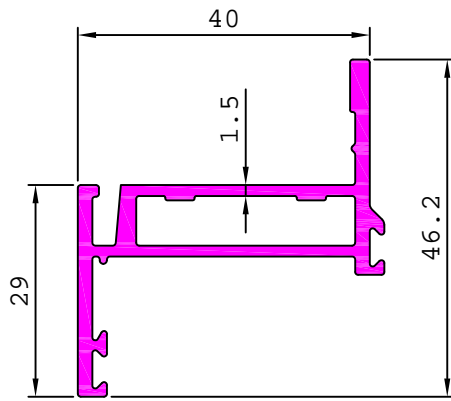

20902

1.386 kg/m

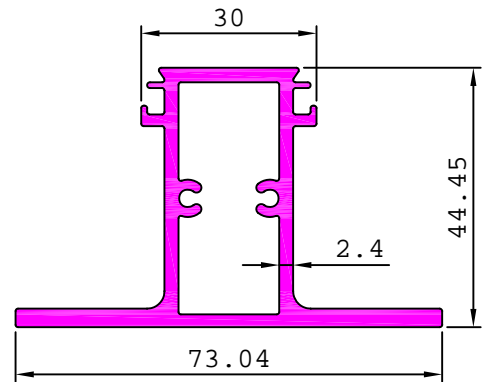

20900

1.207 kg/m

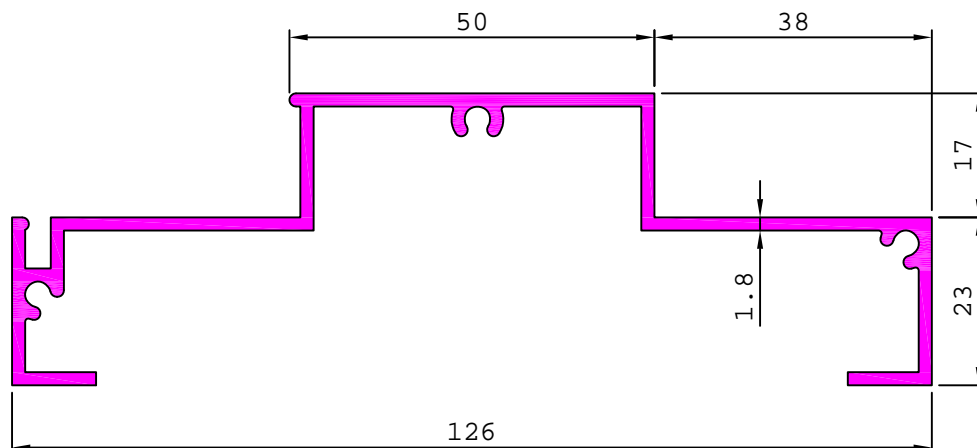

SUPER PROFILE

DETAILS OF CASEMENT WINDOW SECTIONS

20909

1.123 kg/m

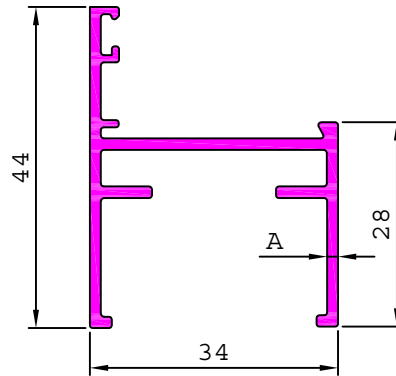
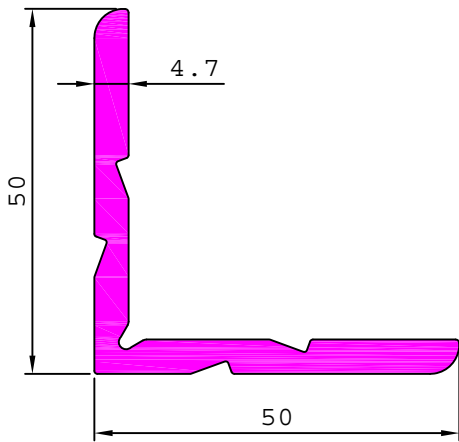

SL. No.	Section No.	A	Weight kg/m
1	21141	1.35	0.473
2	20913	1.50	0.527
3	21096	2.00	0.635

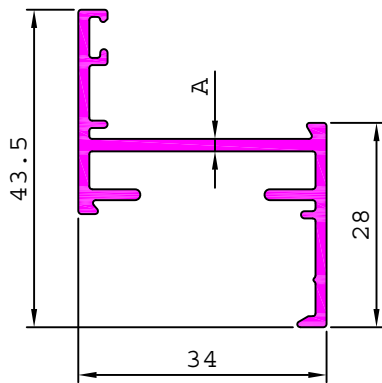

SL. No.	Section No.	A	Weight kg/m
1	21142	1.35	0.425
2	20914	1.50	0.473
3	21095	2.00	0.548

20916

0.877 kg/m

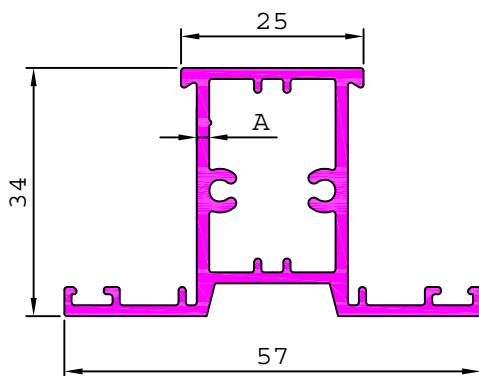
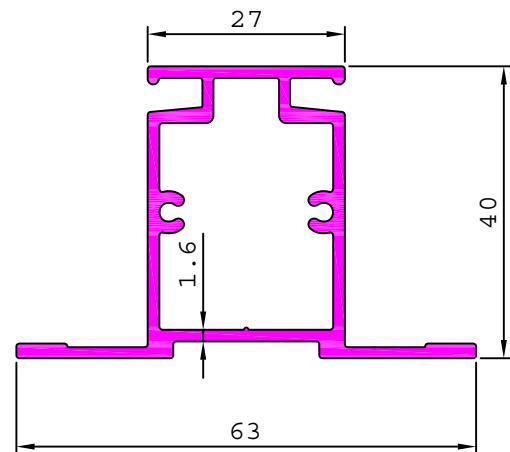

SL. No.	Section No.	A	Weight kg/m
1	21140	1.40	0.701
2	20915	1.70	0.766
3	21097	2.00	0.924

20918

0.606 kg/m

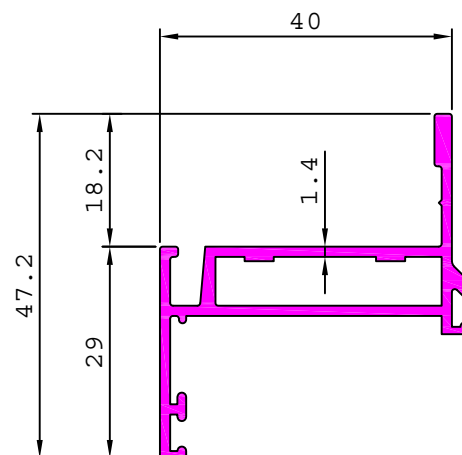

SUPER PROFILE

DETAILS OF CASEMENT WINDOW SECTIONS

20919

0.607 kg/m

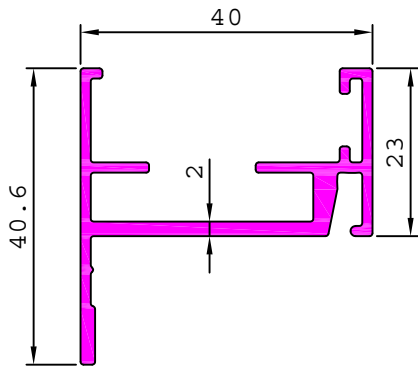

20927

1.202 kg/m

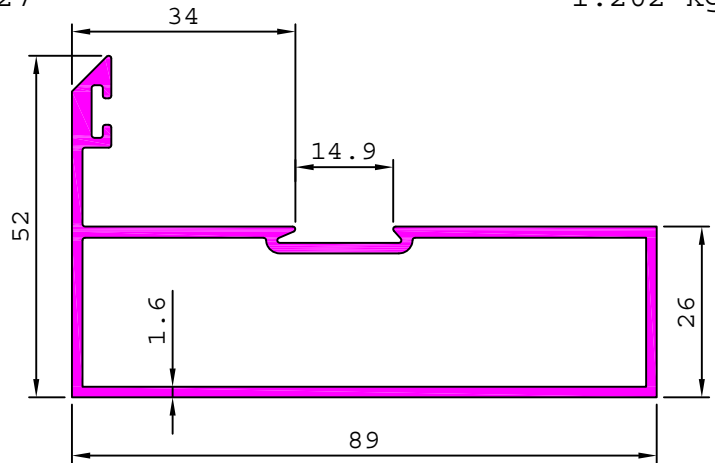

20930

0.701 kg/m

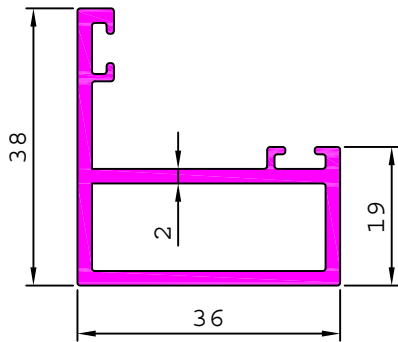

20935

0.476 kg/m

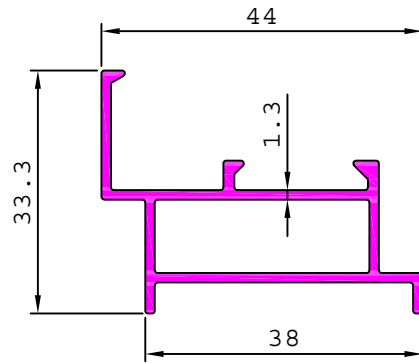

20989

0.918 kg/m

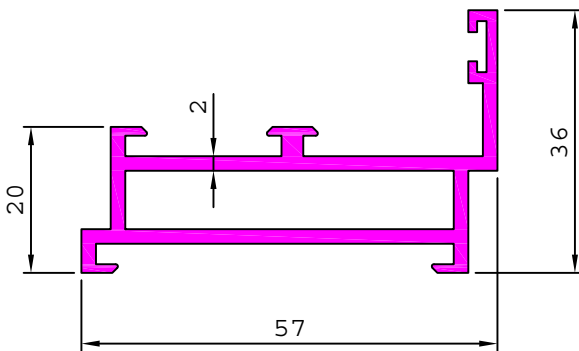

20990

0.670 kg/m

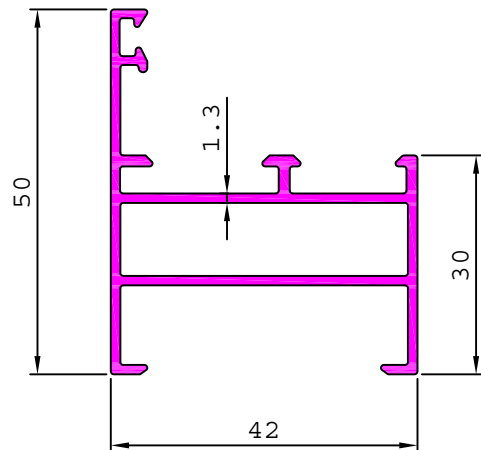

SUPER PROFILE

DETAILS OF CASEMENT WINDOW SECTIONS

20991 0.762 kg/m

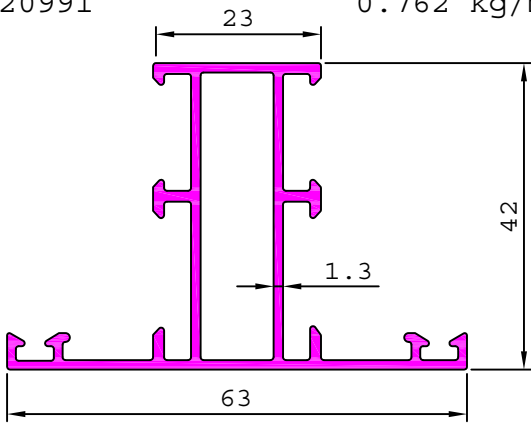

21015 0.472 kg/m

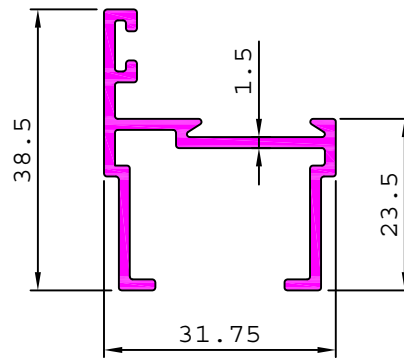

21016 0.239 kg/m

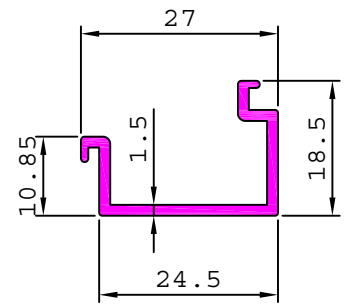

21038 1.059 kg/m

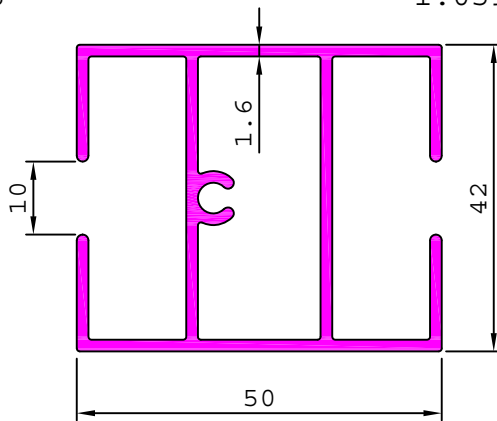

21039 1.018 kg/m

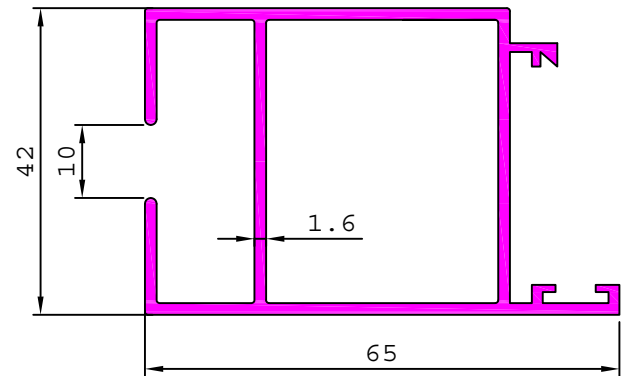

21044 0.363 kg/m

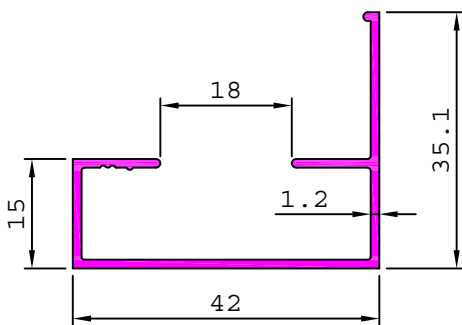

21050 1.088 kg/m

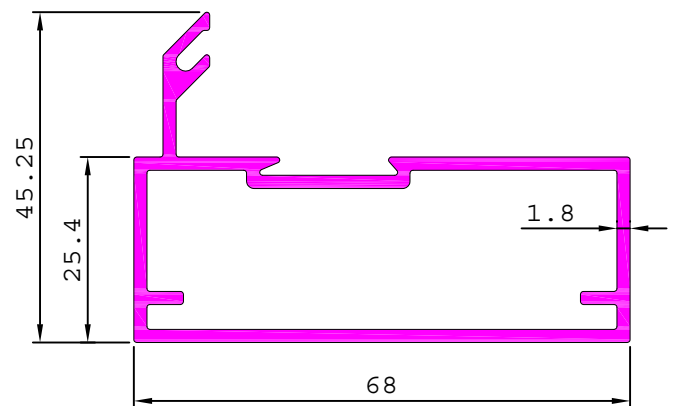

21057 0.559 kg/m

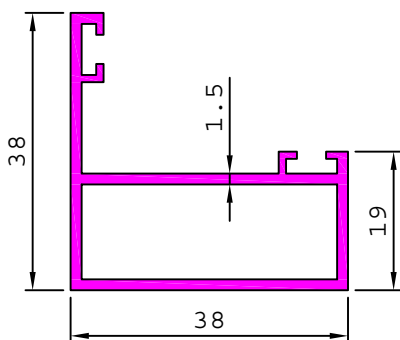

21062 0.843 kg/m

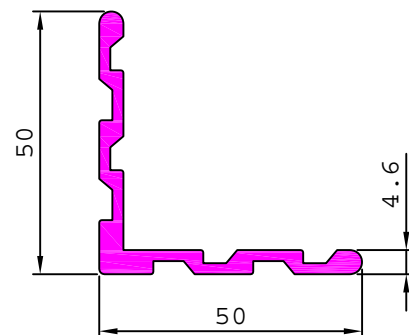

SUPER PROFILE

DETAILS OF CASEMENT WINDOW SECTIONS

21063 0.651 kg/m 21064 0.510 kg/m 21065 0.444 kg/m

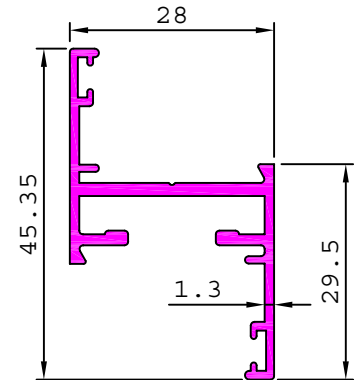
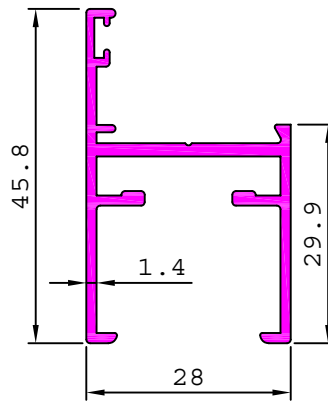
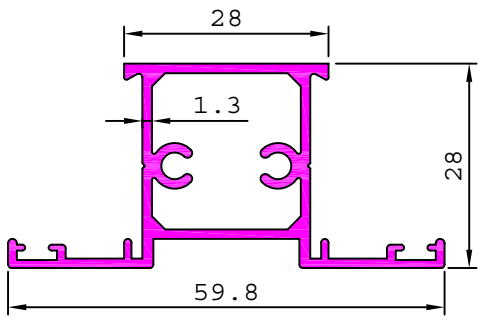

21080 0.747 kg/m 21086 0.613 kg/m

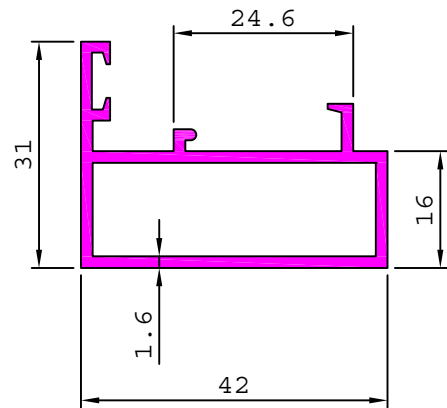
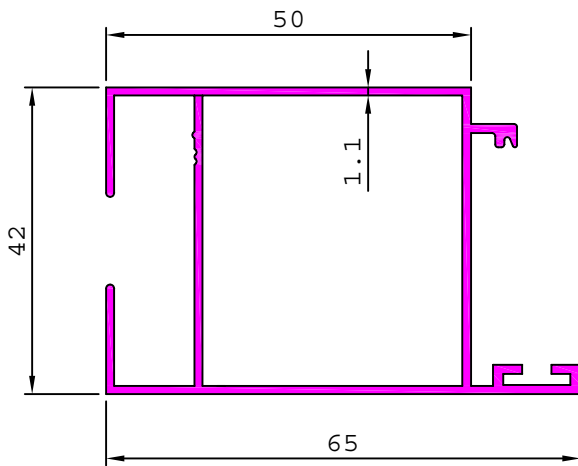

21104 0.748 kg/m 21105 0.940 kg/m

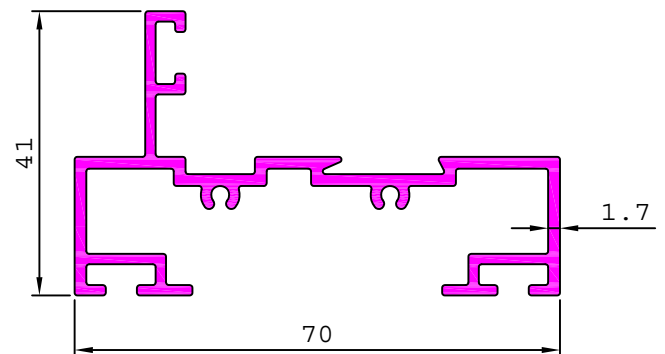
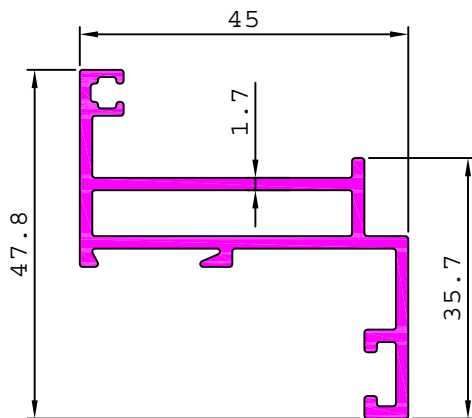

SUPER PROFILE

DETAILS OF CASEMENT WINDOW SECTIONS

211106

1.265 kg/m

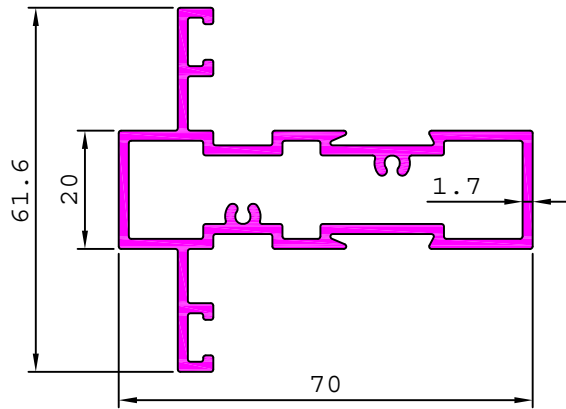

211119

1.426 kg/m

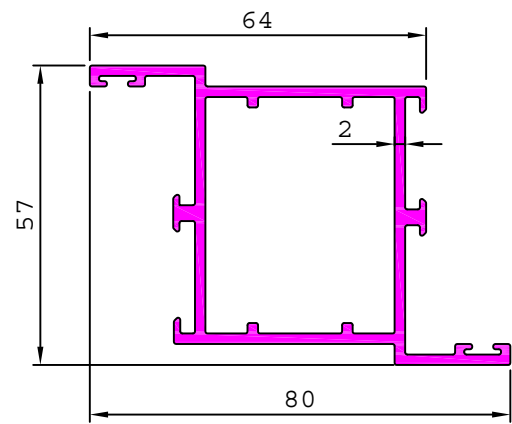

211160

0.833 kg/m

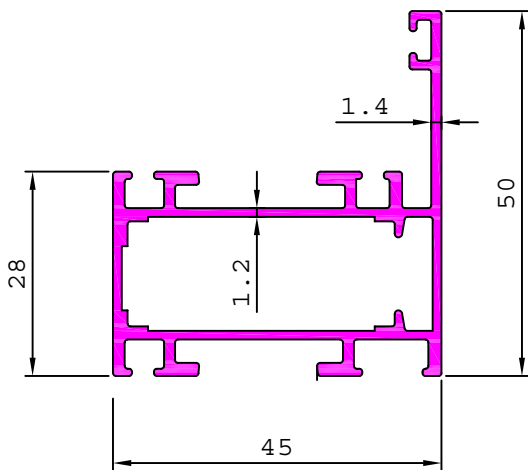

211161

1.083 kg/m

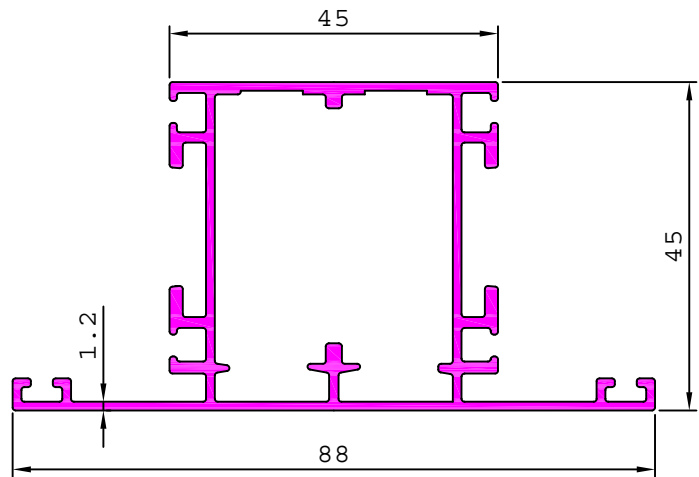

211177

0.579 kg/m

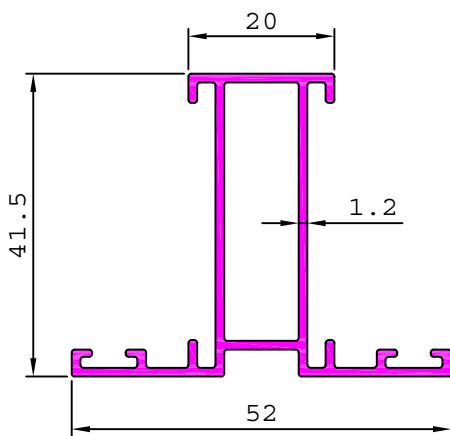

211178

0.637 kg/m

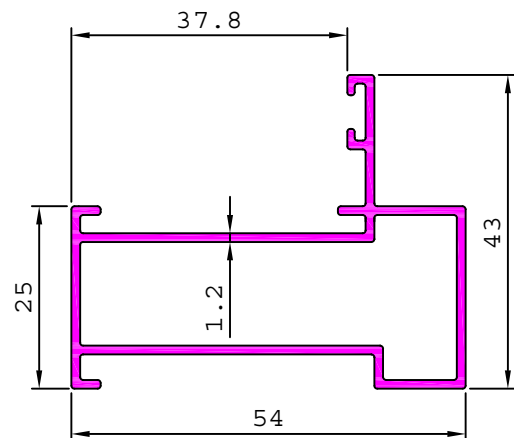

SUPER PROFILE

DETAILS OF CASEMENT WINDOW SECTIONS

21185

0.945 kg/m

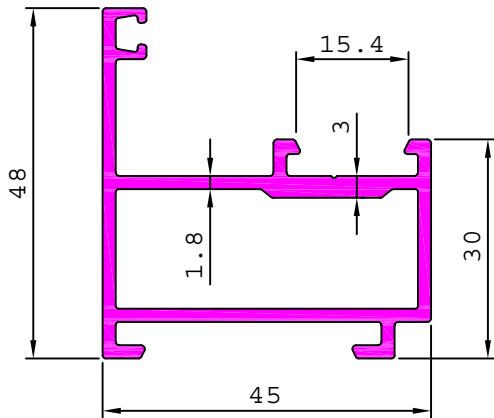

21186

1.223 kg/m

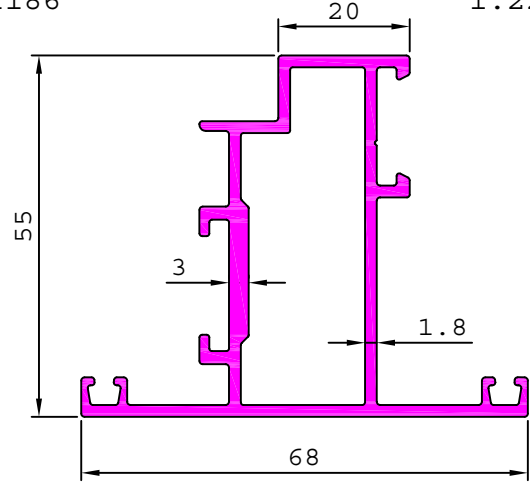

21187

1.208 kg/m

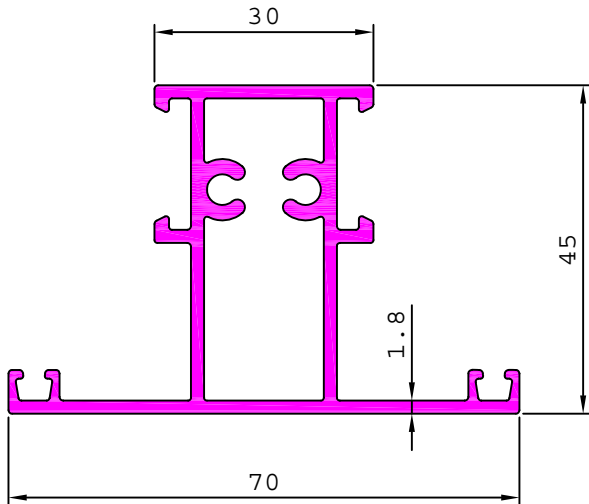

21214

0.930 kg/m

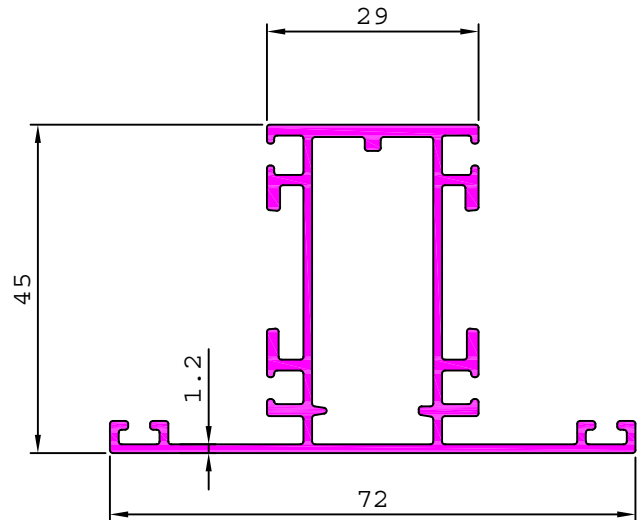

21215

0.959 kg/m

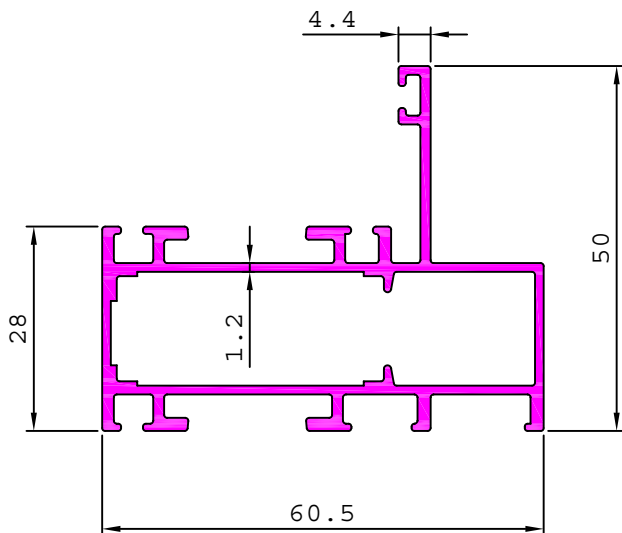

21226

1.418 kg/m

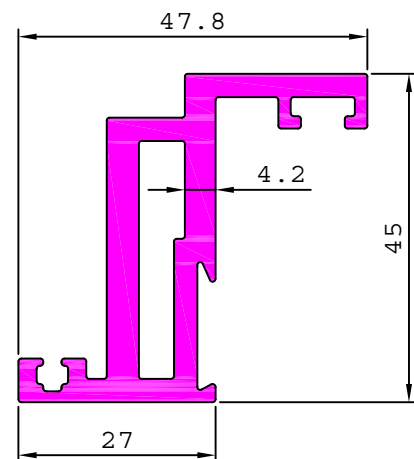

DETAILS OF CASEMENT WINDOW SECTIONS

21227 1.843 kg/m

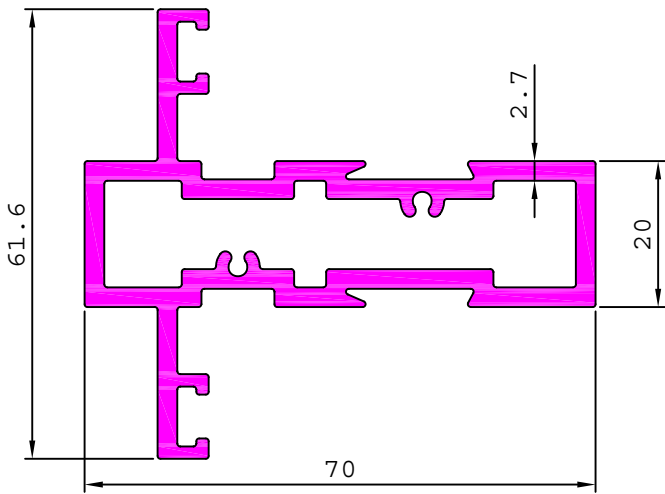

21228 1.445 kg/m

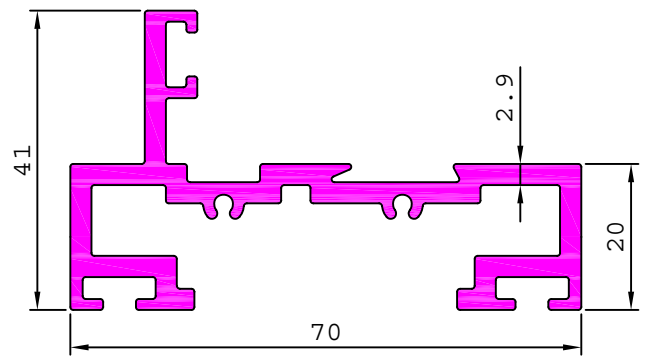

21230 0.820 kg/m

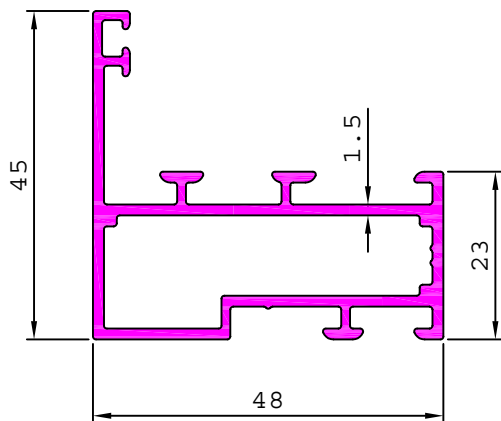

21231 0.382 kg/m

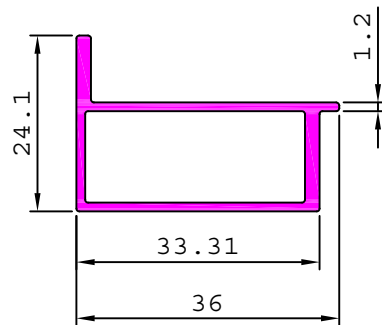

21234 1.689 kg/m

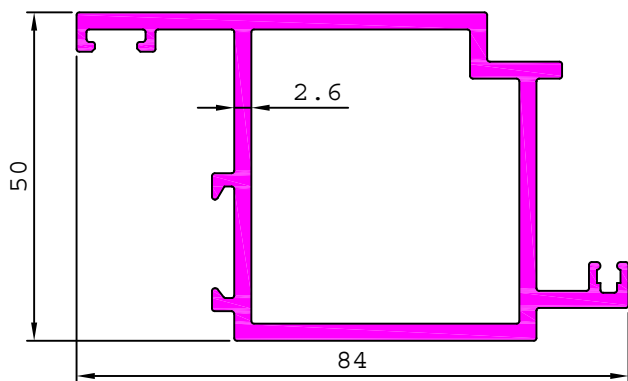

21235 1.867 kg/m

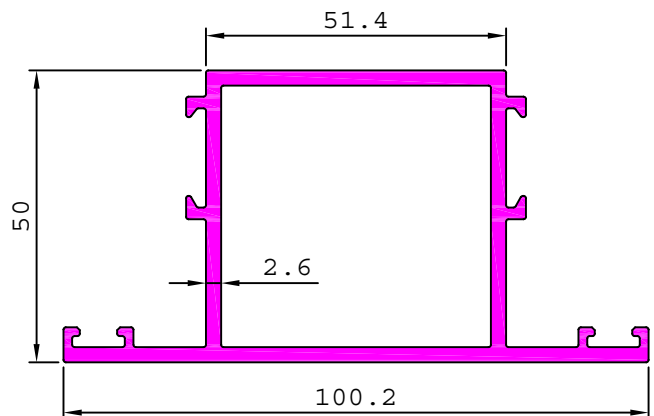

SUPER PROFILE

DETAILS OF CASEMENT WINDOW SECTIONS

21236

1.990 kg/m

21252

0.946 kg/m

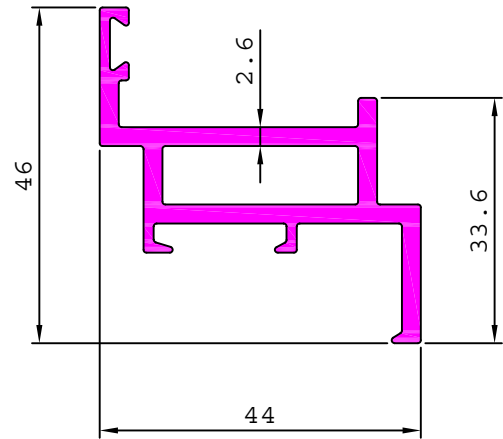
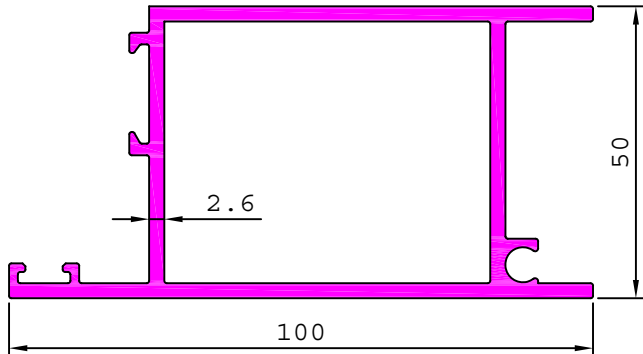

21274

1.873 kg/m

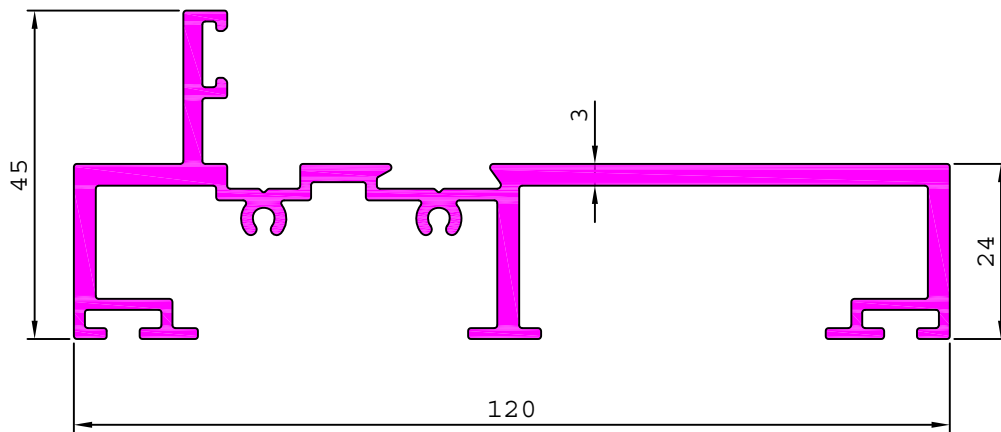

21279

2.182 kg/m

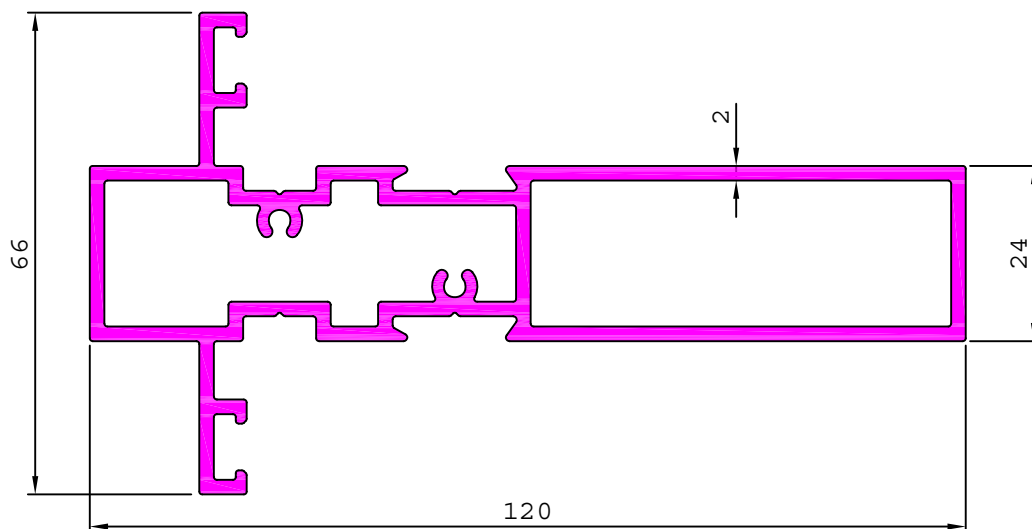

SUPER PROFILE

DETAILS OF CASEMENT WINDOW SECTIONS

21280

1.630 kg/m

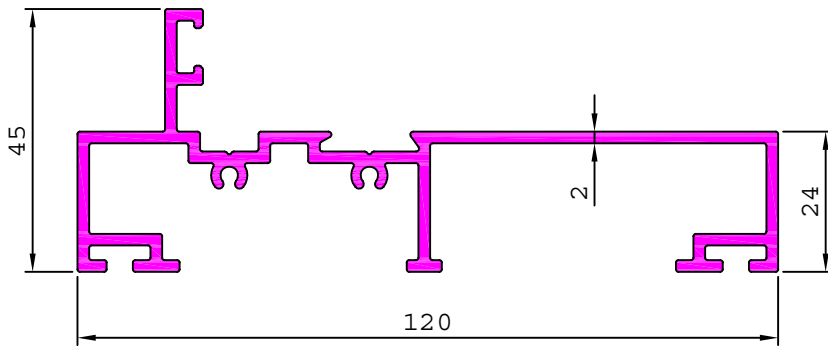

21284

0.767 kg/m

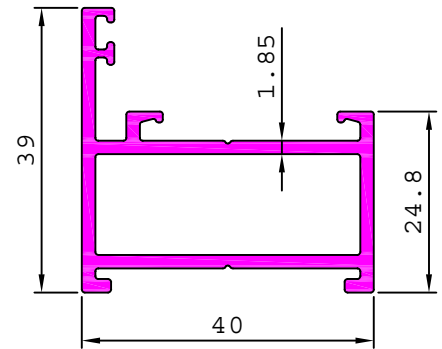

21290

1.049 kg/m

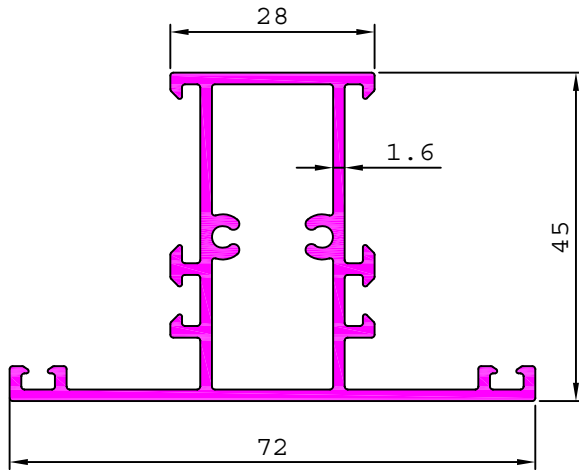

21292

0.860 kg/m

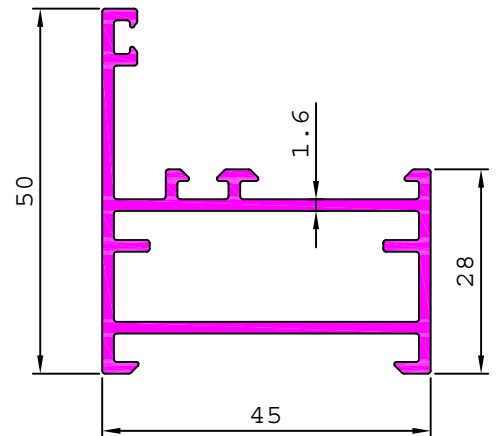

21291

1.121 kg/m

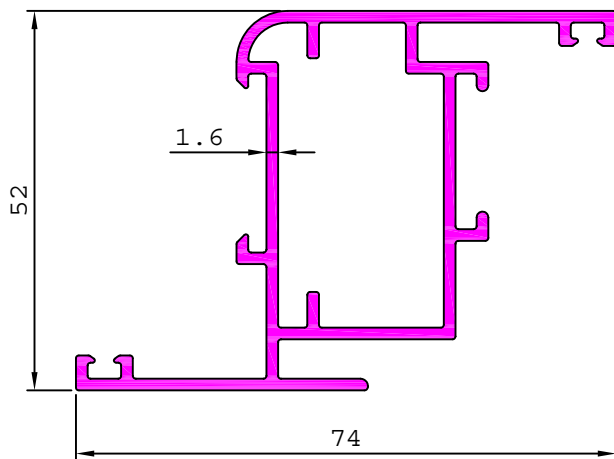

21293

1.251 kg/m

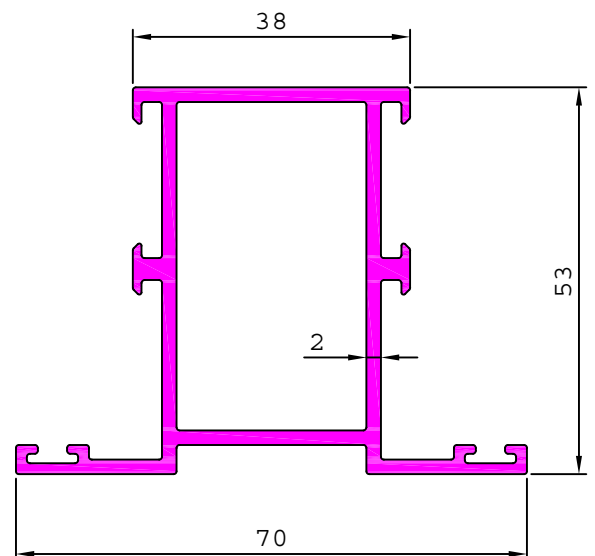

SUPER PROFILE

DETAILS OF CASEMENT WINDOW SECTIONS

21295

1.121 kg/m

21313

0.978 kg/m

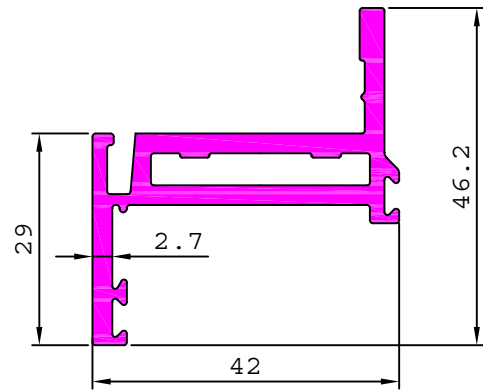
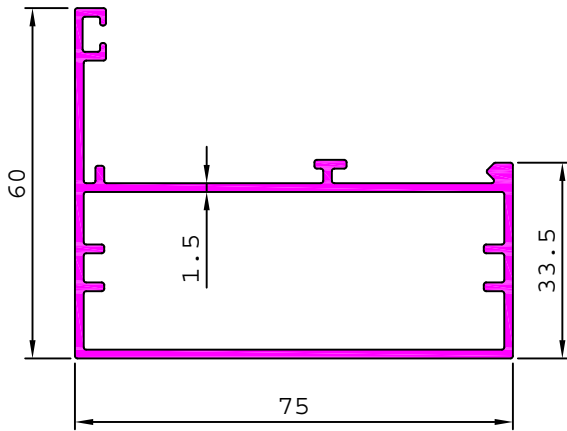

21311

3.524 kg/m

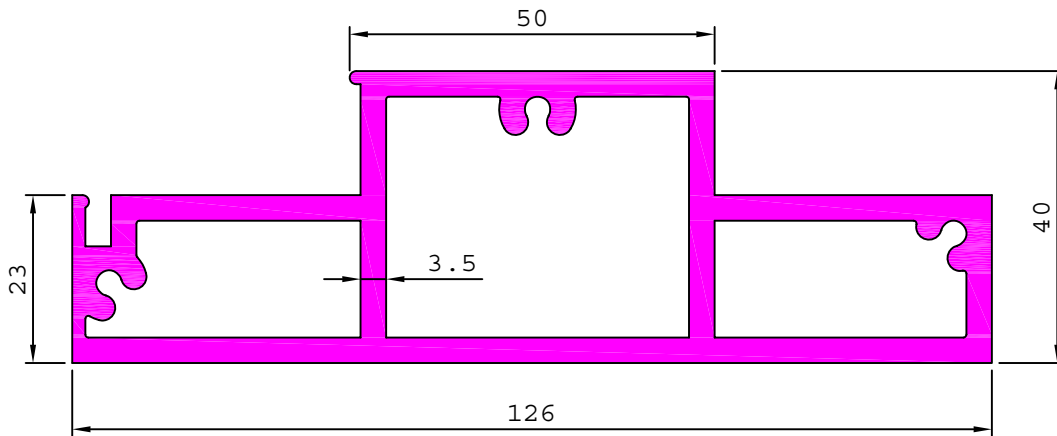

21312

4.033 kg/m

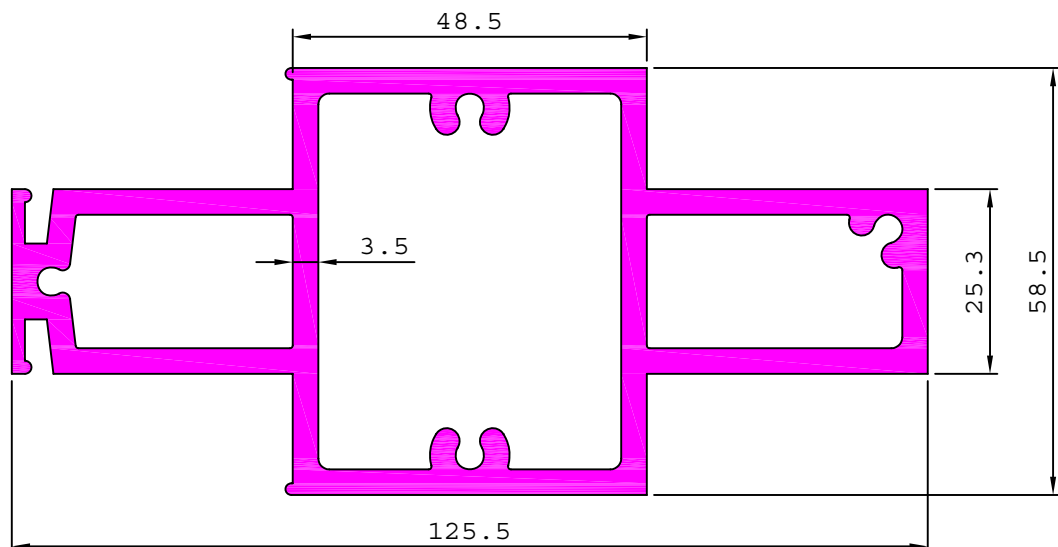

DETAILS OF CASEMENT WINDOW SECTIONS

21314 0.834 kg/m

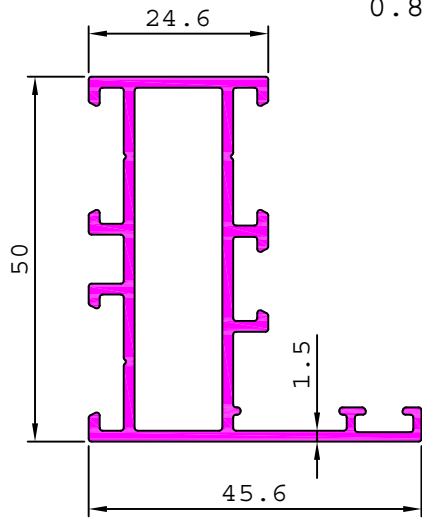

21322 0.860 kg/m

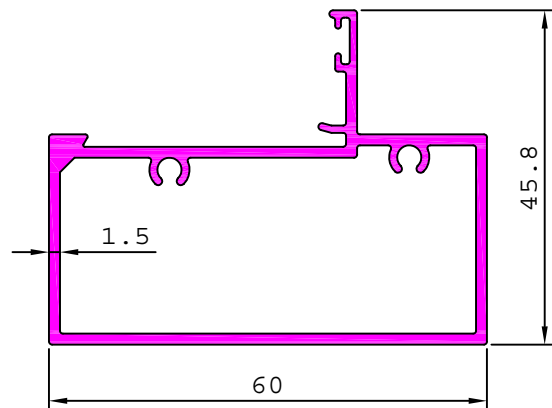

21323 0.976 kg/m

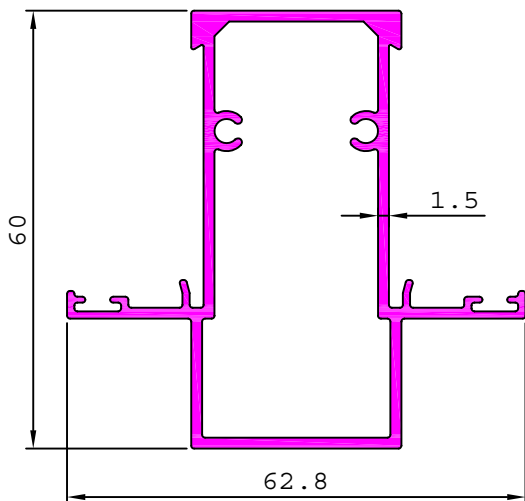

21324 0.573 kg/m

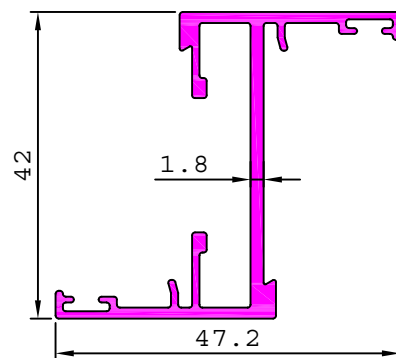

S2210 0.946 kg/m

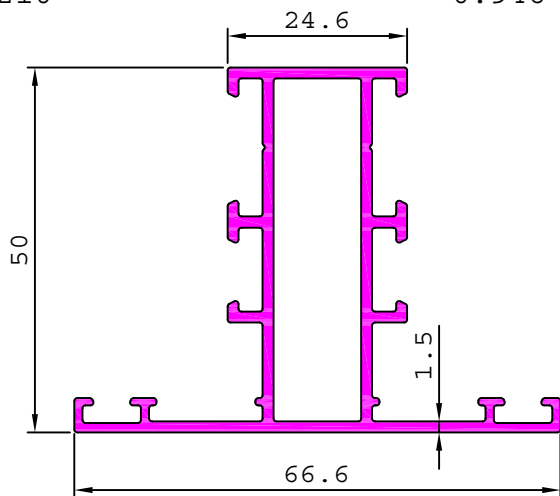

S2211 0.940 kg/m

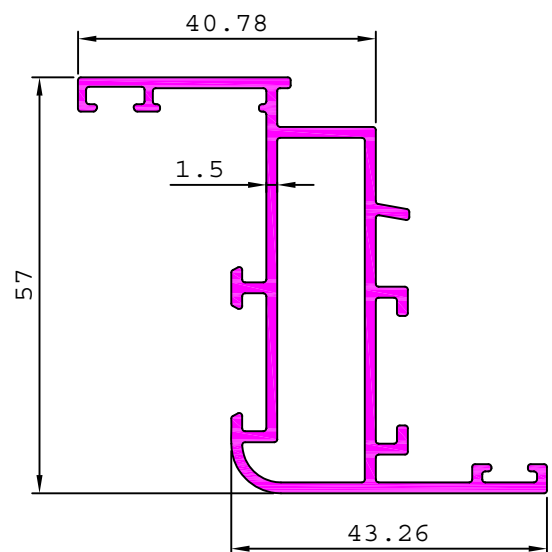

CASEMENT WINDOW

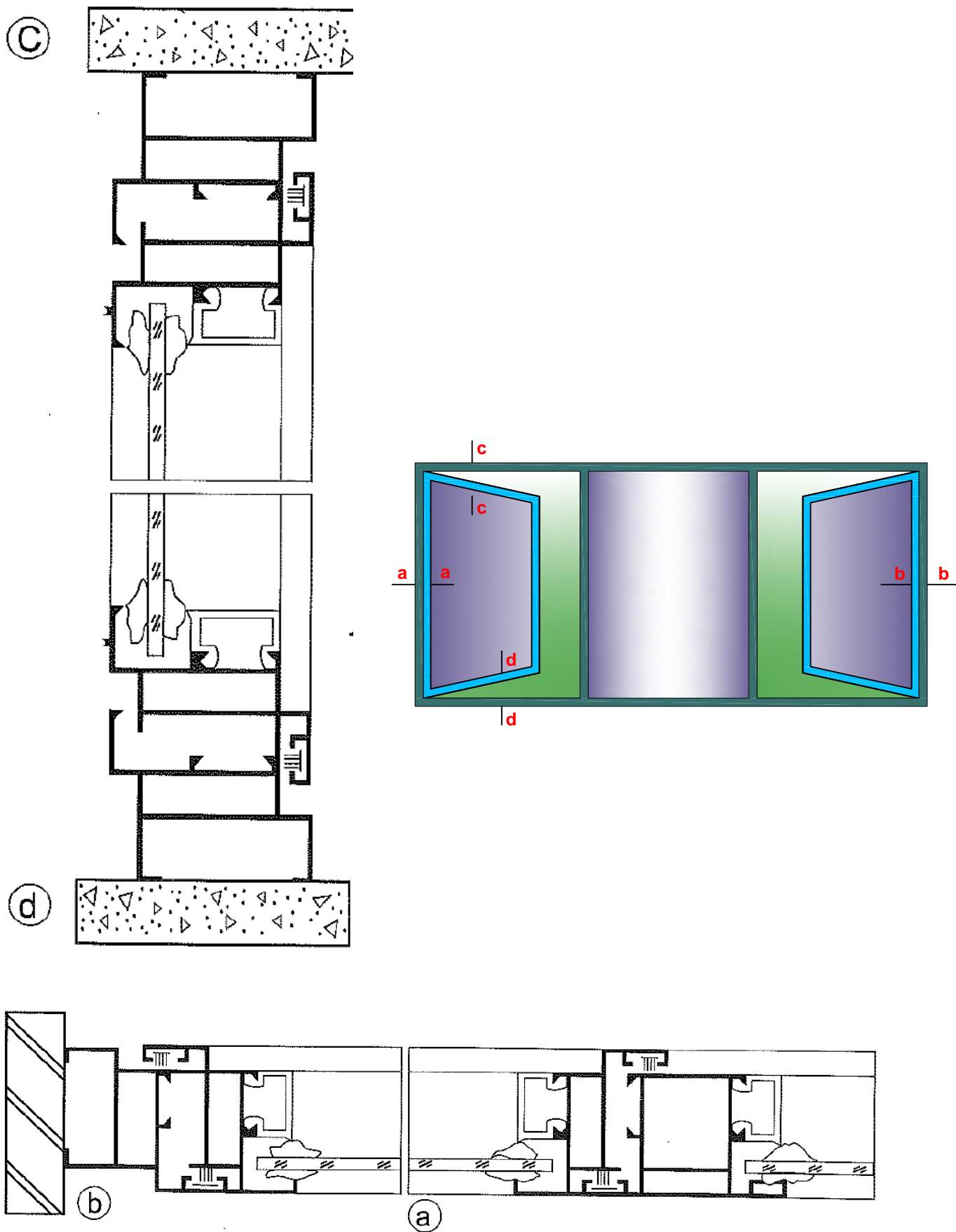

SUPER PROFILE

DETAILS OF CASEMENT WINDOW SECTIONS

SERIES - A

20628 0.714 kg/m

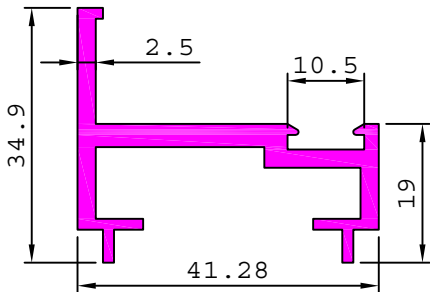

19359 0.301 kg/m

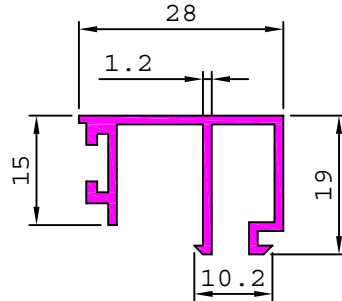

20629 0.711 kg/m

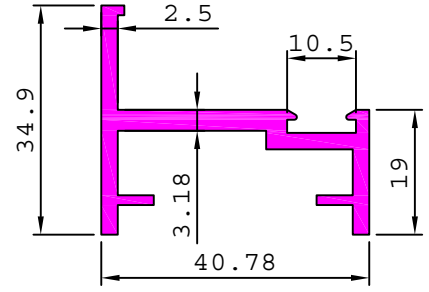

20630 0.892 kg/m

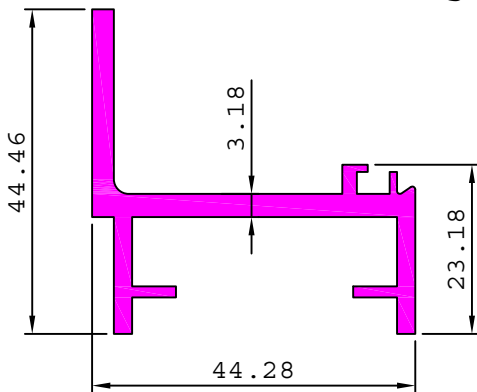

20641 1.072 kg/m

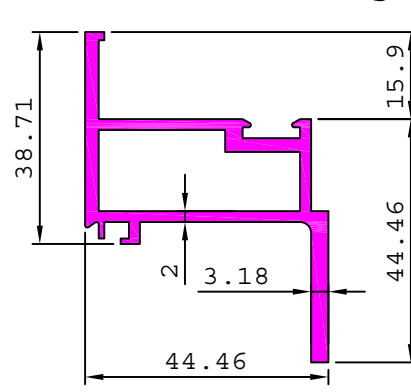

20727 1.053 kg/m

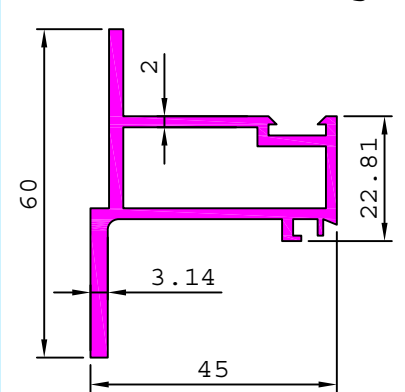

SERIES - B

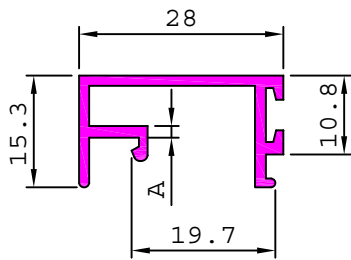

SL. No.	Section No.	A	Weight kg/m
1	19392	1.11	0.224
2	19391	1.50	0.289

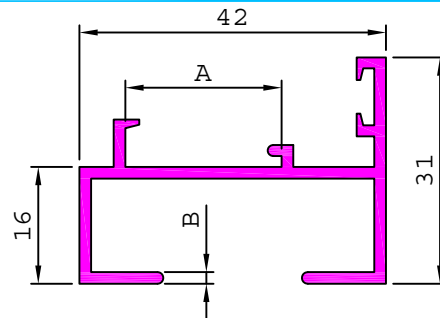

SL. No.	Section No.	A	B	Weight kg/m
1	20942	22.10	1.25	0.434
2	20558	21.40	1.60	0.534

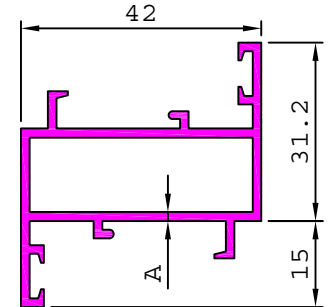

SL. No.	Section No.	A	Weight kg/m
1	20943	1.35	0.651
2	20559	1.50	0.724

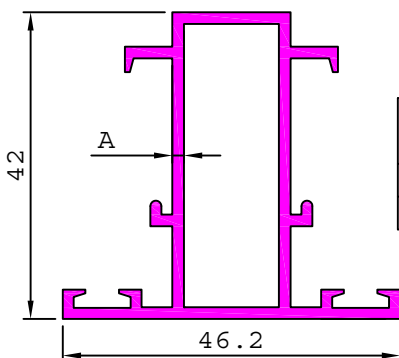

SL. No.	Section No.	A	Weight kg/m
1	20944	1.35	0.651
2	20560	1.60	0.764

DETAILS OF CASEMENT WINDOW SECTIONS

SERIES - C

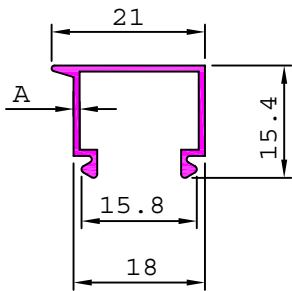

SL. No.	Section No.	A	Weight kg/m
1	19362	0.60	0.108
2	19369	0.85	0.137

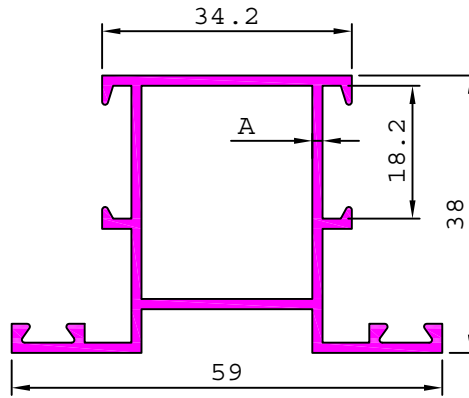

SL. No.	Section No.	A	Weight kg/m
1	20720	1.40	0.729
2	21285	1.60	0.807

20719

0.575 kg/m

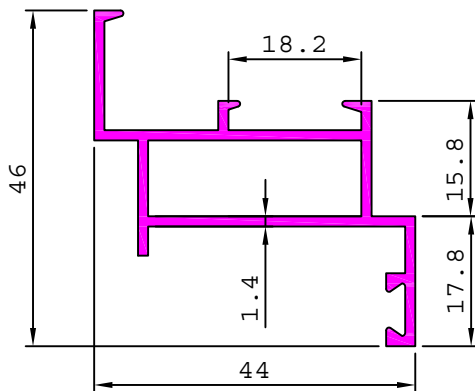

20721

0.622 kg/m

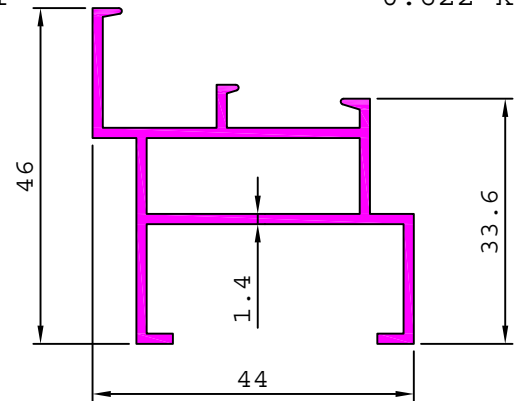

20903

0.522 kg/m

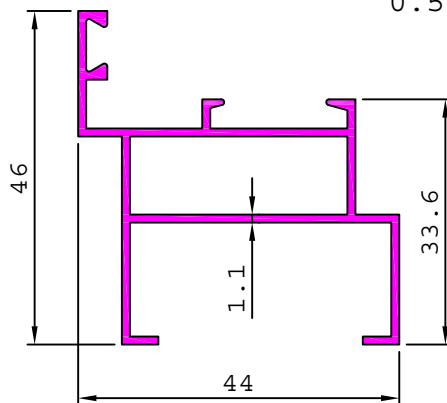

21286

0.649 kg/m

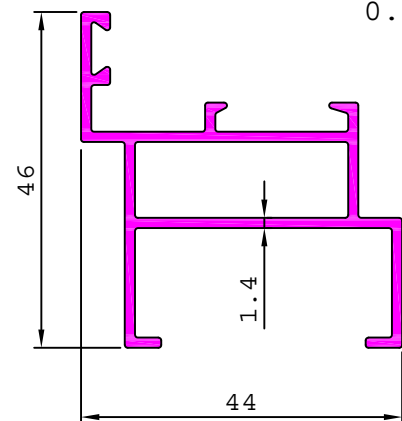

DETAILS OF CASEMENT WINDOW SECTIONS

SERIES - D

20824 0.870 kg/m

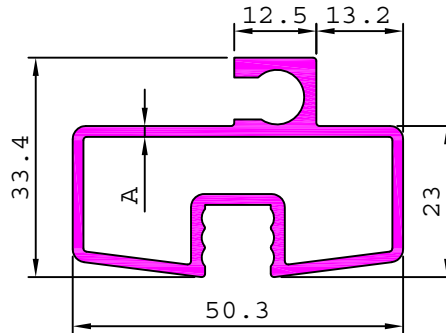
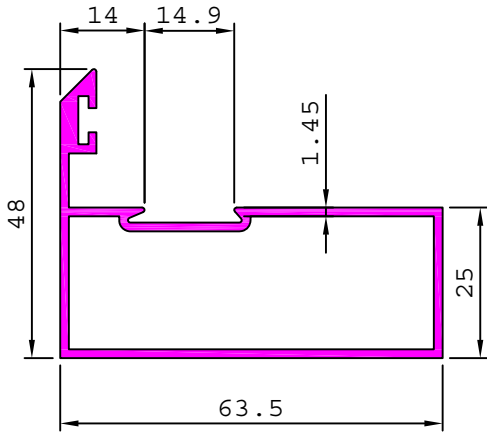

SL. No.	Section No.	A	Weight kg/m
1	20825	1.64	0.854
2	20642	2.00	0.997

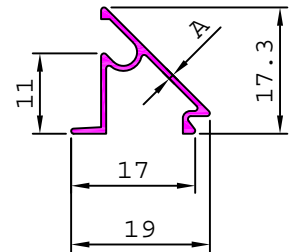

SL. No.	Section No.	A	Weight kg/m
1	19352	0.70	0.097
2	19370	0.80	0.109
3	19360	0.90	0.124

21310 1.071 kg/m

